

T H E R M O M E T R I C S
A C O M M I T M E N T T O E X C E L L E N C E

Type S/AS/ES

Thermometrics

Precision, Ultrastable

NTC Temperature

Standards



The Type S/AS/ES Thermometrics temperature standards consist of ultra-stable thermistor probes assembled into thin wall stainless steel housings with shielded extension leads. The thermistors used receive special processing to ensure long term stability. All thermistor temperature standards are ruggedly constructed and are suitable for liquid immersion.

Applications

Thermometrics Temperature Standards are rugged, precision sensors suitable for use as secondary or working temperature standards for all laboratory metrology applications. They generally are not affected by shock and vibration and, consequently, are also suitable for field use. Our temperature standards fill the need for low cost temperature standards for general laboratory and hospital use, clinical applications and process temperature measurements. Special versions are available for military and space use. Standards are also available for other temperature ranges in a variety of sizes and enclosures.

Amphenol
Advanced Sensors

Configuration

Temperature standards are enclosed in thin-wall stainless tubes, welded closed at one end. The shielded cable is encapsulated into the tube to provide a solid moisture-proof seal. Full immersion of the metal portion of the standard is permissible. The calibration data is given for an immersion depth of 8" on 9" housings, and 4" on 4 1/2" long housings.

Temperature Range

The Type "S" and Type "AS" are designed for operation over the range of 0°C to 60°C. The Type "ES" is rated for 0°C to 100°C.

Stability

The stability of each temperature standard is guaranteed for a period of one year. When properly used, the following stability ratings apply:

Type "AS" 0.002° C/year

Type "S" 0.005° C/year

Type "ES" 0.005° C/year

Calibration

Precision calibration, traceable to the National Institute of Standards and Technology, is provided for all temperature standards. A computer generated table in increments of 0.01°C is furnished with each calibration based on the interpolation formula, $RT = \exp(A_0 + A_1/T + A_2/T^2 + A_3/T^3)$. The constants for the formula are obtained from a polynomial regression performed on the calibration data obtained. Over the range of 0°C to 60°C, calibration is performed at the triple point of water (0.01°C) and 15°C, 25°C, 30°C, 37°C, 50°C, and 60°C. For the range of 0°C to 100°C, calibrations are performed at the triple point of water, 25°C, 30°C, 37°C, 60°C, 80°C, and 100°C. Two-wire calibrations are performed using a wheatstone Bridge calibrated to an accuracy of better than 0.005%. Four-wire calibrations are based on a comparison technique using a ratio bridge having an accuracy of 0.0002%. All resistance measurements are referenced to standard resistors calibrated by NIST. All temperature measurements are made using a standard platinum resistance thermometer which has been calibrated by NIST.

Resistance Vs. Temperature Characteristic

The nominal resistance values are shown below:

Type	Resistance In Ohms			
	0°C	25°C	60°C	100°C
"AS" & "S"	14250	5000	1458	-
"AS" & "S"	11400	4000	1166	-
"ES"	28500	10000	2915	925

Read-Out Devices

Thermometrics' Temperature Standards are designed for use with any suitable resistance measuring instrument. Care must be taken, however, to avoid excessive self-heating of the thermistor. A power dissipation of 4 microwatts will result in 0.001°C self-heat. Self-heat error can be minimized by duplicating the conditions of calibration which are provided with each certificate of calibration.

Available Models

Three different types are available, each in four different sizes, to accommodate all standard requirements:

TYPE "S", which includes S10, S15, S20, S25, offer standard 0.005°C/year stability and temperature range 0° to 60° C.

TYPE "AS", which includes AS110, AS115, AS120, AS125, offer 0.002°C/yr stability and temperature range 0° to 60° C.

TYPE "ES", which includes ES210, ES215, ES220, ES225 offer 0.005° C/yr stability and temperature range 0° to 100°C.

Coding

All temperature standards Type "S", "AS", & "ES" may be ordered by part number and are available in two-wire and four-wire terminations. Unless otherwise specified, a two-wire termination will be supplied. If a four-wire termination is desired, specify by adding the suffix "4wire". Therefore an ES220 unit in 4-wire is ordered as "ES220-4 wire".

Type	Accuracy	
	0°C - 60°C	60°C - 100°C
"AS"	0.001°C	-
"S"	0.0015°C	-
"ES"	0.0015°C	0.0025°C

The uncertainties of the computer tables are 0.001°C for the Type "AS" and 0.003°C for the Types "S" and "ES".

Dimensions In Inches ("L") Dia X ("D") Long	Standard Type "S"	Stability °C/Year	Absolute Type "AS"	Stability °C/Year	Temp. Range for "S" and "AS" °C	Extended Temp. Range Type "ES"	Stability °/Year °C	Temp. Range "ES" °C
1/4" X 9"	S10	0.005	AS110	0.002	0-60	ES210	0.005	0-100
1/8" X 4-1/2"	S15	0.005	AS115	0.002	0-60	ES215	0.005	0-100
1/4" X 4-1/2"	S20	0.005	AS120	0.002	0-60	ES220	0.005	0-100
1/8" X 9"	S25	0.005	AS125	0.002	0-60	ES225	0.005	0-100

Standard Configuration

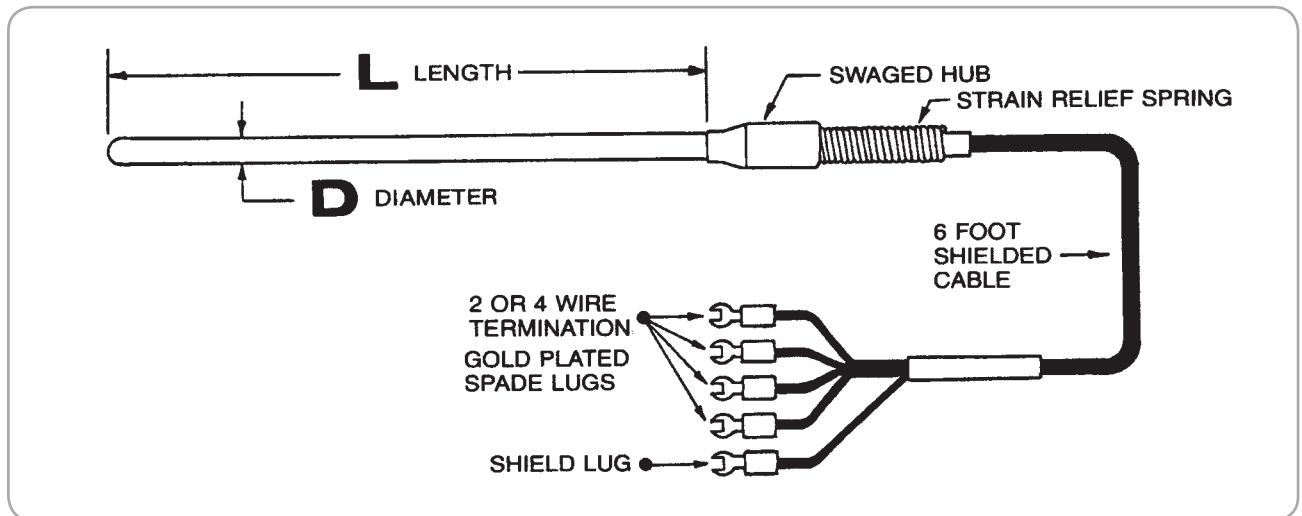

Amphenol

Advanced Sensors

www.amphenol-sensors.com

© 2014 Amphenol Corporation. All Rights Reserved. Specifications are subject to change without notice. Other company names and product names used in this document are the registered trademarks or trademarks of their respective owners.