

# FLEXIBLE POWER SYSTEMS

## FEATURES & BENEFITS

- Board-to-board and discrete wire cable systems
- Power Mate® system with polarized guide posts
- Mini Mate® system with reliable Tiger Buy™ contacts
- Individually shrouded contacts
- Elevated stack heights
- Optional polarization
- Vertical and right-angle for parallel, perpendicular and coplanar applications
- Rugged metal or plastic latching systems
- Cable components and tooling available

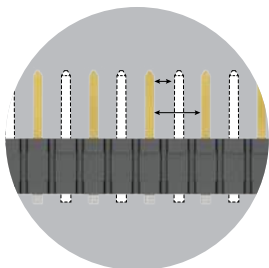

Selectively loading contacts achieves customer specific creepage and clearance requirements.

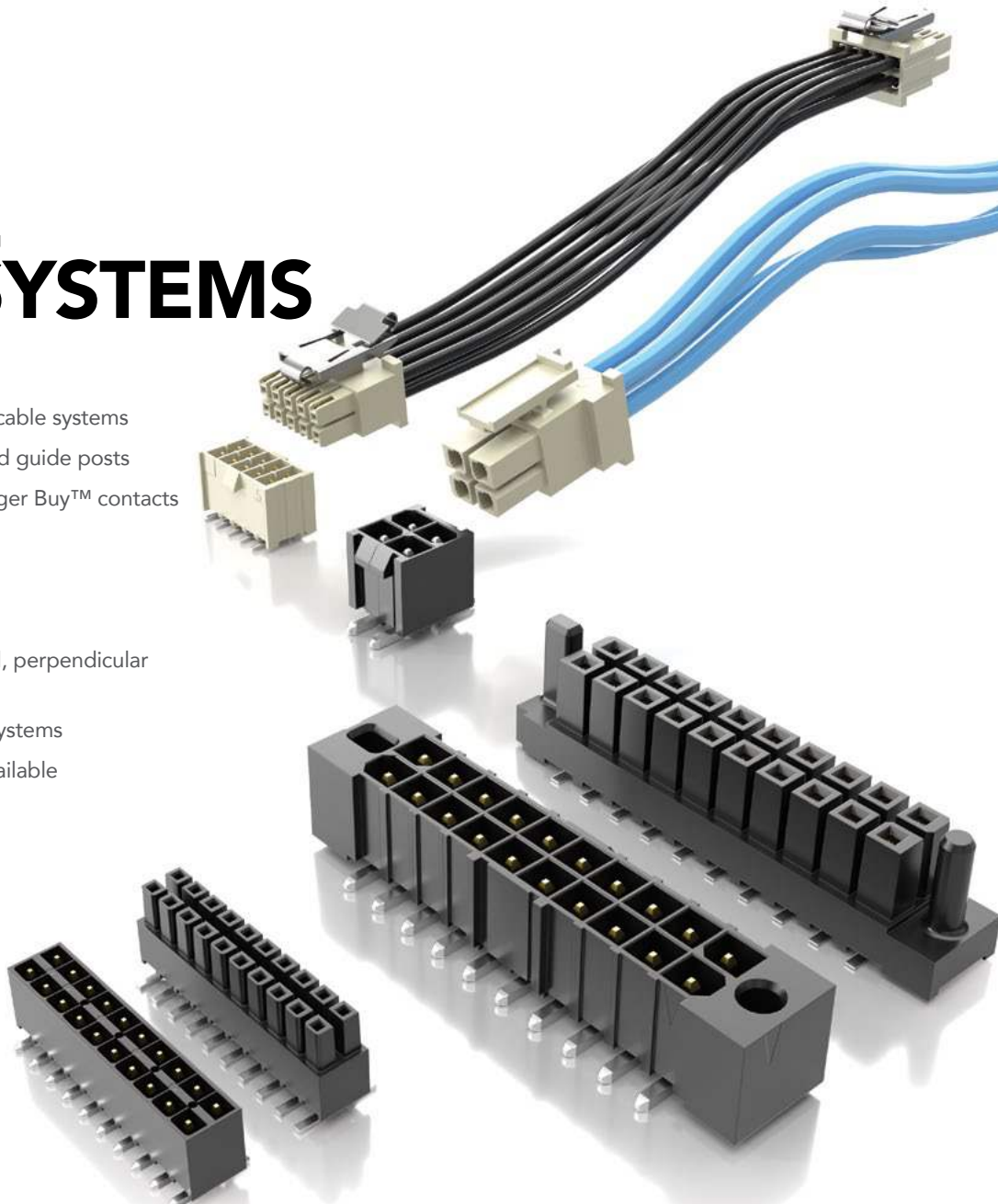

## KEY SPECIFICATIONS

SERIES	IPT1/IP51	IPBT/IPBS	HPM/HPW/HPF	FWJ/HFWJ/FHP
PITCH	(2.54 mm) .100"	(4.19 mm) .165"	(5.08 mm) .200"	(3.96 mm) .156"
CCC (1 PIN)*	5.9 A	10.3 A /pin (2 pins powered)	16.6 A	13.1 A
CCC (2 PINS)*	4.8 A	8.4 A/pin (4 pins powered)	14.4 A	11.2 A
CCC (3 PINS)*	4.1 A	7.6 A/pin (6 pins powered)	13.2 A	10.3 A
CREEPAGE	(2.54 mm) .100"	(4.27 mm) .168"	(3.94 mm) .155"	(3.92 mm) .154"
CLEARANCE	(1.91 mm) .075"	(3.05 mm) .120"	(3.94 mm) .155"	(2.82 mm) .111"
VAC	775	400	850	600
VDC	1095	565	1200	845
CYCLES	1000 (MFG Tested)	100	100	100

## (2.54 mm) .100" PITCH • SHROUDED POWER CONNECTOR SET

IPT1	1	NO. PINS PER ROW	LEAD STYLE	PLATING OPTION	D	TAIL OPTION	OTHER OPTIONS
		05 10 15 20 25 (Standard Sizes)	Specify LEAD STYLE from chart	-L = 10 μ" (0.25 μm) Gold on contact, Matte Tin on tail		Requires -01 Lead Style (Leave blank for Through-hole)  -RA = Right-angle  -VS = Surface Mount	-A = Alignment Pin (-VS only) (N/A with -LC)  -LC = Locking Clip (Manual placement required) (-VS only) (N/A with -A)  -K = (6.00 mm) .236" DIA Polyimide film Pick & Place Pad (-VS only)  -TR = Tape & Reel (-VS only)  -FR = Full Reel Tape & Reel (must order max. quantity per reel; contact Samtec for quantity breaks) (-VS only)

**IPT1**  
Board Mates:  
IPS1

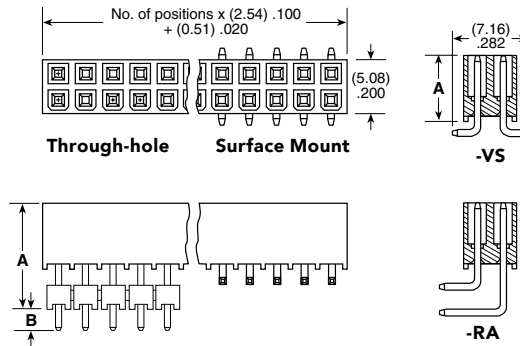

LEAD STYLE	MATED HEIGHT	A	B
-01	(11.05) .435	(6.35) .250	(2.16) .085
-01-VS	(13.59) .535	(6.35) .250	N/A
-02	(14.00) .551	(9.30) .366	(2.64) .104
-03	(16.00) .630	(11.30) .445	(2.16) .085
-04	(17.00) .669	(12.30) .484	(2.69) .106
-05	(19.00) .748	(14.30) .563	(2.46) .097
-06	(20.00) .787	(15.30) .602	(2.35) .093
-07	(25.00) .984	(20.30) .799	(2.31) .091
-08	(30.00) 1.181	(25.30) .996	(2.39) .094
-09	(35.00) 1.378	(30.30) 1.193	(2.46) .097

IPS1	1	NO. PINS PER ROW	01	PLATING OPTION	D	TAIL OPTION	OTHER OPTIONS
		05 10 15 20 25 (Standard Sizes)		-L = 10 μ" (0.25 μm) Gold on contact, Matte Tin on tail		Leave blank for Through-hole  -RA = Right-angle  -VS = Surface Mount	-LC = Locking Clip (Manual placement required) (-VS only)  -K = (5.50 mm) .217" DIA Polyimide film Pick & Place Pad (-VS only)  -TR = Tape & Reel (-VS only)  -FR = Full Reel Tape & Reel (must order max. quantity per reel; contact Samtec for quantity breaks) (-VS only)

**IPS1**  
Board Mates:  
IPT1

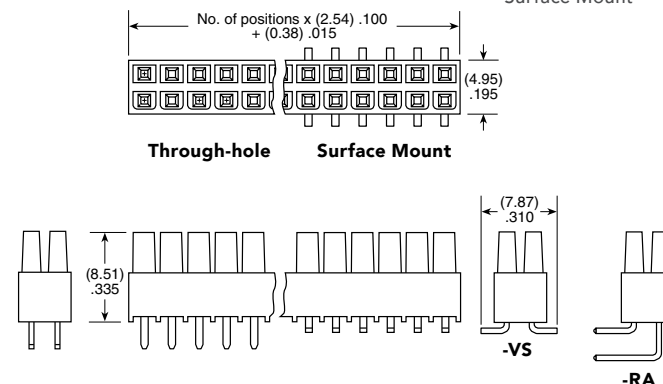
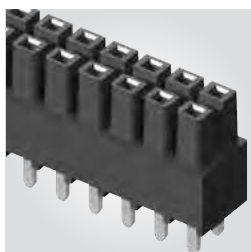

**Note:**  
Some lengths, styles and options are non-standard, non-returnable.

View complete specifications at: [samtec.com?IPT1](http://samtec.com?IPT1) & [samtec.com?IPS1](http://samtec.com?IPS1)