

THIS DRAWING IS UNPUBLISHED. RELEASED FOR PUBLICATION
 © COPYRIGHT - By - TE CONNECTIVITY ALL RIGHTS RESERVED.

REVISIONS				
P	LTR	DESCRIPTION	DATE	APVD
E1		NEW ADD PN ECO-17-004477	31-Mar-17	WQ.Y HL.C
E2		NEW ADD PN ECO-19-017316	13-Nov-19	WQ.Y K.T

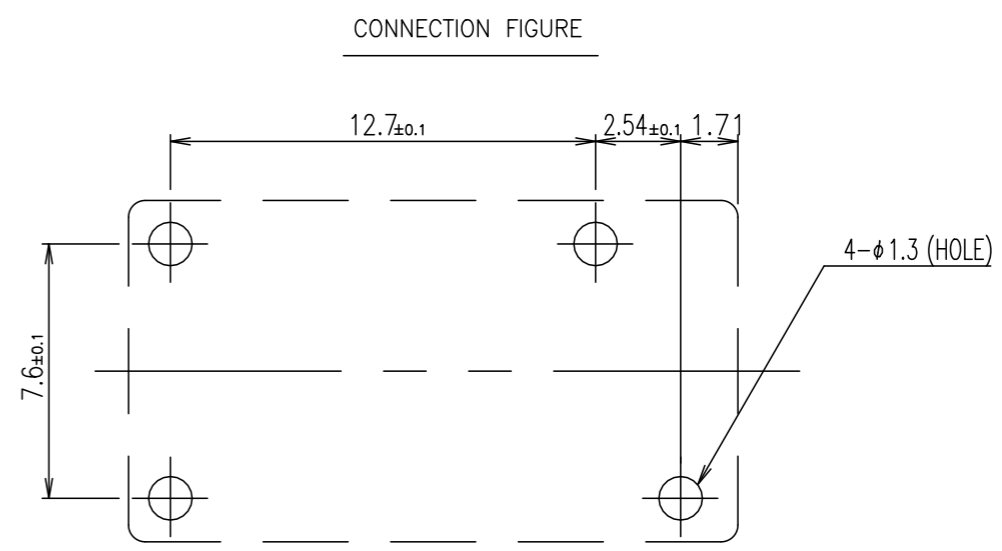
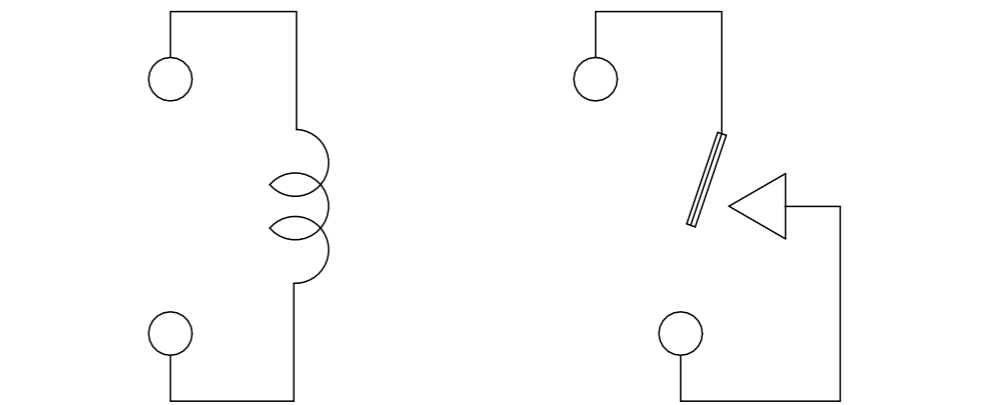
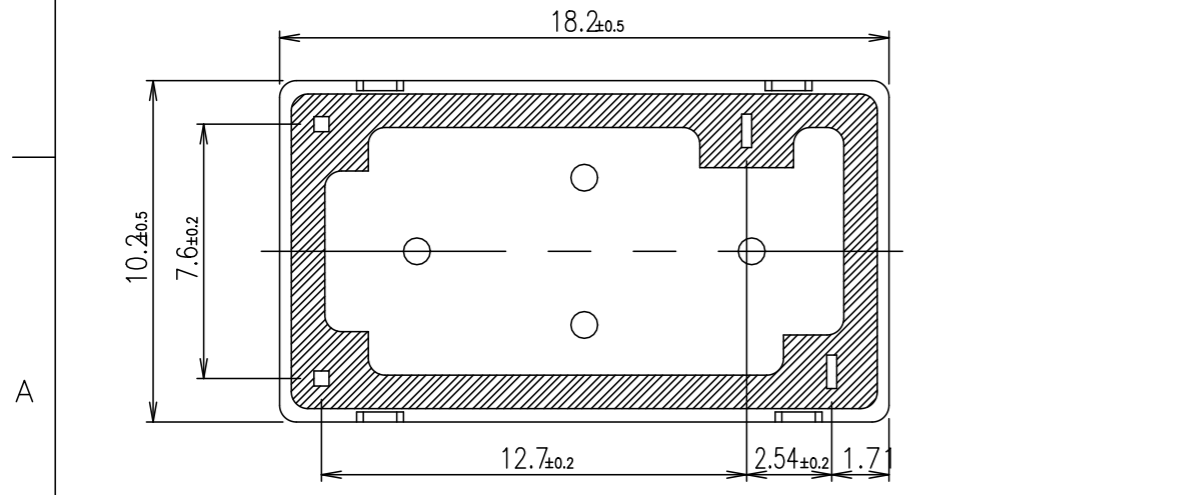
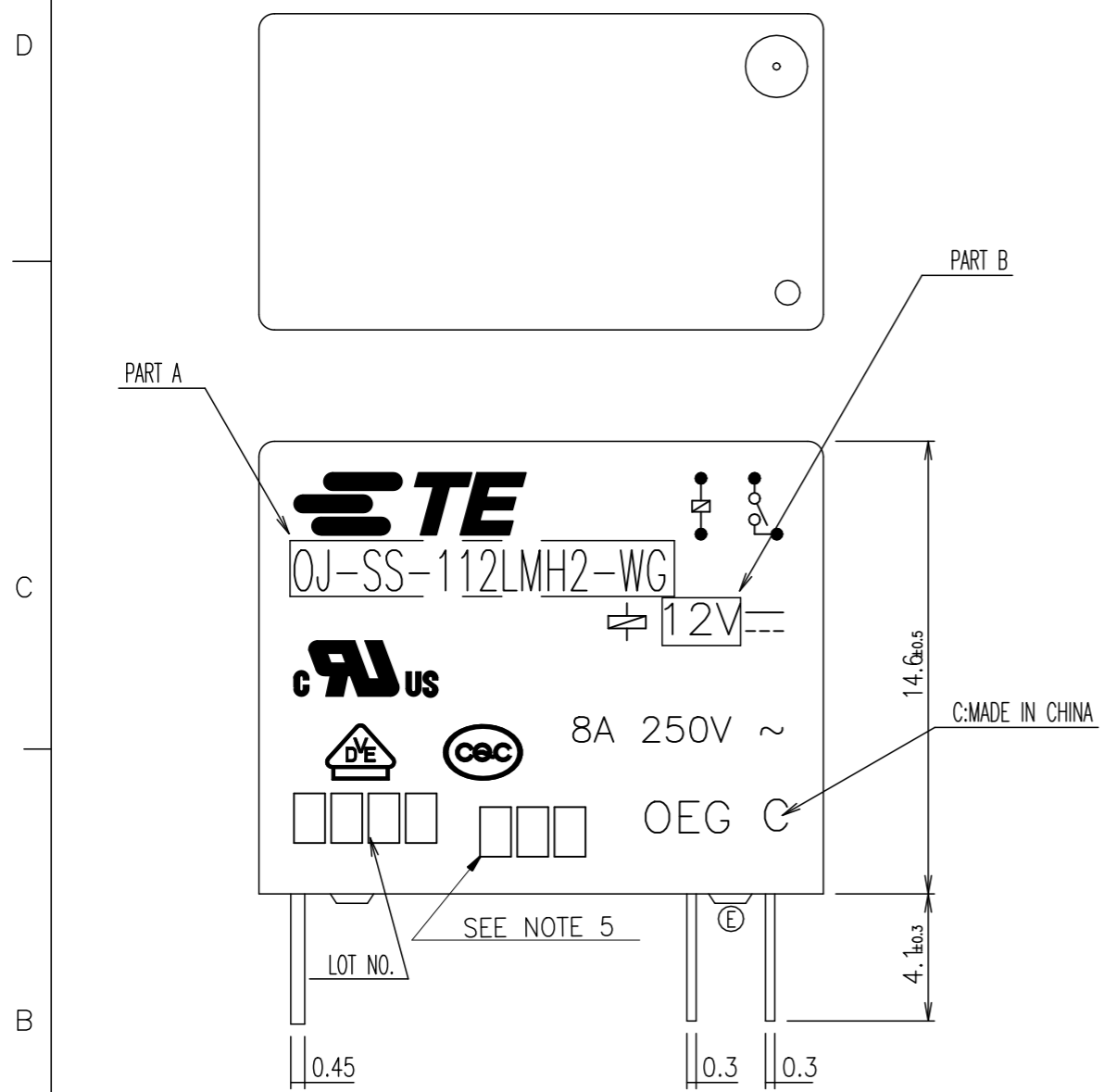

FIGURE FOR PRINTED CIRCUIT BOARD PROCESSING (BOTTOM VIEW)

THIS DRAWING IS A CONTROLLED DOCUMENT.		DWN	24AUG2012		 TE Connectivity
DIMENSIONS: mm		CHK	FU.BO		
TOLERANCES UNLESS OTHERWISE SPECIFIED:		APVD	N,FUNAYAMA		
0 PLC ± - 1 PLC ± - 2 PLC ± - 3 PLC ± - 4 PLC ± - ANGLES ± -		NAME	XIAONING,ZHANG		
MATERIAL		PRODUCT SPEC	-		OJ-SS-LMH2-WG SPEC,000
		APPLICATION SPEC	-		RESTRICTED TO
		WEIGHT	SIZE	CAGE CODE	DRAWING NO
			A3	00779	1721874
CUSTOMER DRAWING			SCALE	SHEET	REV
			5:1	1 OF 2	E2

4

3

2

1

THIS DRAWING IS UNPUBLISHED.

RELEASED FOR PUBLICATION

-, -

© COPYRIGHT - By - TE CONNECTIVITY

ALL RIGHTS RESERVED.

REVISIONS

P	LTR	DESCRIPTION	DATE	DWN	APVD
-	-	SEE SHEET 1	-	-	-

②	107-84030	1-1721874-0	OJ-SS-112LMH2-WG	12V	OJ-SS-112LMH2-WG	i
②	107-84030	1721874-9	OJ-SS-124LMH2-WG	24V	OJ-SS-124LMH2-WG	h
③	107-84030	1721874-8	OJ-SS-124LMH2-WG	24V	OJ-SS-124LMH2-WG	g
107-79010	1721874-6	OJ-SS-124LMH2-WG	24V	OJ-SS-124LMH2-WG	f	
	1721874-5	OJ-SS-112LMH2-WG	12V	OJ-SS-112LMH2-WG	e	
	1721874-4	OJ-SS-109LMH2-WG	9V	OJ-SS-109LMH2-WG	d	
	1721874-3	OJ-SS-106LMH2-WG	6V	OJ-SS-106LMH2-WG	c	
	1721874-2	OJ-SS-105LMH2-WG	5V	OJ-SS-105LMH2-WG	b	
	1721874-1	OJ-SS-103LMH2-WG	3V	OJ-SS-103LMH2-WG	a	
PACKAGE SPEC	TE PART NO	DESCRIPTION	PART B	PART A	TYPE	

Diagram dimension	Tolerance
0.99mm max.	±0.1mm
1 - 2.99mm	±0.2mm
3mm min.	±0.3mm

RELAY TYPE

NOTES:

- 1. TERMINAL DIMENSION BEFORE TINNING.
- 2. LOT NO. SYSTEM AS FOLLOWING:



WEEK
YEAR

- 2. TERMINAL DIMENSION IS BEFORE SOLDER DIP;
- 3. FOR THE TIN-PLATING OF THE PINS:
+0.1mm FOR WIDTH, THICKNESS AND DIAMETER.
+0.5mm FOR LENGTH.
- 4. MARKING FROM INK TO LASER AND USING WELDING CONTACT

5. ADD LOT NO. SYSTEM AS FOLLOWING;



- I, DIGITS FOR DAY OF THE WEEK
1...MONDAY IN THIS WEEK;
2...TUESDAY IN THIS WEEK;
7...SUNDAY IN THIS WEEK
- II, DIGITS FOR SHIFT OF THE DAY
1...DAY SHIFT IN THIS DAY;
2...NIGHT SHIFT IN THIS DAY;
- III, ONE CHARACTER DISTINGUISH THE LINE IDENTITY, SUCH AS: A,B,....Z

		EPOXY RESIN	SEAL (BASE & BOBBIN)	15
		MW79	MAGNETIC WIRE	14
94V-0		NYLON	CASE	13
94V-0		P.E.T	BASE	12
94V-0		NYLON	BOBBIN	11
	SOLDER DIP	C.P WIRE	COIL TERMINAL	10
94V-0		P.P.S	CARD	9
		Ag ALLOY	MOVABLE CONTACT	8
		Ag ALLOY	NO.CONTACT	7
		STEEL	HINGE SPRING	6
	SOLDER DIP	Cu ALLOY	NO.TERMINAL	5
	SOLDER DIP	Cu ALLOY	MOVABLE SPRING	4
	NIP	STEEL	CORE	3
	NIP	STEEL	ARMATURE	2
	NIP	STEEL	YOKE	1
INCOMBUSTIBILITY	TREATMENT	MATERIAL	DESCRIPTION	ITEM

THIS DRAWING IS A CONTROLLED DOCUMENT.		DWN	24AUG2012		
		CHK	FU.BO		
		APVD	N,FUNAYAMA		
		PRODUCT SPEC	XIAONING,ZHANG		
DIMENSIONS: mm		TOLERANCES UNLESS OTHERWISE SPECIFIED:		NAME	
		0 PLC ± - 1 PLC ± - 2 PLC ± - 3 PLC ± - 4 PLC ± - ANGLES ± -		OJ-SS-LMH2-WG SPEC,000	
MATERIAL		FINISH		SIZE	
				CAGE CODE	
				DRAWING NO	
				RESTRICTED TO	
		WEIGHT		0	
				A3 00779	
				C=1721874	
		CUSTOMER DRAWING		SCALE	
				5:1	
				SHEET	
				2 OF 2	
				REV	
				E2	