

REV.	DATE	ECR NO.	DESCRIPTION
NC	06/24/09	XXXXXX	INITIAL RELEASE

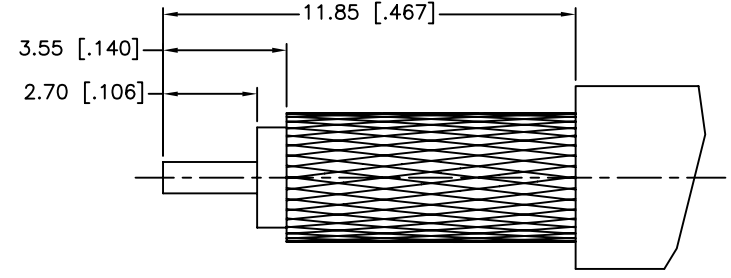
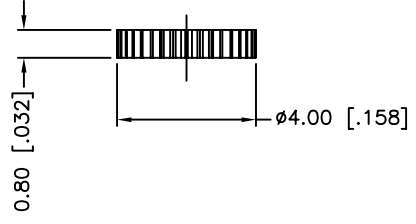
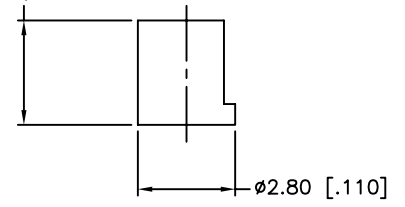
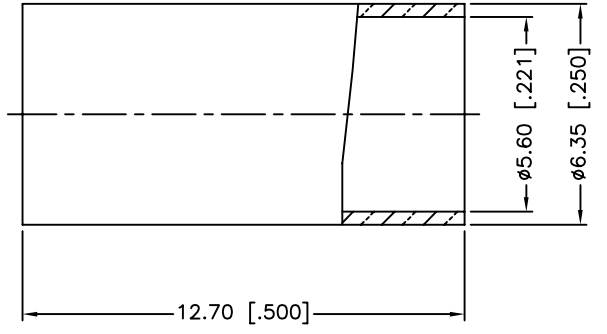
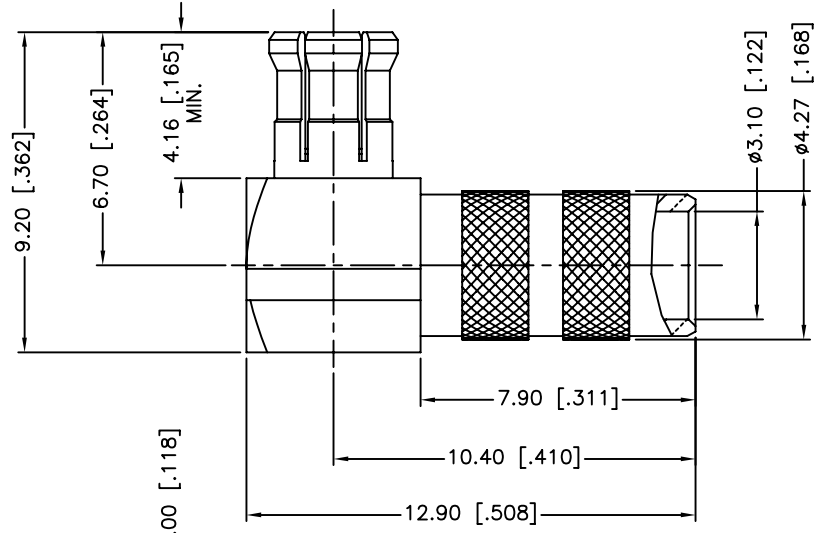
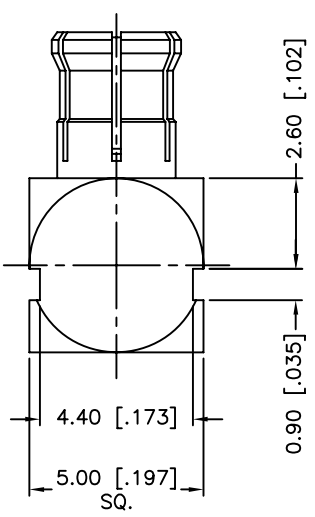

RECOMMENDED  
CABLE STRIPPING DIM'S

1. CRIMPED FERRULE  
HEX CRIMP SIZE .213"
2. CONTACT PIN TO SOLDER

7	FERRULE	BRASS	GOLD	1
6	COVER	BRASS	GOLD	1
5	INSULATOR	DELTRIN	NATURAL	1
4	CONTACT PIN	BRASS	GOLD	1
3	INSULATOR	PTFE	NATURAL	1
2	BODY	BER. COPPER	GOLD	1
1	HOUSING	BRASS	GOLD	1
	DESCRIPTION	MATERIAL	FINISH	QTY

UNLESS OTHERWISE SPECIFIED DIMENSIONS ARE IN MILLIMETERS; DIMENSIONS IN [ ] ARE IN INCHES AND FOR CUSTOMER REFERENCE ONLY.

UNLESS OTHERWISE SPECIFIED TOLERANCES FOR MILLIMETERS ARE:  
0.5 - 8mm ± 0.20mm  
8 - 30mm ± 0.40mm  
30 - 120mm ± 0.50mm

UNLESS OTHERWISE SPECIFIED TOLERANCES FOR INCHES ARE:  
.020 - .315 = ± 0.007"  
.315 - 1.180 = ± 0.015"  
1.180 - 4.724 = ± 0.020"

DO NOT SCALE DRAWING

APPROVALS	DATE
DRAWN M.ZHANG	06/24/09
CHECKED	
ISSUED	
SHEET 1 OF 1	
CAD FILE	C:/CONNEX/252123.DWG

**Amphenol Connex**

PART DESCRIPTION  
**MCX R/A CRIMP PLUG  
(FOR RG-55/U,142A/U, 223/U, 400/U)**

PART NO.  
**252123**

DWG. NO. 252123.DWG    REV. NC    SIZE A    SCALE NA