

SMA 2.9 MALE - SMP MALE FULL DETENT

R191.966.001

STRAIGHT ADAPTER - PACK. 100

Série : ADAPT

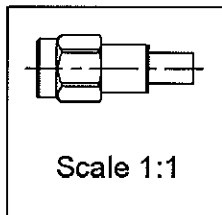
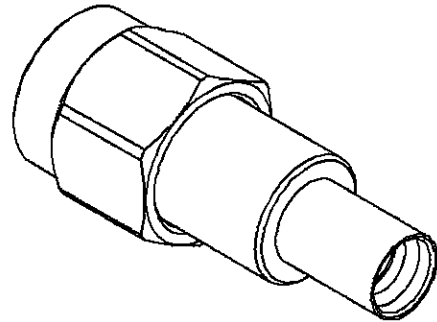
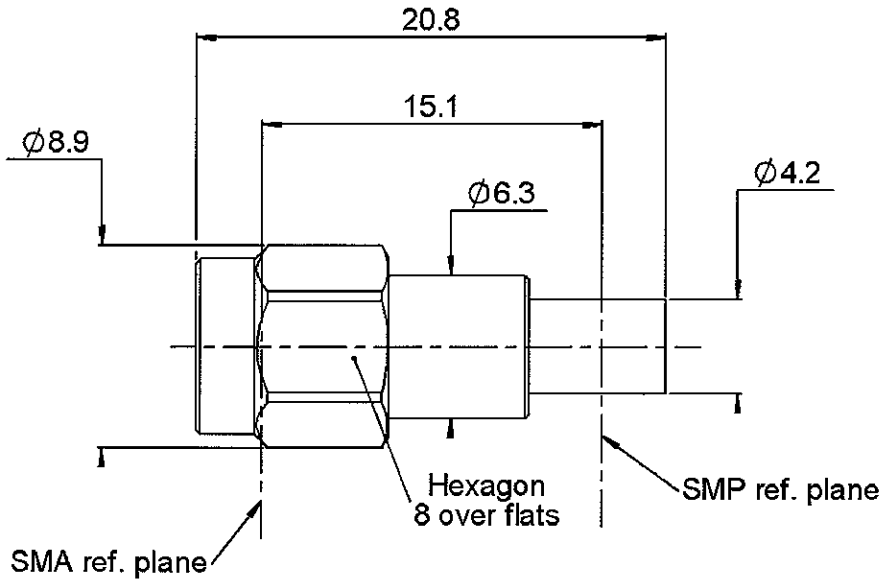

All dimensions are in mm.

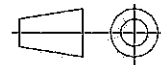

COMPONENTS	MATERIALS	PLATINGS (µm)
BODY	STAINLESS STEEL	PASSIVATED
CENTER CONTACT	BERYLLIUM COPPER	GOLD 1.27 OVER NICKEL 1.27
OUTER CONTACT	BRASS	GOLD 0.2 OVER NICKEL 2
INSULATOR	PTFE+KAPTON	
GASKET	SILICONE RUBBER	
OTHERS PARTS	STAINLESS STEEL	PASSIVATED
-	-	
-	-	

Issue : 0529 B

In the effort to improve our products, we reserve the rights to make changes judged to be necessary.



SMA 2.9 MALE - SMP MALE FULL DETENT

R191.966.001

STRAIGHT ADAPTER - PACK. 100

Série : ADAPT

PACKAGING

Standard	Unit	Other
100	'W' option	Contact us

SPECIFICATION

ELECTRICAL CHARACTERISTICS

Impedance		50 Ω
Frequency		0-40 GHz
VSWR	1.40 +	0.000 x F(GHz) Maxi
Insertion loss		0.1 √F(GHz) dB Maxi
RF leakage	-(NA - F(GHz)) dB Maxi
Voltage rating		335 Veff Maxi
Dielectric withstanding voltage		500 Veff mini
Insulation resistance		5000 MΩ mini

ENVIRONMENTAL

Operating	-65/+165 °C
Hermetic seal	NA Atm.cm3/s
Panel leakage	NA

MECHANICAL CHARACTERISTICS

Center contact retention		
Axial force – Mating end		27 N mini
Axial force – Opposite end		27 N mini
Torque		NA N.cm mini
Recommended torque		
Mating	SMA2.	0 N.cm
	SMP	0 N.cm
	-	0 N.cm
Panel nut		NA N.cm
Mating life		100 Cycles mini
Weight		3.800 g

OTHERS CHARACTERISTICS

Issue : 0529 B

In the effort to improve our products, we reserve the rights to make changes judged to be necessary.



RADIALL®

PRELIMINARY