

ITEM NO.	CKT SIZE	HOUSING MATERIAL	PLATING	DIM A	DIM B	VOIDED CIRCUITS	DRAIN HOLES		
46014-0400	4	V-0	TIN	$\frac{.709}{(18.00)}$	$\frac{.496}{(12.60)}$	NONE	YES		
46014-0401		V-2							
46014-0402		V-0							
46014-0403		V-2							
46014-0500	5	V-0	TIN	$\frac{.874}{(22.20)}$	$\frac{.661}{(16.80)}$		NONE	NO	
46014-0502		V-0	GOLD						
46014-0404	4	V-0	TIN	$\frac{.709}{(18.00)}$	$\frac{.496}{(12.60)}$			NONE	NO
46014-0405		V-2							
46014-0406		V-0							
46014-0407		V-2							
46014-0503	5	V-0	TIN	$\frac{.874}{(22.20)}$	$\frac{.661}{(16.80)}$	NONE			NO
46014-0504		V-0	GOLD						

PART NUMBERS WITH VOIDED CIRCUITS

ITEM NO.	CKT SIZE	HOUSING MATERIAL	PLATING	DIM A	DIM B	VOIDED CIRCUITS	DRAIN HOLES
46014-5001	5	V-0	GOLD	$\frac{.874}{(22.20)}$	$\frac{.661}{(16.80)}$	3	NO

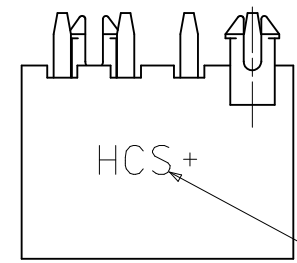

SEE NOTE 8

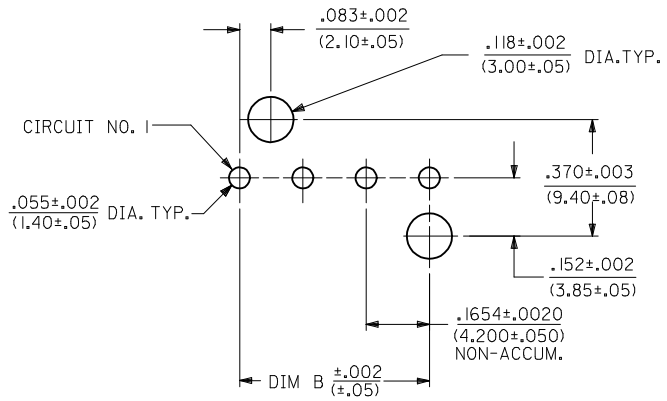
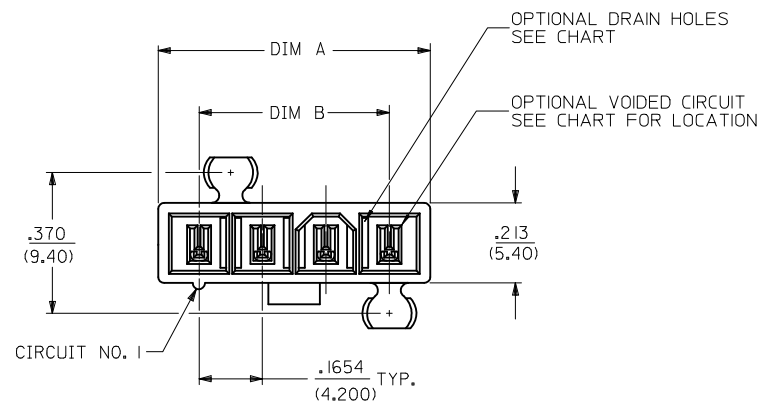

RECOMMENDED HOLE LAYOUT FOR .070/(1.78) MAX. THICK P. C. BOARD

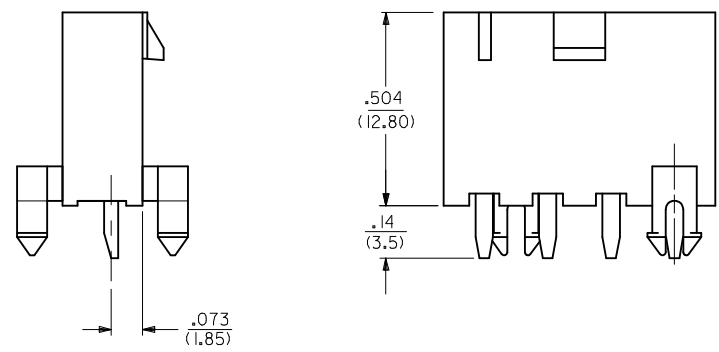

- NOTES:
- MATERIALS:
HOUSING: 1 - NYLON 6/6, UL 94V-2, COLOR: NATURAL
2 - NYLON 6/6, UL 94V-0, COLOR: NATURAL
TERMINALS: COPPER ALLOY
 - TERMINAL PLATING:
1 - .000100/(.00254) MIN. BRIGHT TIN OVER
.000050/(.00127) MIN. NICKEL OVERALL
2 - .000030/(.00076) MIN. SELECT GOLD AND
.000100/(.00254) MIN. SELECT MATTE TIN OVER
.000050/(.00127) MIN. NICKEL OVERALL
 - PRODUCT SPECIFICATION: PS-45750-001
 - PACKAGING: TRAY PACK PER PK-5566-002
 - PART MATES WITH WITH MINI-FIT JR. RECEPTACLE #5557.
 - PART IS NOT DESIGNED FOR CURRENT SHARING.
 - PARTS TO HAVE "HCS+" MARKING.
 - PART CONFORMS TO CLASS "B" REQUIREMENTS OF COSMETIC SPECIFICATION PS-45499-002.

TRAY PACKAGING EC NO: UCP2010-0593 DRWN: JAGUILAR 2009/09/15 CHKD: J BELL 2009/09/24 APPR: F SMITH 2009/09/24	QUALITY SYMBOLS ▽=0 ▽=0	GENERAL TOLERANCES (UNLESS SPECIFIED)		DIMENSION STYLE IN/MM	SCALE 1:1	DESIGN UNITS METRIC	THIRD ANGLE PROJECTION	
		4 PLACES ± --- ± --- 3 PLACES ± --- ± .010 2 PLACES ± 0.25 ± .015 1 PLACE ± 0.38 ± --- ANGULAR ± 1/2°	mm INCH	DRAWN BY TGREGORI	DATE 2006/04/27	TITLE VERTICAL HEADER ASSEMBLY SINGLE ROW, 4 & 5 CKT MINI-FIT PLUS HCS SERIES		
A2	REV	DRAFT WHERE APPLICABLE MUST REMAIN WITHIN DIMENSIONS		APPROVED BY JCOMERCI		DATE 2006/04/27		MOLEX INCORPORATED
		SEE CHART		MATERIAL NO. DOCUMENT NO.		SHEET NO. 1 OF 1		SD-46014-001