

SEE TABLE FOR
THREAD TYPE ▽

Last Pos.

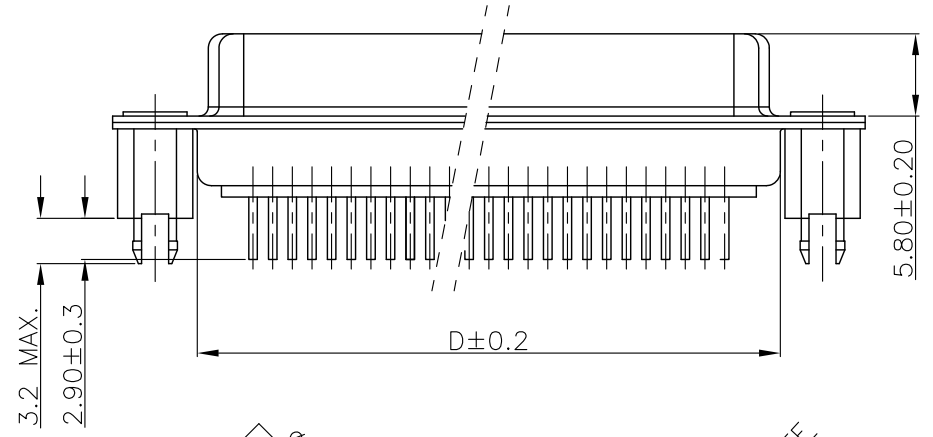

3.2 MAX.
2.90±0.3

5.80±0.20

D±0.2

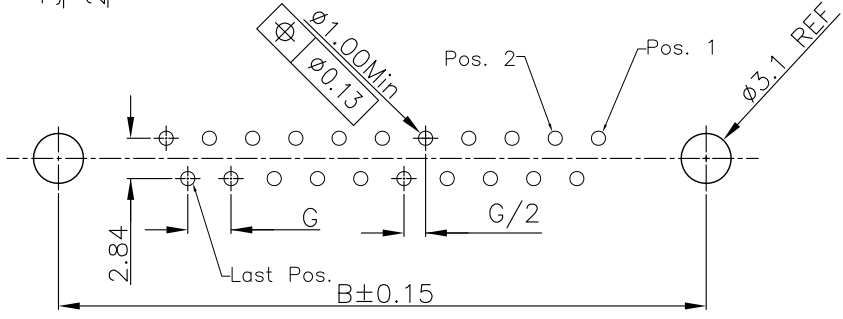

P.C.B LAYOUT
t: 1.6±0.1MM

REMARK:

1. CHARACTERISTICS:
 RATED VOLTAGE: 250V
 RATED CURRENT: 5AMP
 CONTACT RESISTANCE: 25mohms MAX. INITIAL; 40mohms MAX. AFTER.
 INSULATION RESISTANCE: 5000Mohms MIN. at 500V DC
 DIELECTRIC STRENGTH: 1000VRMS
 OPERATING TEMPERATURE RANGE: -55°C ~ 105°C
 INSERTION/EXTRACTION FORCE PER CONTACT: 5N Max. / 0.3N Min.
 MATING/UNMATING CYCLES: 50MATINGS MIN.

2. MATERIAL:

- INSULATORS: GLASS-FILLED THERMOPLASTIC UL94V-0, COLOR IN BLACK.
 CONTACTS: COPPER ALLOY, SELECTIVE GOLD ON CONTACT AREA,
 100u" Min MATTE TIN TOP OVER SOLDER AREA,
 30u" Min NICKEL UNDER PLATE.
 SHELL: STEEL, 100u" Min NICKEL TOP OVER,
 50u" Min COPPER UNDER PLATE.
 CLINCH NUT: COPPER ALLOY, 100u" Min MATTE TIN PLATED.

3. PART NUMBER DESCRIPTION: **10090098-S XX X X LF**

- SERIES NO. _____ LF: ROHS COMPLIANT
 TYPE _____ FLANGE MOUNTING OPTION
 S: SOCKET (FEMALE) X: UNC #4-40 CLINCHNUTS
 L: M3 CLINCHNUTS
 NUMBER OF CONTACTS _____ CONTACT FINISH
 09: 9-PIN 4: GOLD FLASH
 15: 15-PIN 6: 30u" PLATING OPTION
 25: 25-PIN AVAILABLE ON REQUEST
 37: 37-PIN

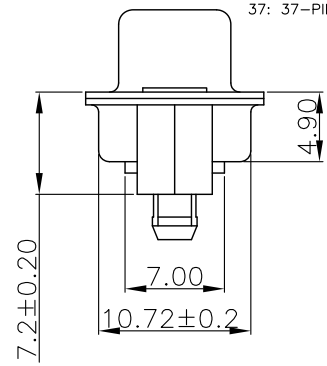

7.2±0.20

4.90

7.00

10.72±0.2

POS.	PART NO.	THREAD TYPE
9	10090098-S09*LLF	M3X0.5
15	10090098-S15*LLF	M3X0.5
25	10090098-S25*LLF	M3X0.5
37	10090098-S37*LLF	M3X0.5
9	10090098-S09*XLF	UNC 4-40
15	10090098-S15*XLF	UNC 4-40
25	10090098-S25*XLF	UNC 4-40
37	10090098-S37*XLF	UNC 4-40

POS.	A	B	C	D	G
09	30.81	24.99	16.33	19.28	2.74
15	39.24	33.32	24.66	27.75	2.74
25	53.04	47.04	38.38	41.30	2.77
37	69.32	63.50	54.84	57.40	2.77

mat'l. code				tolerances unless otherwise specified			CUSTOMER COPY		FCI www.fciconnect.com	
ltr	ecn no	dr	date	linear	.X ± 0.38		projection	title		
A	T09-1033	J.H	3/13/09		.XX ± 0.25			D-SUB FEMALE STRAIGHT		
B	T09-1044	J.H	4/2/09		.XXX ± 0.10			product family D-SUB code TWN		
C	ELX-I-15340	MP	07/25/13	angles	0° ± 2°		scale 1:1	size 10090098		sheet 1 of 2
sheet index		revision sheet	C 1	C 2				A4		

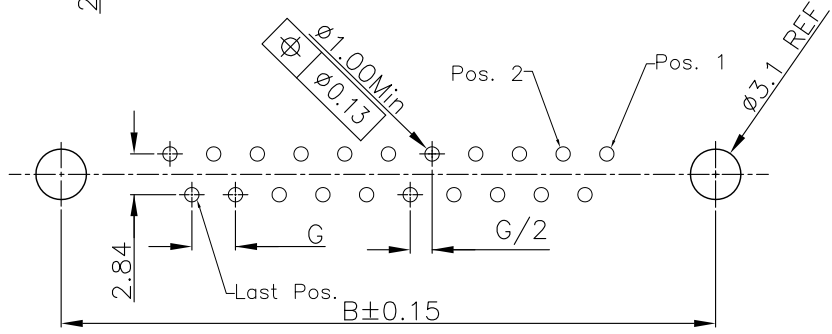
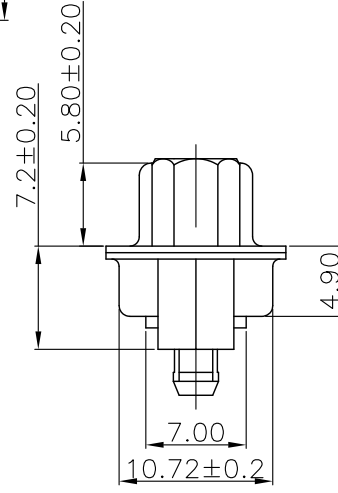
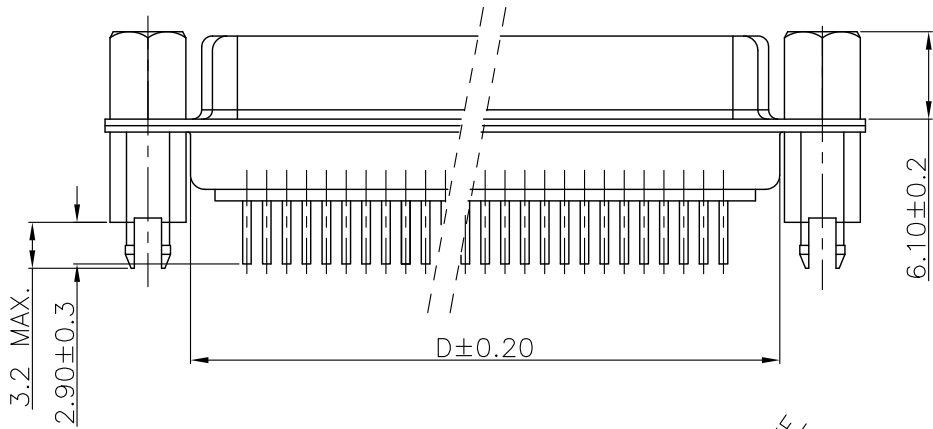
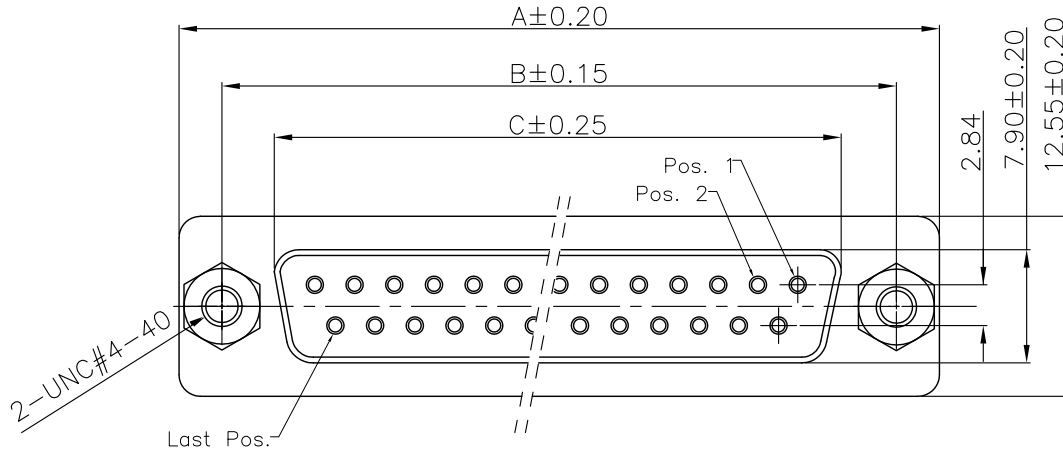

P.C.B LAYOUT
t: 1.6±0.1MM

REMARK:
1. CHARACTERISTICS:
RATED VOLTAGE: 250V
RATED CURRENT: 5AMP
CONTACT RESISTANCE: 25mohms MAX. INITIAL; 40mohms MAX. AFTER.
INSULATION RESISTANCE: 5000Mohms MIN. at 500V DC
DIELECTRIC STRENGTH: 1000VRMS
OPERATING TEMPERATURE RANGE: -55°C~105°C
INSERTION/EXTRACTION FORCE PER CONTACT: 5N Max. /0.3N Min.
MATING/UNMATING CYCLES: 50MATINGS MIN.

2. MATERIAL:
INSULATORS: GLASS-FILLED THERMOPLASTIC UL94V-0, COLOR IN BLACK.
CONTACTS: COPPER ALLOY, SELECTIVE GOLD ON CONTACT AREA,
100u" Min MATTE TIN TOP OVER SOLDER AREA,
30u" Min NICKEL UNDER PLATE.
SHELL: STEEL, 100u" Min NICKEL TOP OVER,
50u" Min COPPER UNDER PLATE.
CLINCH NUT: COPPER ALLOY, 100u" Min MATTE TIN PLATED.
SCREW LOCK: COPPER ALLOY, 100u" Min BRIGHT NICKEL PLATED.

3. PART NUMBER DESCRIPTION: **10090098-S XX X X LF**
SERIES NO. _____ LF: ROHS COMPLIANT
TYPE _____ FLANGE MOUNTING OPTION
S: SOCKET (FEMALE) v: UNC #4-40 SCREWLOCKS
NUMBER OF CONTACTS _____ CONTACT FINISH
09: 9-PIN 4: FLASH GOLD
15: 15-PIN 6: 30u" PLATING OPTION AVAILABLE
25: 25-PIN ON REQUEST
37: 37-PIN

POS.	PART NO.	A	B	C	D	G
09	10090098-S09*VLF	30.81	24.99	16.33	19.28	2.74
15	10090098-S15*VLF	39.24	33.32	24.66	27.75	2.74
25	10090098-S25*VLF	53.04	47.04	38.38	41.30	2.77
37	10090098-S37*VLF	69.32	63.50	54.84	57.40	2.77

mat'l. code				tolerances unless otherwise specified			CUSTOMER COPY		FCI		www.fciconnect.com	
ltr	ecn no	dr	date	linear	.X ± 0.38		projection	title				
c					.XX ± 0.25			D-SUB FEMALE STRAIGHT				
					.XXX ± 0.10							
				angles	0° ±2°		MM		product family D-SUB		code	
				dr	JASON HSU	3/12/09	scale		size		TWN	
				enr	JASON HSU	3/12/09	1:1		dwg no		sheet	
				chr	MITHUN PAUL	07/25/13	A4		10090098		2 of 2	
				appd	BIJU K PAUL	07/25/13						
sheet index	revision sheet											