

# FAN4800AS/CS/01S/2S

## PFC/PWM Controller Combination

### Features

- Pin-to-Pin Compatible with ML4800 and FAN4800 and CM6800 and CM6800A
- PWM Configurable for Current Mode or Feedforward Voltage-Mode Operation
- Internally Synchronized Leading-Edge PFC and Trailing-Edge PWM in One IC
- Low Operating Current
- Innovative Switching-Charge Multiplier Divider
- Average-Current Mode for Input-Current Shaping
- PFC Over-Voltage and Under-Voltage Protections
- PFC Feedback Open-Loop Protection
- Cycle-by-Cycle Current Limiting for PFC/PWM
- Power-on Sequence Control and Soft-Start
- Brownout Protection
- Interleaved PFC/PWM Switching
- Improved Efficiency at Light Load
- $f_{RTCT}=4 \cdot f_{PFC}=4 \cdot f_{PWM}$  for FAN4800AS/01S
- $f_{RTCT}=4 \cdot f_{PFC}=2 \cdot f_{PWM}$  for FAN4800CS/02S

### Applications

- Desktop PC Power Supply
- Internet Server Power Supply
- LCD TV, Monitor Power Supply
- UPS
- Battery Charger
- DC Motor Power Supply
- Monitor Power Supply
- Telecom System Power Supply
- Distributed Power

### Related Resources

- [AN-8027 - FAN480X PFC+PWM Combination Controller Application](#)

### Description

The highly integrated FAN4800AS/CS/01S/02S parts are specially designed for power supplies that consist of boost PFC and PWM. They require very few external components to achieve versatile protections / compensation. They are available in 16-pin DIP and SOP packages.

The PWM can be used in either current or voltage mode. In voltage mode, feed-forward from the PFC output bus can reduce the secondary output ripple.

Compared with older productions, ML4800 and FAN4800, FAN4800AS/CS/01S/02S have lower operation current that saves power consumption in external devices. FAN4800AS/CS/01S/02S have accurate 49.9% maximum duty of PWM that makes the hold-up time longer. Brownout protection and PFC soft-start functions available in this series are not available in ML4800 and FAN4800.

To evaluate FAN4800AS/CS/01S/02S for replacing existing FAN4800 and ML4800 boards, five things must be completed before the fine-tuning procedure:

1. Change  $R_{AC}$  resistor from the old value to a higher resistor: between 6 M $\Omega$  to 8 M $\Omega$ .
2. Change RT/CT pin from the existing values to  $R_T=6.8k\Omega$  and  $C_T=1000$  pF to have  $f_{PFC}=64$  kHz and  $f_{PWM}=64$  kHz.
3. The VRMS pin needs to be 1.224 V at  $V_{IN}=85 V_{AC}$  for universal input application from line input from 85  $V_{AC}$  to 270  $V_{AC}$ .
4. At full load, the average  $V_{VEA}$  needs to be  $\sim 4.5$  V and the ripple of  $V_{VEA}$  needs to be less than 400 mV.
5. For the Soft-Start pin, the soft-start current has been reduced to half the FAN4800 capacitor.

There are two differences from FAN4800A/C/01/02 to FAN4800AS/CS/01S/02S:

1. Under-voltage protection debounce time is extended to one second.
2. PWM gate clamp voltage is raised to 19 V.



Application Diagram

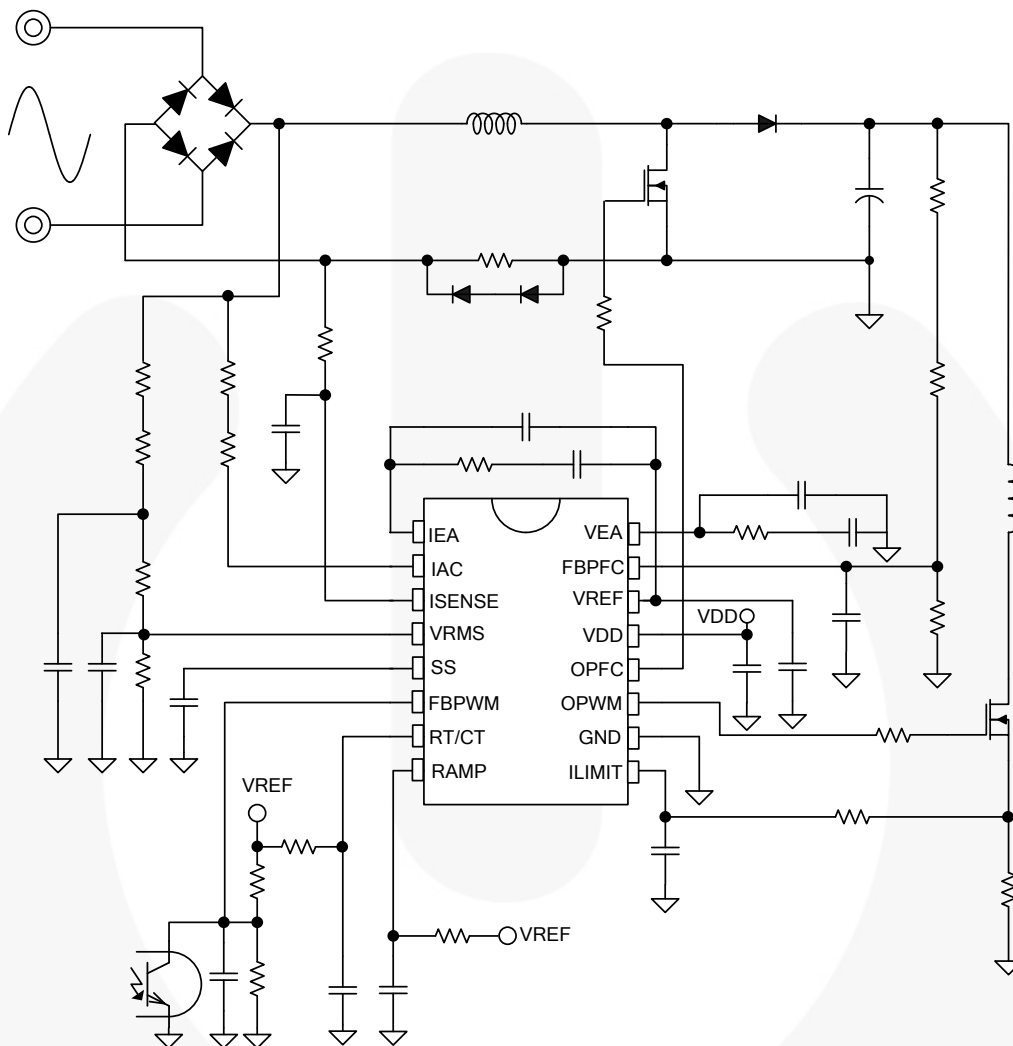

Figure 2. Typical Application, Voltage Mode

Block Diagram

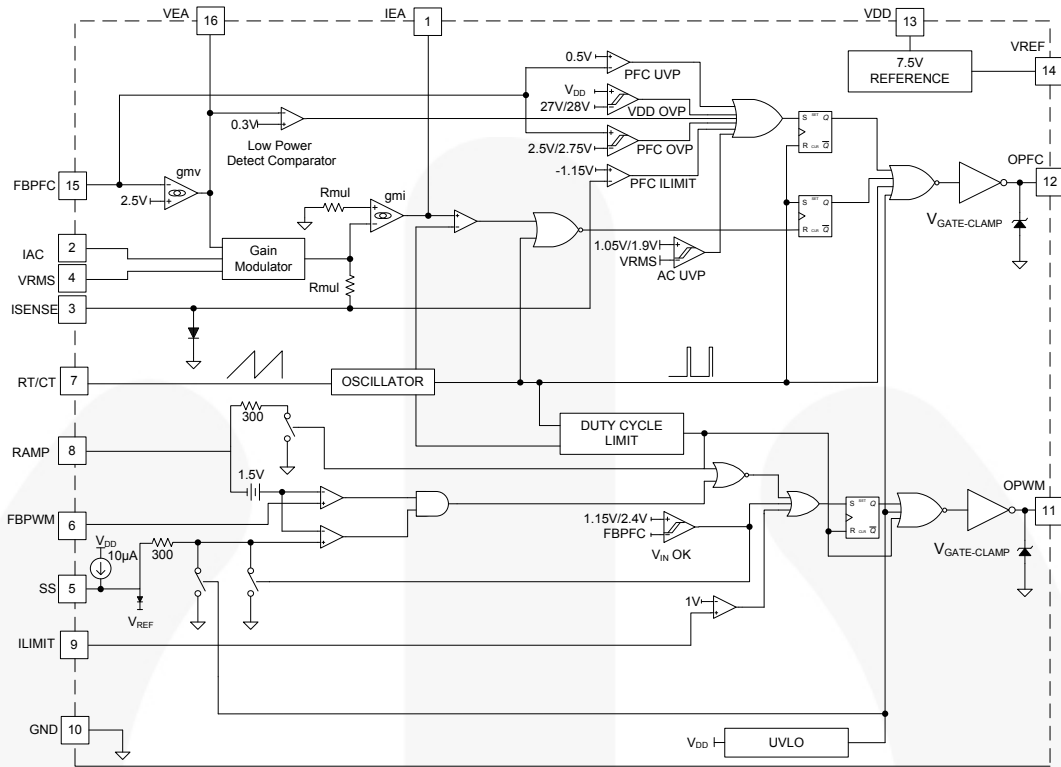

Figure 3. FAN4800AS/CS Function Block Diagram

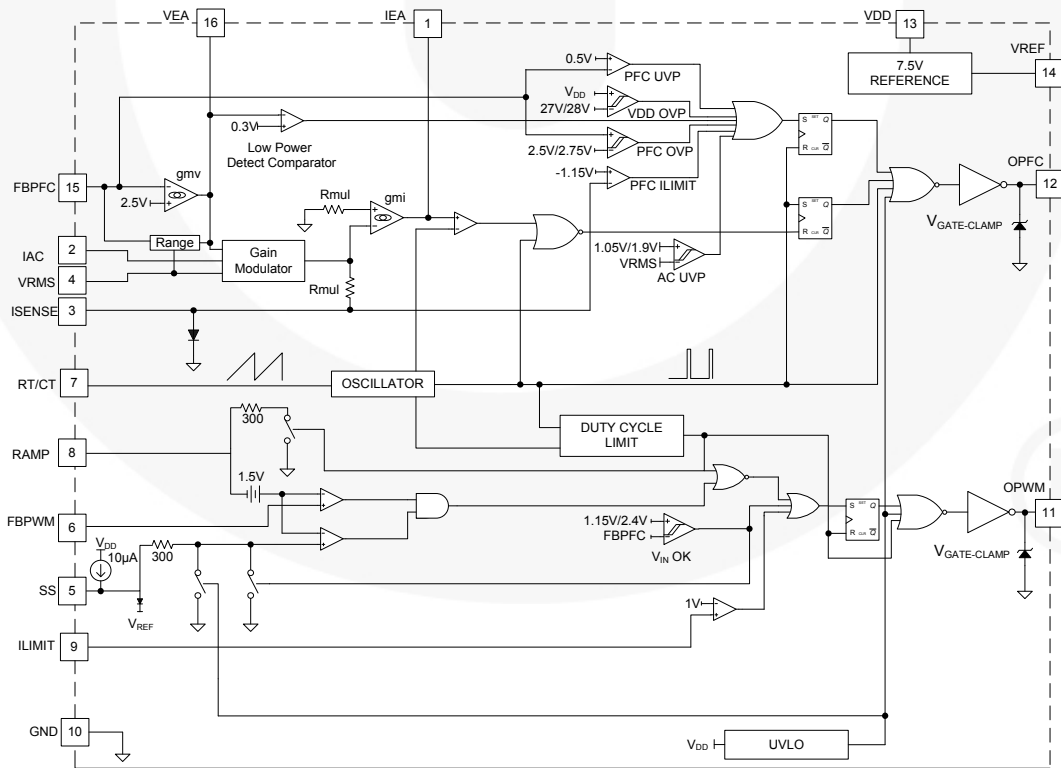
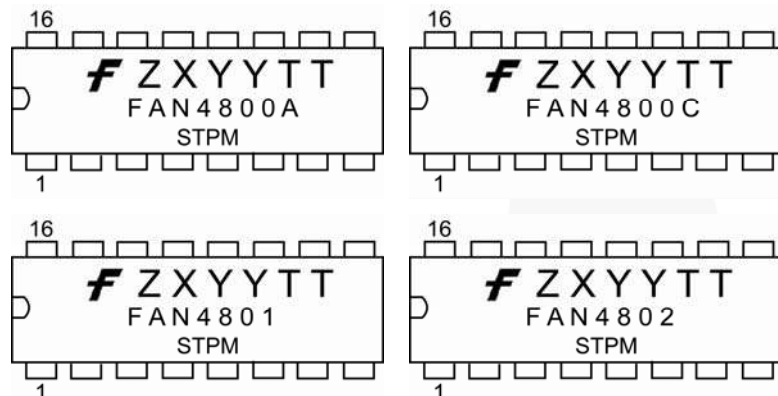

Figure 4. FAN4801S/02S Function Block Diagram

### Marking Information



**F** – Fairchild Logo  
**Z** – Plant Code  
**X** – 1-Digit Year Code  
**YY** – 2-Digit Week Code  
**TT** – 2-Digit Die-Run Code  
**T** – Package Type (N:DIP)  
**P** – Y: Green Package  
**M** – Manufacture Flow Code

Figure 5. DIP Top Mark

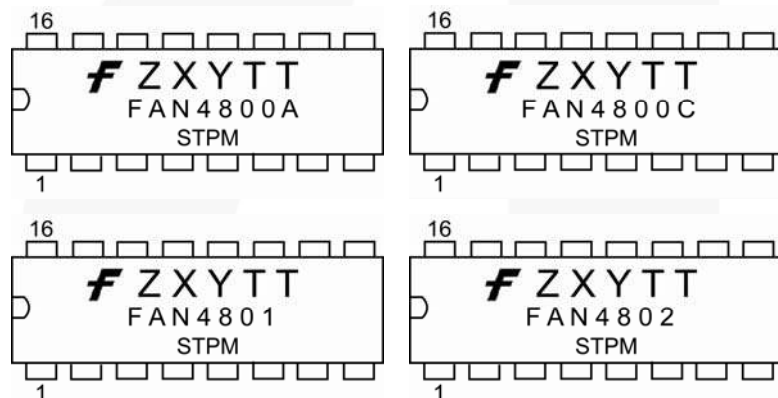

**F** – Fairchild Logo  
**Z** – Plant Code  
**X** – 1-Digit Year Code  
**Y** – 1-Digit Week Code  
**TT** – 2-Digit Die-Run Code  
**T** – Package Type (M:SOP)  
**P** – Y: Green Package  
**M** – Manufacture Flow Code

Figure 6. SOP Top Mark

## Pin Configuration

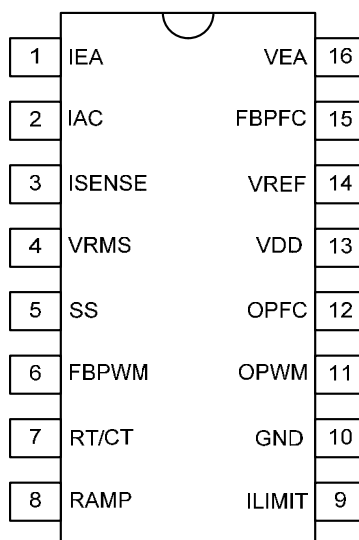

Figure 7. Pin Configuration (Top View)

## Pin Definitions

Pin #	Name	Description
1	IEA	<b>Output of PFC Current Amplifier.</b> The signal from this pin is compared with an internal sawtooth to determine the pulse width for PFC gate drive.
2	IAC	<b>Input AC Current.</b> For normal operation, this input provides current reference for the multiplier. The suggested maximum IAC is 100 $\mu$ A.
3	ISENSE	<b>PFC Current Sense.</b> The non-inverting input of the PFC current amplifier and the output of multiplier and PFC ILIMIT comparator.
4	VRMS	<b>Line-Voltage Detection.</b> The pin is used for the PFC multiplier.
5	SS	<b>PWM Soft-Start.</b> During startup, the SS pin charges an external capacitor with a 10 $\mu$ A constant current source. The voltage on FBPWM is clamped by SS during startup. If a protection condition occurs and/or PWM is disabled, the SS pin is quickly discharged.
6	FBPWM	<b>PWM Feedback Input.</b> The control input for voltage-loop feedback of PWM stage.
7	RT/CT	<b>Oscillator RC Timing Connection.</b> Oscillator timing node; timing set by $R_T$ and $C_T$ .
8	RAMP	<b>PWM RAMP Input.</b> In current mode, this pin functions as the current-sense input; when in voltage mode, it is the feedforward sense input from PFC output 380 V (feedforward ramp).
9	ILIMIT	<b>Peak Current Limit Setting for PWM.</b> The peak current limits setting for PWM.
10	GND	<b>Ground.</b>
11	OPWM	<b>PWM Gate Drive.</b> The totem-pole output drive for PWM MOSFET. This pin is internally clamped under 19 V to protect the MOSFET.
12	OPFC	<b>PFC Gate Drive.</b> The totem-pole output drive for PFC MOSFET. This pin is internally clamped under 15 V to protect the MOSFET.
13	VDD	<b>Supply.</b> The power supply pin. The threshold voltages for startup and turn-off are 11 V and 9.3 V, respectively. The operating current is lower than 10 mA.
14	VREF	<b>Reference Voltage.</b> Buffered output for the internal 7.5 V reference.
15	FBPFC	<b>Voltage Feedback Input for PFC.</b> The feedback input for PFC voltage loop. The inverting input of PFC error amplifier. This pin is connected to the PFC output through a divider network.
16	VEA	<b>Output of PFC Voltage Amplifier.</b> The error amplifier output for PFC voltage feedback loop. A compensation network is connected between this pin and ground.

## Absolute Maximum Ratings

Stresses exceeding the absolute maximum ratings may damage the device. The device may not function or be operable above the recommended operating conditions and stressing the parts to these levels is not recommended. In addition, extended exposure to stresses above the recommended operating conditions may affect device reliability. The absolute maximum ratings are stress ratings only.

Symbol	Parameter	Min.	Max.	Unit
V <sub>DD</sub>	DC Supply Voltage		30	V
V <sub>H</sub>	SS, FBPWM, RAMP, OPWM, OPFC, VREF	-0.3	30.0	V
V <sub>L</sub>	IAC, VRMS, RT/CT, ILIMIT, FBPF, VEA	-0.3	7.0	V
V <sub>IEA</sub>	IEA	0	V <sub>VREF</sub> +0.3	V
V <sub>N</sub>	ISENSE	-5.0	0.7	V
I <sub>AC</sub>	Input AC Current		1	mA
I <sub>REF</sub>	V <sub>REF</sub> Output Current		5	mA
I <sub>PFC-OUT</sub>	Peak PFC OUT Current, Source or Sink		0.5	A
I <sub>PWM-OUT</sub>	Peak PWM OUT Current, Source or Sink		0.5	A
P <sub>D</sub>	Power Dissipation T <sub>A</sub> < 50°C		800	mW
Θ <sub>JA</sub>	Thermal Resistance (Junction-to-Air)	DIP	80.80	°C/W
		SOP	104.10	
Θ <sub>JC</sub>	Thermal Resistance (Junction-to-Case)	DIP	35.38	°C/W
		SOP	40.41	
T <sub>J</sub>	Operating Junction Temperature	-40	+125	°C
T <sub>STG</sub>	Storage Temperature Range	-55	+150	°C
T <sub>L</sub>	Lead Temperature(Soldering)		+260	°C
ESD	Electrostatic Discharge Capability	Human Body Model	5.0	kV
		Charged Device Model	1.5	

### Notes:

- All voltage values, except differential voltage, are given with respect to GND pin.
- Stresses beyond those listed under Absolute Maximum Ratings may cause permanent damage to the device.

## Recommended Operating Conditions

The Recommended Operating Conditions table defines the conditions for actual device operation. Recommended operating conditions are specified to ensure optimal performance to the datasheet specifications. Fairchild does not recommend exceeding them or designing to Absolute Maximum Ratings.

Symbol	Parameter	Min.	Typ.	Max.	Unit
T <sub>A</sub>	Operating Ambient Temperature	-40		+105	°C

## Electrical Characteristics

Unless otherwise noted,  $V_{DD}=15\text{ V}$ ,  $T_A=25^\circ\text{C}$ ,  $T_A=T_J$ ,  $R_T=6.8\text{ k}\Omega$ , and  $C_T=1000\text{ pF}$ .

Symbol	Parameter	Conditions	Min.	Typ.	Max.	Unit
<b>V<sub>DD</sub> Section</b>						
$V_{DD-OP}$	Continuously Operating Voltage				26	V
$I_{DD-ST}$	Startup Current	$V_{DD}=V_{TH-ON}-0.1\text{ V}$ ; OPFC OPWM Open		30	80	$\mu\text{A}$
$I_{DD-OP}$	Operating Current	$V_{DD}=13\text{ V}$ ; OPFC OPWM Open	2.0	2.6	5.0	mA
$V_{TH-ON}$	Turn-on Threshold Voltage		10	11	12	V
$\Delta V_{TH}$	Hysteresis		1.3		1.9	V
$V_{DD-OVP}$	$V_{DD}$ OVP		27	28	29	V
$\Delta V_{DD-OVP}$	$V_{DD}$ OVP Hysteresis			1		V
<b>Oscillator</b>						
$f_{OSC-RT/CT}$	RT/CT Frequency	$R_T=6.8\text{ k}\Omega$ , $C_T=1000\text{ pF}$	240	256	268	kHz
$f_{OSC}$	PFC & PWM Frequency	$R_T=6.8\text{ k}\Omega$ , $C_T=1000\text{ pF}$	60	64	67	kHz
	PWM Frequency		120	128	134	
$f_{DV}$	Voltage Stability <sup>(3)</sup>	$11\text{ V} \leq V_{DD} \leq 22\text{ V}$			2	%
$f_{DT}$	Temperature Stability <sup>(3)</sup>	$-40^\circ\text{C} \sim +105^\circ\text{C}$			2	%
$f_{TV}$	Total Variation (PFC & PWM) <sup>(3)</sup>	Line, Temperature	58		70	kHz
$f_{RV}$	Ramp Voltage	Valley to Peak		2.8		V
$I_{OSC-DIS}$	Discharge Current	$V_{RAMP}=0\text{V}$ , $V_{RT/CT}=2.5\text{ V}$	6.5		15.0	mA
$f_{RANGE}$	Frequency Range		50		75	kHz
$t_{PFC-DEAD}$	PFC Dead Time	$R_T=6.8\text{ k}\Omega$ , $C_T=1000\text{ pF}$	400	600	800	ns
<b>V<sub>REF</sub></b>						
$V_{VREF}$	Reference Voltage	$I_{REF}=0\text{ mA}$ , $C_{REF}=0.1\text{ }\mu\text{F}$	7.4	7.5	7.6	V
$\Delta V_{VREF1}$	Load Regulation of Reference Voltage	$C_{REF}=0.1\text{ }\mu\text{F}$ , $I_{REF}=0\text{ mA}$ to $3.5\text{ mA}$ $V_{DD}=14\text{ V}$ , Rise/Fall Time $> 20\text{ }\mu\text{s}$		30	50	mV
$\Delta V_{VREF2}$	Line Regulation of Reference Voltage	$C_{REF}=0.1\text{ }\mu\text{F}$ , $V_{DD}=11\text{ V}$ to $22\text{ V}$			25	mV
$\Delta V_{VREF-DT}$	Temperature Stability <sup>(3)</sup>	$-40^\circ\text{C} \sim +105^\circ\text{C}$		0.4	0.5	%
$\Delta V_{VREF-TV}$	Total Variation <sup>(3)</sup>	Line, Load, Temp	7.35		7.65	V
$\Delta V_{VREF-LS}$	Long-Term Stability <sup>(3)</sup>	$T_J=125^\circ\text{C}$ , $0 \sim 1000\text{ HRs}$	5		25	mV
$I_{REF-MAX}$	Maximum Current	$V_{VREF} > 7.35\text{ V}$	5			mA
<b>PFC OVP Comparator</b>						
$V_{PFC-OVP}$	Over-Voltage Protection		2.70	2.75	2.80	V
$\Delta V_{PFC-OVP}$	PFC OVP Hysteresis		200	250	300	mV
<b>Low-Power Detect Comparator</b>						
$V_{VEAOFF}$	VEA Voltage OFF OPFC		0.2	0.3	0.4	V
<b>V<sub>IN</sub> OK Comparator</b>						
$V_{RD-FBPFC}$	Voltage Level on FBPFC to Enable OPWM During Startup		2.3	2.4	2.5	V
$\Delta V_{RD-FBPFC}$	Hysteresis		1.15	1.25	1.35	V

Continued on the following page...



**Electrical Characteristics** (Continued)Unless otherwise noted,  $V_{DD}=15\text{ V}$ ,  $T_A=25^\circ\text{C}$ ,  $T_A=T_J$ ,  $R_T=6.8\text{ k}\Omega$ , and  $C_T=1000\text{ pF}$ .

Symbol	Parameter	Conditions	Min.	Typ.	Max.	Unit
<b>Voltage Error Amplifier</b>						
$V_{REF}$	Reference Voltage		2.45	2.50	2.55	V
$A_V$	Open-Loop Gain <sup>(3)</sup>		35	42		dB
$G_{m_V}$	Transconductance	$V_{NONINV}=V_{INV}$ , $V_{VEA}=3.75\text{ V}$	50	70	90	umho
$I_{FBPFC-L}$	Maximum Source Current	$V_{FBPFC}=2\text{ V}$ , $V_{VEA}=1.5\text{ V}$	40	50		$\mu\text{A}$
$I_{FBPFC-H}$	Maximum Sink Current	$V_{FBPFC}=3\text{ V}$ , $V_{VEA}=6\text{ V}$		-50	-40	$\mu\text{A}$
$I_{BS}$	Input Bias Current		-1		1	$\mu\text{A}$
$V_{VEA-H}$	Output High Voltage on $V_{VEA}$		5.8	6.0		V
$V_{VEA-L}$	Output Low Voltage on $V_{VEA}$			0.1	0.4	V
<b>Current Error Amplifier</b>						
$G_{m_I}$	Transconductance	$V_{NONINV}=V_{INV}$ , $V_{IEA}=3.75\text{ V}$	78	88	100	umho
$V_{OFFSET}$	Input Offset Voltage	$V_{VEA}=0\text{ V}$ , IAC Open	-10		10	mV
$V_{IEA-H}$	Output High Voltage		6.8	7.4	8.0	V
$V_{IEA-L}$	Output Low Voltage			0.1	0.4	V
$I_L$	Source Current	$V_{ISENSE}=-0.6\text{ V}$ , $V_{IEA}=1.5\text{ V}$	35	50		$\mu\text{A}$
$I_H$	Sink Current	$V_{ISENSE}=+0.6\text{ V}$ , $V_{IEA}=4.0\text{ V}$		-50	-35	$\mu\text{A}$
$A_I^{(3)}$	Open-Loop Gain		40	50		dB
<b>TriFault Detect™</b>						
$t_{FBPFC\_OPEN}$	Time to FBPFC Open	$V_{FBPFC}=V_{PFC-UVP}$ to FBPFC OPEN, 470 pF from FBPFC to GND		2	4	ms
$V_{PFC-UVP}$	PFC Feedback Under-Voltage Protection		0.4	0.5	0.6	V
<b>Gain Modulator</b>						
$I_{AC}$	Input for AC Current <sup>(3)</sup>	Multiplier Linear Range	0		100	$\mu\text{A}$
GAIN	GAIN Modulator <sup>(4)</sup>	$I_{AC}=17.67\text{ }\mu\text{A}$ , $V_{RMS}=1.080\text{ V}$ $V_{FBPFC}=2.25\text{ V}$	7.500	9.000	10.500	
		$I_{AC}=20.00\text{ }\mu\text{A}$ , $V_{RMS}=1.224\text{ V}$ $V_{FBPFC}=2.25\text{ V}$	6.367	7.004	7.704	
		$I_{AC}=25.69\text{ }\mu\text{A}$ , $V_{RMS}=1.585\text{ V}$ $V_{FBPFC}=2.25\text{ V}$	3.801	4.182	4.600	
		$I_{AC}=51.62\text{ }\mu\text{A}$ , $V_{RMS}=3.169\text{ V}$ $V_{FBPFC}=2.25\text{ V}$	0.950	1.045	1.149	
		$I_{AC}=62.23\text{ }\mu\text{A}$ , $V_{RMS}=3.803\text{ V}$ $V_{FBPFC}=2.25\text{ V}$	0.660	0.726	0.798	
BW	Bandwidth <sup>(3)</sup>	$I_{AC}=40\text{ }\mu\text{A}$		2		kHz
$V_{O(gm)}$	Output Voltage= $5.7\text{ k}\Omega \times (I_{SENSE}-I_{OFFSET})$	$I_{AC}=20\text{ }\mu\text{A}$ , $V_{RMS}=1.224\text{ V}$ $V_{FBPFC}=2.25\text{ V}$	0.710	0.798	0.885	V
<b>PFC <math>I_{LIMIT}</math> Comparator</b>						
$V_{PFC-ILIMIT}$	Peak Current Limit Threshold Voltage, Cycle-by-Cycle Limit		-1.35	-1.20	-1.05	V
$\Delta V_{PK}$	PFC $I_{LIMIT}$ -Gain Modulator Output	$I_{AC}=17.67\text{ }\mu\text{A}$ , $V_{RMS}=1.08\text{ V}$ $V_{FBPFC}=2.25\text{ V}$	200			mV

Continued on the following page...

**Electrical Characteristics** (Continued)Unless otherwise noted,  $V_{DD}=15\text{ V}$ ,  $T_A=25^\circ\text{C}$ ,  $T_A=T_J$ ,  $R_T=6.8\text{ k}\Omega$ , and  $C_T=1000\text{ pF}$ .

Symbol	Parameter	Conditions	Min.	Typ.	Max.	Unit
<b>PFC Output Driver</b>						
$V_{\text{GATE-CLAMP}}$	Gate Output Clamping Voltage	$V_{DD}=22\text{ V}$	13	15	17	V
$V_{\text{GATE-L}}$	Gate Low Voltage	$V_{DD}=15\text{ V}$ , $I_O=100\text{ mA}$			1.5	V
$V_{\text{GATE-H}}$	Gate High Voltage	$V_{DD}=13\text{ V}$ , $I_O=100\text{ mA}$	8			V
$t_R$	Gate Rising Time	$V_{DD}=15\text{ V}$ , $C_L=4.7\text{ nF}$ , $O/P=2\text{ V to }9\text{ V}$	40	70	120	ns
$t_F$	Gate Falling Time	$V_{DD}=15\text{ V}$ ; $C_L=4.7\text{ nF}$ , $O/P=9\text{ V to }2\text{ V}$	40	60	110	ns
$D_{\text{PFC-MAX}}$	Maximum Duty Cycle	$V_{\text{IEA}}<1.2\text{ V}$	94	97		%
$D_{\text{PFC-MIN}}$	Minimum Duty Cycle	$V_{\text{IEA}}>4.5\text{ V}$			0	%
<b>Brownout</b>						
$V_{\text{RMS-UVL}}$	$V_{\text{RMS}}$ Threshold Low	When $V_{\text{RMS}}=1.05\text{ V}$ at $75\text{ }V_{\text{RMS}}$	1.03	1.05	1.08	V
$V_{\text{RMS-UVH}}$	$V_{\text{RMS}}$ Threshold High	When $V_{\text{RMS}}=1.9\text{ V}$ at $85\cdot 1.414$	1.88	1.90	1.94	V
$V_{\text{RMS-UVP}}$	Hysteresis		750	850	950	mV
$t_{\text{UVP}}$	Under Voltage Protection Debounce Time		850	1000	1150	ms
<b>Soft Start</b>						
$V_{\text{SS-MAX}}$	Maximum Voltage	$V_{DD}=15\text{ V}$	9.5	10.0	10.5	V
$I_{\text{SS}}$	Soft-Start Current			10		$\mu\text{A}$
<b>PWM <math>I_{\text{LIMIT}}</math> Comparator</b>						
$V_{\text{PWM-ILIMIT}}$	Threshold Voltage		0.95	1.00	1.05	V
$t_{\text{PD}}$	Propagation Delay to Output			250		ns
$t_{\text{PWM-BNK}}$	Leading-Edge Blanking Time		170	250	350	ns
<b>Range (FAN4801S/02S)</b>						
$V_{\text{VRMS-L}}$	RMS AC Voltage Low	When $V_{\text{VRMS}}=1.95\text{ V}$ at $132\text{ }V_{\text{RMS}}$	1.90	1.95	2.00	V
$V_{\text{VRMS-H}}$	RMS AC Voltage High	When $V_{\text{VRMS}}=2.45\text{ V}$ at $150\text{ }V_{\text{RMS}}$	2.40	2.45	2.50	V
$V_{\text{VEA-L}}$	VEA LOW	When $V_{\text{VEA}}=1.95\text{ V}$ at 30% Loading	1.90	1.95	2.00	V
$V_{\text{VEA-H}}$	VEA HIGH	When $V_{\text{VEA}}=2.45\text{ V}$ at 40% Loading	2.40	2.45	2.50	V
$I_{\text{TC}}$	Source Current from FBPF		18	20	22	$\mu\text{A}$
<b>PWM Output Driver</b>						
$V_{\text{GATE-CLAMP}}$	Gate Output Clamping Voltage	$V_{DD}=22\text{ V}$	18	19	20	V
$V_{\text{GATE-L}}$	Gate Low Voltage	$V_{DD}=15\text{ V}$ , $I_O=100\text{ mA}$			1.5	V
$V_{\text{GATE-H}}$	Gate High Voltage	$V_{DD}=13\text{ V}$ , $I_O=100\text{ mA}$	8			V
$t_R$	Gate Rising Time	$V_{DD}=15\text{ V}$ , $C_L=4.7\text{ nF}$	30	60	120	ns
$t_F$	Gate Falling Time	$V_{DD}=15\text{ V}$ , $C_L=4.7\text{ nF}$	30	50	110	ns
$D_{\text{PWM-MAX}}$	Maximum Duty Cycle		49.0	49.5	50.0	%
$V_{\text{PWM-LS}}$	PWM Comparator Level Shift		1.3	1.5	1.8	V

**Notes:**

- This parameter, although guaranteed by design, is not 100% production tested.
- This GAIN is the maximum gain of modulation with a given  $V_{\text{RMS}}$  voltage when  $V_{\text{VEA}}$  is saturated to HIGH.

## Typical Characteristics

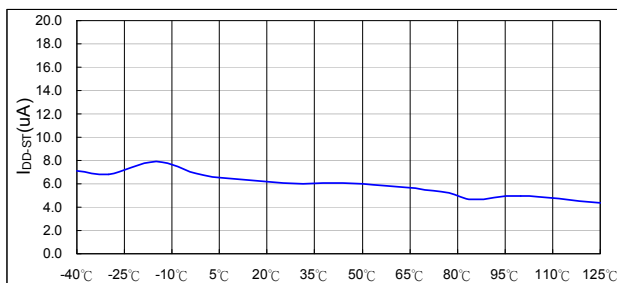

Figure 8.  $I_{DD-ST}$  vs. Temperature

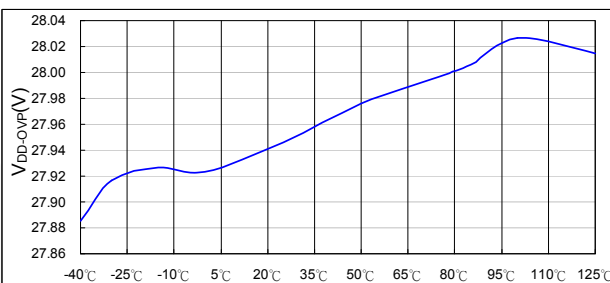

Figure 9.  $V_{DD-OVP}$  vs. Temperature

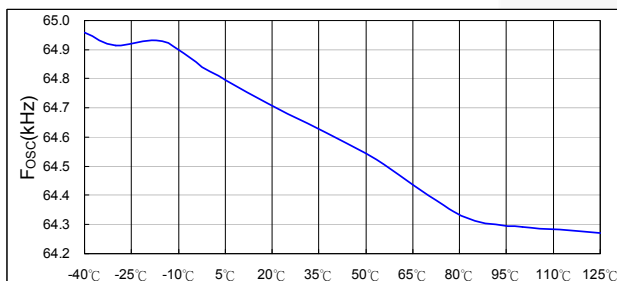

Figure 10.  $f_{osc}$  vs. Temperature

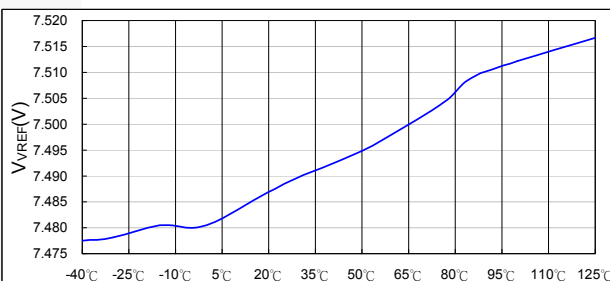

Figure 11.  $V_{VREF}$  vs. Temperature

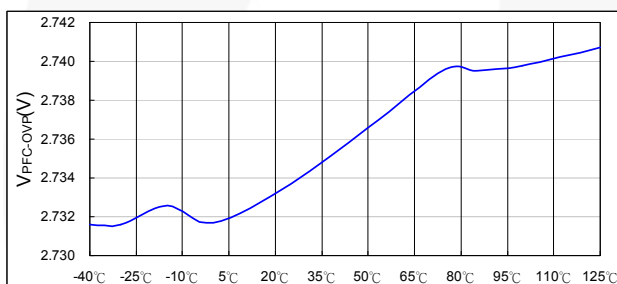

Figure 12.  $V_{PFC-OVP}$  vs. Temperature

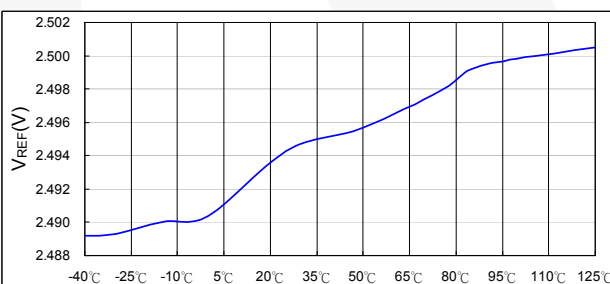

Figure 13.  $V_{REF}$  vs. Temperature

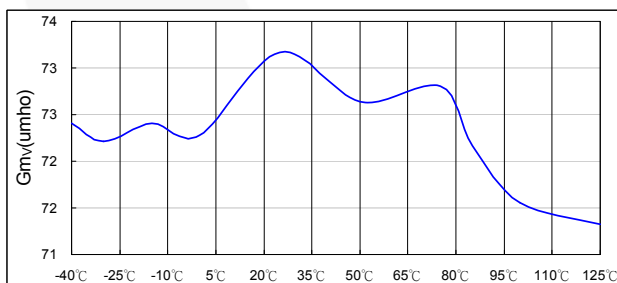

Figure 14.  $Gm_V$  vs. Temperature

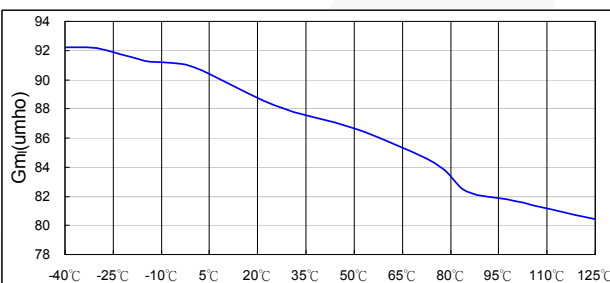

Figure 15.  $Gm_I$  vs. Temperature

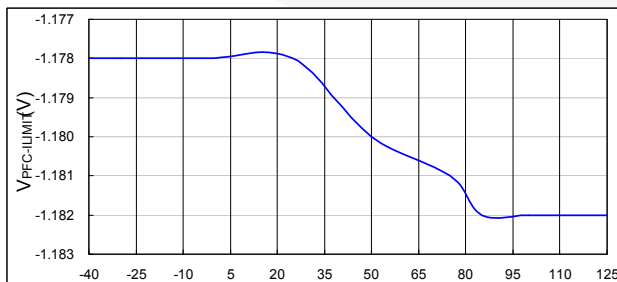

Figure 16.  $V_{PFC-ILIMIT}$  vs. Temperature

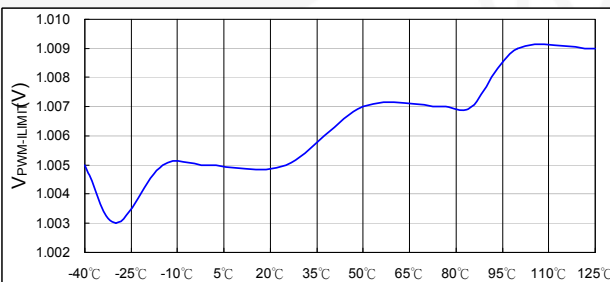

Figure 17.  $V_{PWM-ILIMIT}$  vs. Temperature

## Typical Characteristics

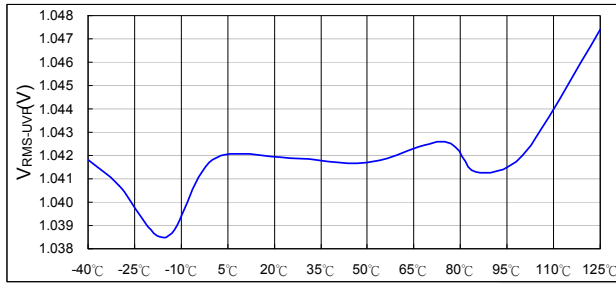

Figure 18.  $V_{RMS-UVF}$  vs. Temperature

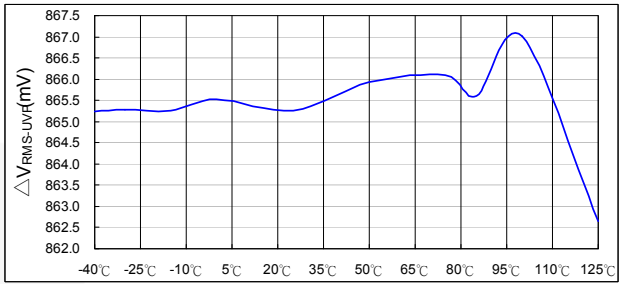

Figure 19.  $\Delta V_{RMS-UVF}$  vs. Temperature

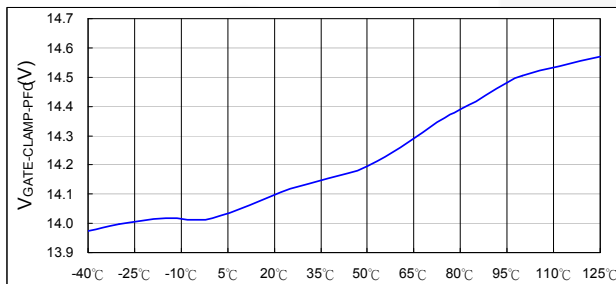

Figure 20.  $V_{GATE-CLAMP-PFC}$  vs. Temperature

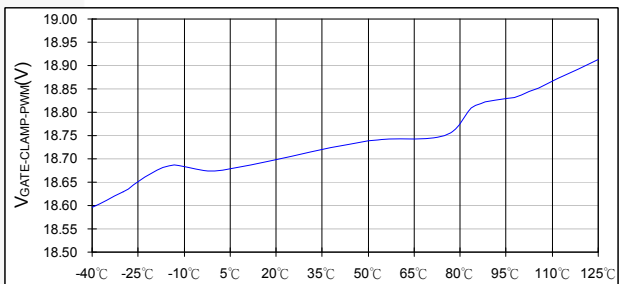

Figure 21.  $V_{GATE-CLAMP-PWM}$  vs. Temperature

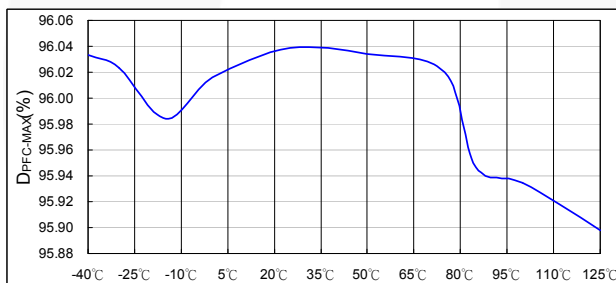

Figure 22.  $D_{PFC-MAX}$  vs. Temperature

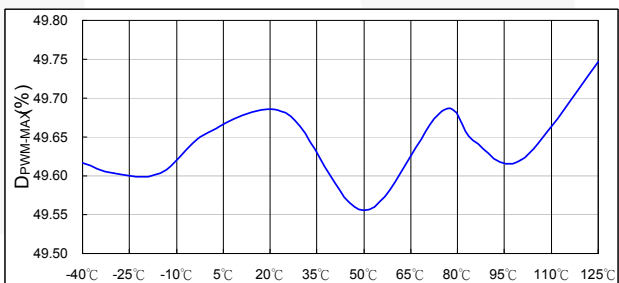

Figure 23.  $D_{PWM-MAX}$  vs. Temperature

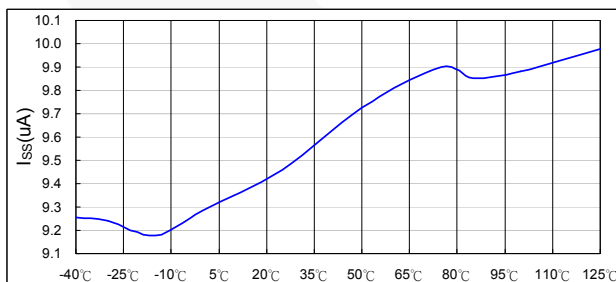

Figure 24.  $I_{SS}$  vs. Temperature

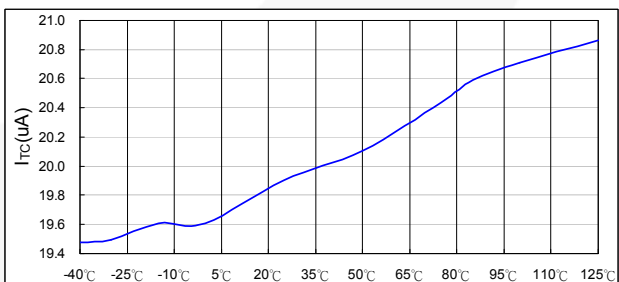

Figure 25.  $I_{TC}$  vs. Temperature

## Functional Description

The FAN4800AS/CS/01S/02S consist of an average current controlled, continuous-boost, Power Factor Correction (PFC) front-end and a synchronized Pulse Width Modulator (PWM) back-end. The PWM can be used in current or voltage mode. In voltage mode, feedforward from the PFC output bus can help improve the line regulation of PWM. In either mode, the PWM stage uses conventional trailing-edge, duty-cycle modulation. This proprietary leading / trailing edge modulation results in a higher usable PFC error amplifier bandwidth and can significantly reduce the size of the PFC DC bus capacitor.

The synchronization of the PWM with the PFC simplifies the PWM compensation due to the controlled ripple on the PFC output capacitor (the PWM input capacitor).

In addition to power factor correction, a number of protection features are built into this series. They include soft-start, PFC over-voltage protection, peak current limiting, brownout protection, duty cycle limiting, and under-voltage lockout (UVLO).

### Gain Modulator

The gain modulator is the heart of the PFC, as the circuit block controls the response of the current loop to line voltage waveform and frequency, RMS line voltage, and PFC output voltages. There are three inputs to the gain modulator:

1. A current representing the instantaneous input voltage (amplitude and wave shape) to the PFC. The rectified AC input sine wave is converted to a proportional current via a resistor and is fed into the gain modulator at IAC. Sampling current in this way minimizes ground noise, required in high-power, switching-power conversion environments. The gain modulator responds linearly to this current.
2. A voltage proportional to the long-term RMS AC line voltage, derived from the rectified line voltage after scaling and filtering. This signal is presented to the gain modulator at VRMS. The output of the gain modulator is inversely proportional to  $V_{RMS}$  (except at unusually low values of  $V_{RMS}$ , where special gain contouring takes over to limit power dissipation of the circuit components under brownout conditions).
3. The output of the voltage error amplifier,  $V_{EA}$ . The gain modulator responds linearly to variations in  $V_{EA}$ .

The output of the gain modulator is a current signal, in the form of a full wave rectified sinusoid at twice the line frequency. This current is applied to the virtual ground (negative) input of the current error amplifier. In this way, the gain modulator forms the reference for the current error loop and ultimately controls the instantaneous current draw of the PFC from the power line. The general form of the output of the gain modulator is:

$$I_{GAINMOD} = \frac{I_{AC} \times (V_{EA} - 0.7)}{VRMS^2} \times K \quad (1)$$

Note that the output current of the gain modulator is limited around 159  $\mu$ A and the maximum output voltage of the gain modulator is limited to 159  $\mu$ A x 5.7 k=0.906 V. This 0.906 V also determines the maximum input power. However,  $I_{GAINMOD}$  cannot be measured directly from ISENSE.  $I_{SENSE}=I_{GAINMOD} - I_{OFFSET}$  and  $I_{OFFSET}$  can only be measured when  $V_{VEA}$  is less than 0.5 V and  $I_{GAINMOD}$  is 0 A. Typical  $I_{OFFSET}$  is around 31  $\mu$ A ~ 48  $\mu$ A.

### Selecting $R_{AC}$ for the IAC Pin

The IAC pin is the input of the gain modulator and also a current mirror input that requires current input. Selecting a proper resistor,  $R_{AC}$ , provides a good sine wave current derived from the line voltage and helps program the maximum input power and minimum input line voltage.  $R_{AC}=V_{IN} \text{ peak} \times 56 \text{ k}\Omega$ . For example, if the minimum line voltage is 75  $V_{AC}$ , the  $R_{AC}=75 \times 1.414 \times 56 \text{ k}\Omega=6 \text{ M}\Omega$ .

### Current Amplifier Error, IEA

The current error amplifier's output controls the PFC duty cycle to keep the average current through the boost inductor a linear function of the line voltage. At the inverting input to the current error amplifier, the output current of the gain modulator is summed with a current, which results in a negative voltage being impressed upon the ISENSE pin.

The negative voltage on ISENSE represents the sum of all currents flowing in the PFC circuit and is typically derived from a current-sense resistor in series with the negative terminal of the input bridge rectifier.

The inverting input of the current error amplifier is a virtual ground. Given this fact, and the arrangement of the duty cycle modulator polarities internal to the PFC, an increase in positive current from the gain modulator causes the output stage to increase its duty cycle until the voltage on ISENSE is adequately negative to cancel this increased current. Similarly, if the gain modulator's output decreases, the output duty cycle decreases to achieve a less negative voltage on the ISENSE pin.

### PFC Cycle-By-Cycle Current Limiter

In addition to being a part of the current feedback loop, the ISENSE pin is a direct input to the cycle-by-cycle current limiter for the PFC section. If the input voltage at this pin is less than -1.15 V, the output of the PFC is disabled until the protection flip-flop is reset by the clock pulse at the start of the next PFC power cycle.



## Two-Level PFC Function

To improve the efficiency, the system can reduce PFC switching loss at low line and light load by reducing the PFC output voltage. The two-level PFC output of the FAN4801S/02S can be programmable.

As Figure 27 shows, FAN4801S/02S detect the voltage of VEA and VRMS pins to determine if the system operates low line and light load. At the second-level PFC, there is a current of 20  $\mu$ A through  $R_{F2}$  from the FBPFC pin. The second-level PFC output voltage can be calculated as.

$$\text{Output} \cong \frac{R_{F1} + R_{F2}}{R_{F2}} \times (2.5V - 20\mu A \times R_{F2}) \quad (3)$$

For example, if the second-level PFC output voltage is expected as 300 V and normal voltage is 387 V, according to the equation,  $R_{F2}$  is 28 k $\Omega$   $R_{F1}$  is 4.3 M $\Omega$ .

The programmable range of second level PFC output voltage is 340 V ~ 300 V.

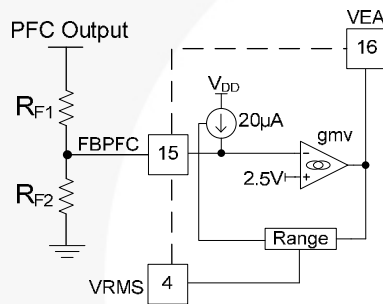

Figure 27. Two-Level PFC Scheme

## Oscillator (RT/CT)

The oscillator frequency is determined by the values of  $R_T$  and  $C_T$ , which determine the ramp and off-time of the oscillator output clock:

$$f_{RT/CT} = \frac{1}{t_{RT/CT} + t_{DEAD}} \quad (4)$$

The dead time of the oscillator is derived from the following equation:

$$t_{RT/CT} = C_T \times R_T \times \ln\left(\frac{V_{REF} - 1}{V_{REF} - 3.8}\right) \quad (5)$$

at  $V_{REF}=7.5$  V and  $t_{RT/CT}=C_T \times R_T \times 0.56$ .

The dead time of the oscillator is determined using:

$$t_{DEAD} = \frac{2.8V}{7.78mA} \times C_T = 360 \times C_T \quad (6)$$

The dead time is so small ( $t_{RT/CT} \gg t_{DEAD}$ ) that the operating frequency can typically be approximated by:

$$f_{RT/CT} \cong \frac{1}{t_{RT/CT}} \quad (7)$$

## Pulse Width Modulator (PWM)

The operation of the PWM section is straightforward, but there are several points that should be noted. Foremost among these is the inherent synchronization of PWM with the PFC section of the device, from which it also derives its basic timing. The PWM is capable of current-mode or voltage-mode operation. In current-mode applications, the PWM ramp (RAMP) is usually derived directly from a current-sensing resistor or current transformer in the primary side of the output stage. It is thereby representative of the current flowing in the converter's output stage.  $I_{LIMIT}$ , which provides cycle-by-cycle current limiting, is typically connected to RAMP in such applications. For voltage-mode operation and certain specialized applications, RAMP can be connected to a separate RC timing network to generate a voltage ramp against which FBPWM is compared. Under these conditions, the use of voltage feedforward from the PFC bus can assist in line regulation accuracy and response. As in current-mode operation, the  $I_{LIMIT}$  input is used for output stage over-current protection. No voltage error amplifier is included in the PWM stage, as this function is generally performed on the output side of the PWM's isolation boundary. To facilitate the design of opto-coupler feedback circuitry, an offset has been built into the PWM's RAMP input that allows FBPWM to command a 0% duty cycle for input voltages below typical 1.5 V.

## PWM Cycle-by-Cycle Current Limiter

The  $I_{LIMIT}$  pin is a direct input to the cycle-by-cycle current limiter for the PWM section. Should the input voltage at this pin exceed 1 V, the output flip-flop is reset by the clock pulse at the start of the next PWM power cycle. When the  $I_{LIMIT}$  triggers the cycle-by-cycle bi-cycle current, it limits the PWM duty cycle mode and the power dissipation is reduced during the dead-short condition.

## $V_{IN}$ OK Comparator

The  $V_{IN}$  OK comparator monitors the DC output of the PFC and inhibits the PWM if the voltage on FBPFC is less than its nominal 2.4 V. Once the voltage reaches 2.4 V, which corresponds to the PFC output capacitor being charged to its rated boost voltage, soft-start begins.

## PWM Soft-Start (SS)

PWM startup is controlled by selection of the external capacitor at soft-start. A current source of 10  $\mu$ A supplies the charging current for the capacitor and startup of the PWM begins at 1.5 V.

### PWM Control (RAMP)

When the PWM section is used in current mode, RAMP is generally used as the sampling point for a voltage, representing the current in the primary of the PWM's output transformer. The voltage is derived either from a current-sensing resistor or a current transformer. In voltage mode, RAMP is the input for a ramp voltage generated by a second set of timing components ( $R_{RAMP}$ ,  $C_{RAMP}$ ) that have a minimum value of 0V and a peak value of approximately 6V. In voltage mode, feedforward from the PFC output bus is an excellent way to derive the timing ramp for the PWM stage.

### Generating $V_{DD}$

After turning on the FAN4800AS/CS/01S/02S at 11 V, the operating voltage can vary from 9.3 V to 28 V. The threshold voltage of the  $V_{DD}$  OVP comparator is 28 V and its hysteresis is 1 V. When  $V_{DD}$  reaches 28 V, OPFC is LOW and the PWM section is not disturbed. There are two ways to generate  $V_{DD}$ : use auxiliary power supply around 15 V or use bootstrap winding to self-bias the FAN4800AS/CS/01S/02S system. The bootstrap winding can be taped from the PFC boost choke or the transformer of the DC-to-DC stage.

### Leading/Trailing Edge Modulation

Conventional PWM techniques employ trailing-edge modulation, in which the switch turns on right after the trailing edge of the system clock. The error amplifier output is then compared with the modulating ramp up. The effective duty cycle of the trailing-edge modulation is determined during the on-time of the switch.

In the case of leading-edge modulation, the switch is turned off exactly at the leading edge of the system clock. When the modulating ramp reaches the level of the error amplifier output voltage, the switch is turned on. The effective duty-cycle of the leading-edge modulation is determined during off-time of the switch.



## Physical Dimensions

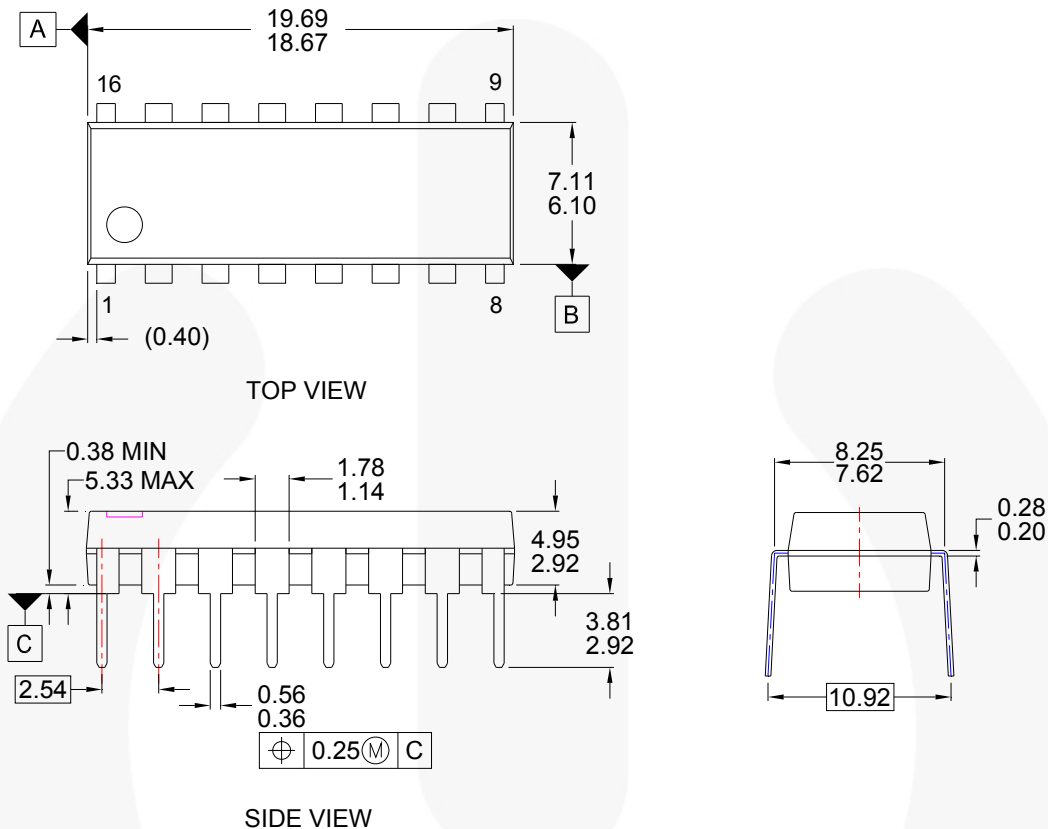

NOTES: UNLESS OTHERWISE SPECIFIED

- A) THIS PACKAGE CONFORMS TO JEDEC MS-001 VARIATION BB
- B) ALL DIMENSIONS ARE IN MILLIMETERS.
- C) DIMENSIONS ARE EXCLUSIVE OF BURRS, MOLD FLASH, AND TIE BAR PROTRUSIONS
- D) CONFORMS TO ASME Y14.5M-1994
- E) DRAWING FILE NAME: N16EREV2

**Figure 28. 16-Pin, Dual In-Line Package (DIP), JEDEC MS-001, .300" Wide**

Package drawings are provided as a service to customers considering Fairchild components. Drawings may change in any manner without notice. Please note the revision and/or date on the drawing and contact a Fairchild Semiconductor representative to verify or obtain the most recent revision. Package specifications do not expand the terms of Fairchild's worldwide terms and conditions, specifically the warranty therein, which covers Fairchild products.

Always visit Fairchild Semiconductor's online packaging area for the most recent package drawings:  
<http://www.fairchildsemi.com/packaging/>.

### Physical Dimensions

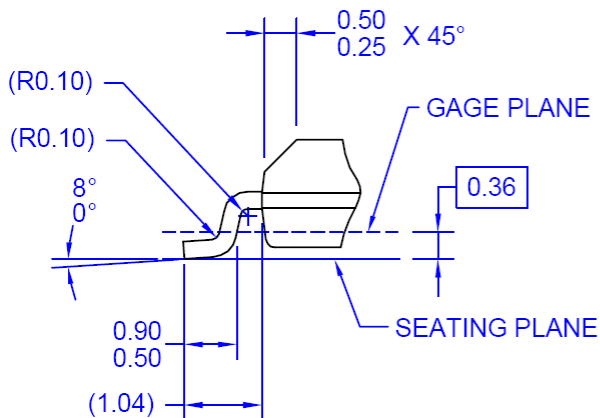
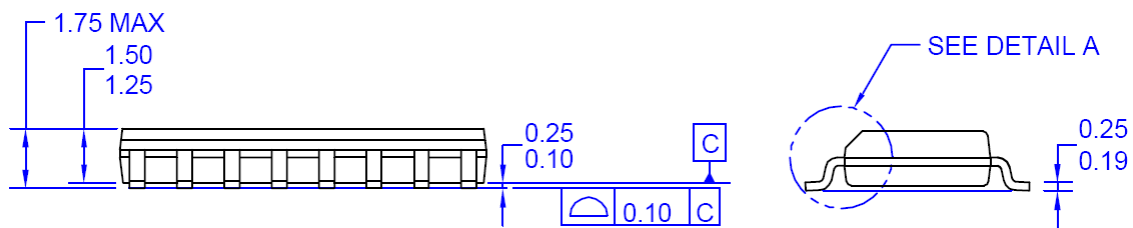
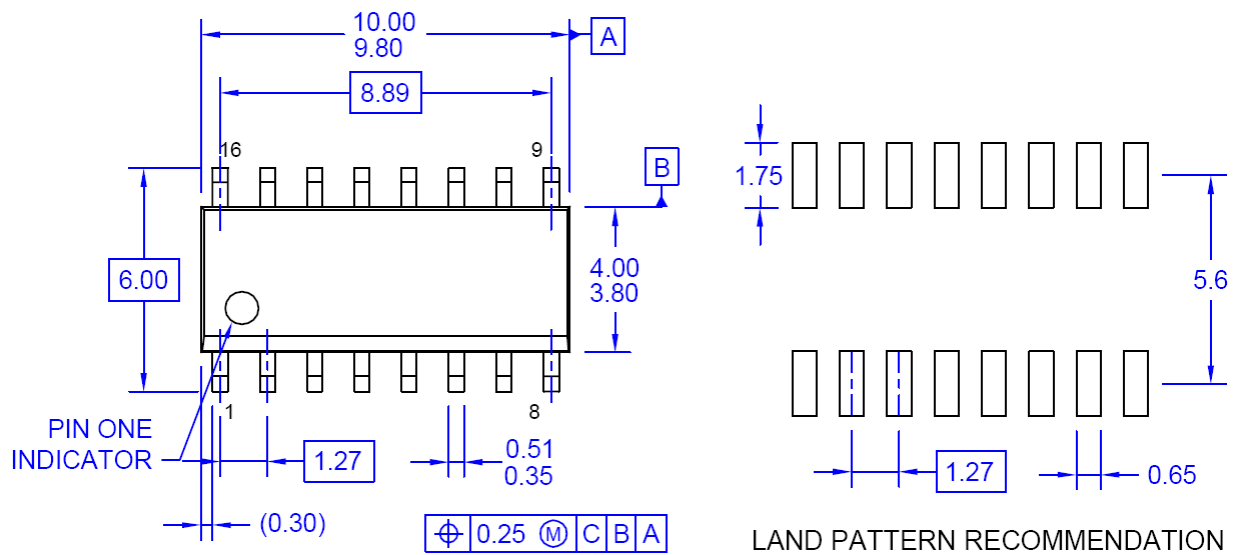

NOTES: UNLESS OTHERWISE SPECIFIED

- A) THIS PACKAGE CONFORMS TO JEDEC MS-012, VARIATION AC, ISSUE C.
- B) ALL DIMENSIONS ARE IN MILLIMETERS.
- C) DIMENSIONS ARE EXCLUSIVE OF BURRS, MOLD FLASH AND TIE BAR PROTRUSIONS
- D) CONFORMS TO ASME Y14.5M-1994
- E) LANDPATTERN STANDARD: SOIC127P600X175-16AM
- F) DRAWING FILE NAME: M16AREV12.

**Figure 29. 16-Pin Small Outline Package (SOIC), JEDEC MS-012, .150", Narrow Body**

Package drawings are provided as a service to customers considering Fairchild components. Drawings may change in any manner without notice. Please note the revision and/or date on the drawing and contact a Fairchild Semiconductor representative to verify or obtain the most recent revision. Package specifications do not expand the terms of Fairchild's worldwide terms and conditions, specifically the warranty therein, which covers Fairchild products.

Always visit Fairchild Semiconductor's online packaging area for the most recent package drawings:  
<http://www.fairchildsemi.com/packaging/>.



**TRADEMARKS**

The following includes registered and unregistered trademarks and service marks, owned by Fairchild Semiconductor and/or its global subsidiaries, and is not intended to be an exhaustive list of all such trademarks:

- |                          |  |                                       |                  |
|--------------------------|--|---------------------------------------|------------------|
| AccuPower™               | F-PFST™  |                                       | Sync-Lock™       |
| AX-CAP®*                 | FRFET®   |                                       | SYSTEM GENERAL®  |
| BitSiC™                  | Global Power Resource™                         | PowerTrench®                          | TinyBoost®       |
| Build it Now™            | GreenBridge™                                   | PowerXS™                              | TinyBuck®        |
| CorePLUS™                | Green FPS™                                     | Programmable Active Droop™            | TinyCalc™        |
| CorePOWER™               | Green FPS™ e-Series™                           | QFET®                                 | TinyLogic®       |
| CROSSVOLT™               | Gmax™  | QST™                                  | TINYOPTO™        |
| CTL™                     | GTO™   | Quiet Series™                         | TinyPower™       |
| Current Transfer Logic™  | IntelliMAX™                                    | RapidConfigure™                       | TinyPWM™         |
| DEUXPEED®                | ISOPLANAR™                                     |                                       | TinyWire™        |
| Dual Cool™               | Making Small Speakers Sound Louder and Better™ | Saving our world, 1mW/W/kW at a time™ | TransiC™         |
| EcoSPARK®                | MegaBuck™                                      | SignalWise™                           | TriFault Detect™ |
| EfficientMax™            | MICROCOUPLER™                                  | SmartMax™                             | TRUECURRENT®*    |
| ESBC™                    | MicroFET™                                      | SMART START™                          | µSerDes™         |
| Fairchild®               | MicroPak™                                      | Solutions for Your Success™           | SerDes™          |
| Fairchild Semiconductor® | MicroPak2™                                     | SPM®                                  | UHC™             |
| FACT Quiet Series™       | MillerDrive™                                   | STEALTH™                              | Ultra FRFET™     |
| FACT®                    | MotionMax™                                     | SuperFET®                             | UniFET™          |
| FAST®                    | mWSaver®                                       | SuperSOT™-3                           | VCC™             |
| FastvCore™               | OptoHIT™                                       | SuperSOT™-6                           | VisualMax™       |
| FETBench™                | OPTOLOGIC®                                     | SuperSOT™-8                           | VoltagePlus™     |
| FPS™                     | OPTOPLANAR®                                    | SupreMOS®                             | XS™              |
|                          |  | SyncFET™                              |                  |

\* Trademarks of System General Corporation, used under license by Fairchild Semiconductor.

**DISCLAIMER**

FAIRCHILD SEMICONDUCTOR RESERVES THE RIGHT TO MAKE CHANGES WITHOUT FURTHER NOTICE TO ANY PRODUCTS HEREIN TO IMPROVE RELIABILITY, FUNCTION, OR DESIGN. FAIRCHILD DOES NOT ASSUME ANY LIABILITY ARISING OUT OF THE APPLICATION OR USE OF ANY PRODUCT OR CIRCUIT DESCRIBED HEREIN; NEITHER DOES IT CONVEY ANY LICENSE UNDER ITS PATENT RIGHTS, NOR THE RIGHTS OF OTHERS. THESE SPECIFICATIONS DO NOT EXPAND THE TERMS OF FAIRCHILD'S WORLDWIDE TERMS AND CONDITIONS, SPECIFICALLY THE WARRANTY THEREIN, WHICH COVERS THESE PRODUCTS.

**LIFE SUPPORT POLICY**

FAIRCHILD'S PRODUCTS ARE NOT AUTHORIZED FOR USE AS CRITICAL COMPONENTS IN LIFE SUPPORT DEVICES OR SYSTEMS WITHOUT THE EXPRESS WRITTEN APPROVAL OF FAIRCHILD SEMICONDUCTOR CORPORATION.

As used herein:

1. Life support devices or systems are devices or systems which, (a) are intended for surgical implant into the body or (b) support or sustain life, and (c) whose failure to perform when properly used in accordance with instructions for use provided in the labeling, can be reasonably expected to result in a significant injury of the user.
2. A critical component in any component of a life support, device, or system whose failure to perform can be reasonably expected to cause the failure of the life support device or system, or to affect its safety or effectiveness.

**ANTI-COUNTERFEITING POLICY**

Fairchild Semiconductor Corporation's Anti-Counterfeiting Policy. Fairchild's Anti-Counterfeiting Policy is also stated on our external website, [www.fairchildsemi.com](http://www.fairchildsemi.com), under Sales Support.

Counterfeiting of semiconductor parts is a growing problem in the industry. All manufacturers of semiconductor products are experiencing counterfeiting of their parts. Customers who inadvertently purchase counterfeit parts experience many problems such as loss of brand reputation, substandard performance, failed applications, and increased cost of production and manufacturing delays. Fairchild is taking strong measures to protect ourselves and our customers from the proliferation of counterfeit parts. Fairchild strongly encourages customers to purchase Fairchild parts either directly from Fairchild or from Authorized Fairchild Distributors who are listed by country on our web page cited above. Products customers buy either from Fairchild directly or from Authorized Fairchild Distributors are genuine parts, have full traceability, meet Fairchild's quality standards for handling and storage and provide access to Fairchild's full range of up-to-date technical and product information. Fairchild and our Authorized Distributors will stand behind all warranties and will appropriately address any warranty issues that may arise. Fairchild will not provide any warranty coverage or other assistance for parts bought from Unauthorized Sources. Fairchild is committed to combat this global problem and encourage our customers to do their part in stopping this practice by buying direct or from authorized distributors.

**PRODUCT STATUS DEFINITIONS**

**Definition of Terms**

Datasheet Identification	Product Status	Definition
Advance Information	Formative / In Design	Datasheet contains the design specifications for product development. Specifications may change in any manner without notice.
Preliminary	First Production	Datasheet contains preliminary data; supplementary data will be published at a later date. Fairchild Semiconductor reserves the right to make changes at any time without notice to improve design.
No Identification Needed	Full Production	Datasheet contains final specifications. Fairchild Semiconductor reserves the right to make changes at any time without notice to improve the design.
Obsolete	Not In Production	Datasheet contains specifications on a product that is discontinued by Fairchild Semiconductor. The datasheet is for reference information only.

Rev. 166