

DESIGNED FOR USE WITH	RG-174/U OR EQUIVALENT
CABLE ENTRY DIAMETER	MINIMUM
CONTACT	.021
SLEEVE	.128
CLAMP NUT	.179

REVISIONS			
REV	DESCRIPTION	DATE	APPROVED
03 ₃	REVISED	1/30/97	

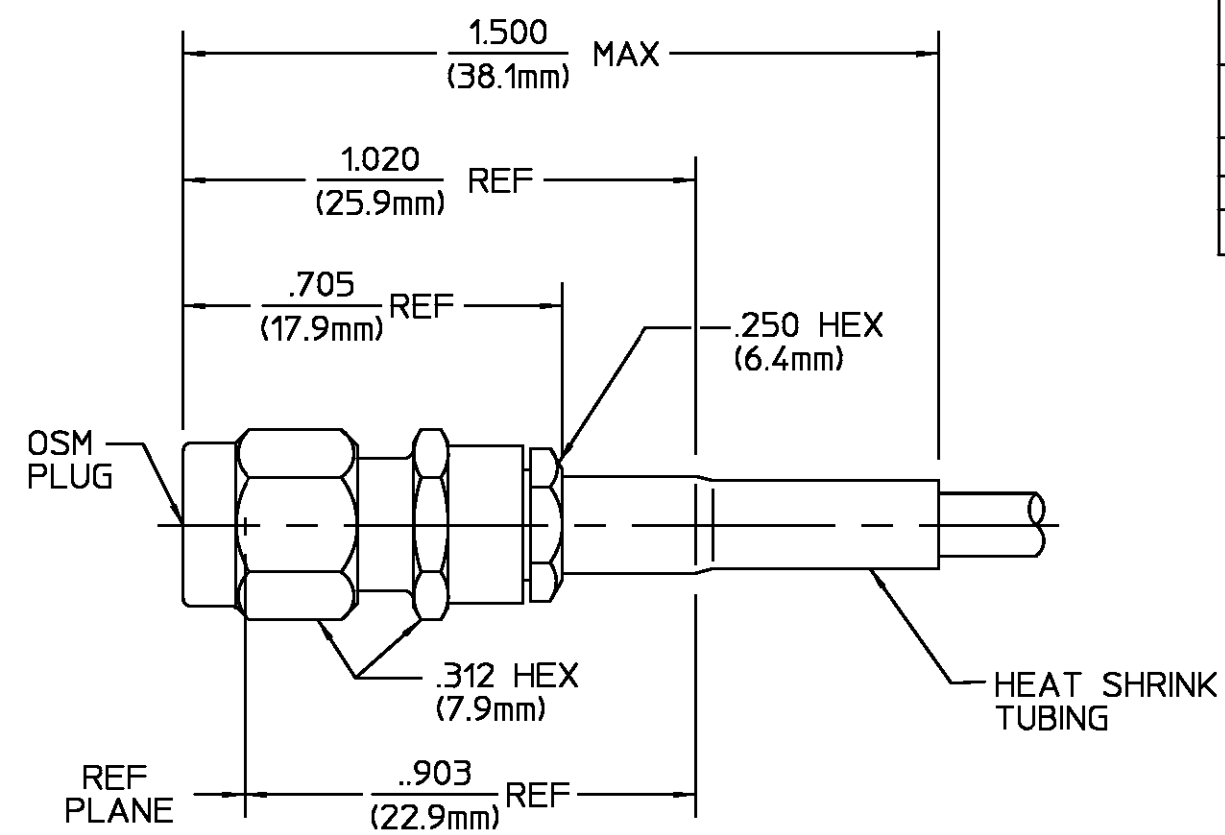

COMPONENT	MATERIAL	FINISH
HOUSING COUPLING NUT CLAMP NUT SLEEVE	STAINLESS STEEL PER ASTM-A484 AND ASTM- A582, TYPE 303	PASSIVATE PER QQ-P-35
DIELECTRIC	TFE FLUOROCARBON PER ASTM-D-1457	N/A
REAR DIELECTRIC	NYLON OR ZYTEL #101 PER MIL-M-20693A	N/A
CENTER CONTACT	BRASS PER ASTM-B-16, HALF HARD	GOLD PLATE PER MIL-G-45204
RETAINING RING	BERYLLIUM COPPER PER ASTM B 194, ALLOY C17200, CONDITION H	N/A
GASKET O-RING	SILICONE RUBBER PER ZZ-R-765	N/A
SHRINK TUBING	HEAT SHRINKABLE POLYOLEFIN COMPOUND MIL-I-23053/4	N/A
FERRULE	COPPER OR BRASS ALLOY ROCKWELL F65 MAXIMUM	GOLD PLATE PER MIL-G-45204

ELECTRICAL	MECHANICAL	ENVIRONMENTAL
Nominal Impedance (Ohms) <u>50</u>	Interface Dimensions MIL-STD-348A, Fig. 310.1	Temperature Rating <u>-65°C To +165°C</u>
Frequency Range (GHz) DC to <u>12.4</u>	Recommended Mating	Vibration MIL-STD-202, Method 204, Condition D
Volt Rating (VRMS MAX) @ Sea Level <u>250</u>	Torque <u>7-10 IN-LB</u>	Shock MIL-STD-202, Method 213, Condition I
VSWR <u>1.15±.02 f(GHz)</u>	Mating Characteristics:	Thermal Shock MIL-STD-202, Method 107, Condition C,
Insertion Loss (dB MAX) <u>.06√f(GHz)</u>	Insertion (MAX Lbs) <u>N/A</u>	Moisture Resistance MIL-STD-202, Method 106,
RF Leakage (dB MIN) <u>-60</u>	Withdrawal (MIN Oz) <u>N/A</u>	Corrosion - MIL-STD-202, Method 101, Condition B, 5% salt spray
Corona, 70,000 Ft (VRMS MIN) <u>190</u>	Force to Engage and Disengage (In-Lbs MAX) <u>2</u>	
Dielectric Withstanding Voltage (VRMS MIN) @ Sea Level <u>500</u>	Center Contact Captivation	
Contact Resistance (Milliohms MAX)	Axial (Lbs) <u>6.0</u>	
Center Contact <u>3.0</u>	Radial (In-Oz) <u>N/A</u>	
Outer Contact <u>2.0</u>	Cable Retention	
Cable to Housing <u>0.5</u>	Axial Force (Lbs) <u>20 MIN</u>	
RF High Potential @ Sea Level (VRMS MIN @ 5 MHz) <u>500</u>	Torque (In-Oz) <u>N/A</u>	
I.R.(Megohms MIN) <u>10,000</u>	Weight (Grams) <u>TBD</u>	

UNLESS OTHERWISE SPECIFIED DIMENSIONS ARE IN INCHES TOLERANCE ON	DRAWN BY <u>E.I.C.</u> DATE <u>5/16/69</u>			AMP Incorporated 140 Fourth Avenue Waltham, MA 02451-7599		
FRAC. DEC. ANGLES ± 1/64 ±.005 ± °	CHECKED BY <u>B.W.C.</u> DATE <u>5/17/69</u>					
These drawings and specifications are the property of M/A-COM Incorporated and shall not be reproduced or copied or used in whole or in part as the basis for the manufacture or sale of items without written permission.	APPD BY <u>D.NANIA</u> DATE <u>5/20/69</u>	TITLE <u>OSM STRAIGHT CABLE PLUG CRIMP ATTACHMENT</u>				
	USE ASS'Y PROCEDURE <u>408-4813</u> (REF 20-052) NO. AP. _____	SIZE <u>B</u>	CODE IDENT NO. <u>26805</u>	<u>2031-5012-02</u>	REV <u>03₃</u>	
		SCALE <u>3:1</u>			SHEET 1 OF 1	

CUSTOMER DRAWING

PART NO. 1051665-1
SHEET 1 OF 1, REV A