

## Product Specification for Reference Only

Issued Date: February , 3 , 2017

Rev. : K

Part Description: Ultrasonic Transducer

MURATA Part No.: MA40H1S-R

The product specification in this sheet is for reference only.  
The contents of this specification are subject to change.

You are requested to receive the latest specification and to return one copy of the specification to us with your receipt signature before going into mass production.

Product Promotion Sec.2  
Planning and Promotion Dept.  
Sensor Products Division  
Murata MFG. Co.,Ltd.

## Specification of Ultrasonic Transducer Type: MA40H1S-R

### 1. Scope

This product specification is applied to the ultrasonic transducer for distance detection that is consumer electronics products. Please contact us when using this product for any other applications than described in the above.

### 2. Customer Part Number

### 3. Murata Part Number

**MA40H1S-R**

### 4. Dimension

as per Fig.1

### 5. Ratings

	Items	Specification	Note
5-1	Operating temperature range	-20 to +60 degC	
5-2	Storage temperature range	-20 to +60 degC	
5-3	Rated Voltage	6.6Vp-p	at 40kHz , Square wave
5-4	Maximum Rated Voltage	7.2Vp-p	at 40kHz , Square wave

### 6. Specifications (\* Temperature 25±3 degree C, 45 to 60 % R.H, unless otherwise noted )

	Items	Specification	Note
6-1	Nominal frequency	40.0 kHz	
6-2	Sound Pressure Level	95dB min.	at 40kHz, 6Vp-p, Sine wave, 15cm 0 dB = 2x10 <sup>-5</sup> Pa (per measuring circuit Fig.2)
6-3	Sensitivity	-65dB min	at 40kHz , Sine wave, 15cm 0dB=1V/Pa (per measuring circuit Fig.3)
6-4	Capacitance	4500pF ± 20%	at 1kHz
6-5	Insulation Resistance	100 Mohm min.	at 25V D.C.

### 7. Packing information

Form of packing	Reel dimension	PCS per reel
Tape & Reel	Φ180mm	1000pcs

## 8. Environmental tests (Standard Test Condition: 25 ± 3 deg C, 45 to 60 % R.H)

### 8.1 Shock Test

Fulfill the condition1 after following test.

Acceleration	:	sine 980 m/s <sup>2</sup> (100G), 6ms
Direction	:	3 directions
Shock time	:	3times / directions, 18times in total

### 8.2 Vibration Test

Fulfill the condition1 after following test.

Vibration frequency:	:	10 to 55 Hz
Sweep Period	:	5 min.
Amplitude	:	1.5 mm
Directions	:	3 directions
Time	:	1 hour / direction

### 8.3 High Temperature Test

Fulfill the condition1 after following test.

Temperature	:	+85 deg C
Time	:	500 hours

### 8.4 Low Temperature Test

Fulfill the condition1 after following test.

Temperature	:	-40 deg C
Time	:	500 hours

### 8.5 Humidity Test

Fulfill the condition1 after following test.

Temperature	:	+60 deg C
Humidity	:	95 % R.H.
Time	:	500 hours

### 8.6 Temperature cycling

Fulfill the condition1 after following test.

-40 deg C /30min ← → +85 deg C /30min  
100Cycle

### 8.7 Operating Test

Fulfill the condition1 after following test.

Input voltage	:	6Vp-p at Square wave, 40kHz Continuous signal
Time	:	1000hours

### 8.8 Substrate Bending

Fulfill the condition1 after following test.

Apply 0.5 mm/s pressure on the substrate by 3mm bending width, as showing Chart 2, and keep that condition for 3 seconds.

### 8.9 Drop

Fulfill the condition1 after following test.

At height of 75cm, naturally detach from P-tile, 3 times.

### 8.10 ESD

Fulfill the condition1 after following test without appearance destroyed.

After setting the switch S to power supply position and charging the capacitor C1 at 1,000V, set the switch S to the other position to discharge through the test terminals, terminal No.1 and No.3, connecting the resistance R1 as showing Chart 3.

C1=100pF

R1=1.5k  $\Omega$

### 8.11 Resistance to soldering heat

Reflow soldering:

Fulfill the condition 1, four hours after applying twice of the reflow soldering according to reflow profile Chart 1.

Hand soldering:

This product does not support hand soldering.

Flow soldering:

This product does not support flow soldering.

[Condition 1]

The variation of the sound pressure level at 40 kHz is within 5dB compared with initial figures at 25 deg C after following test conditions

**Chart1**

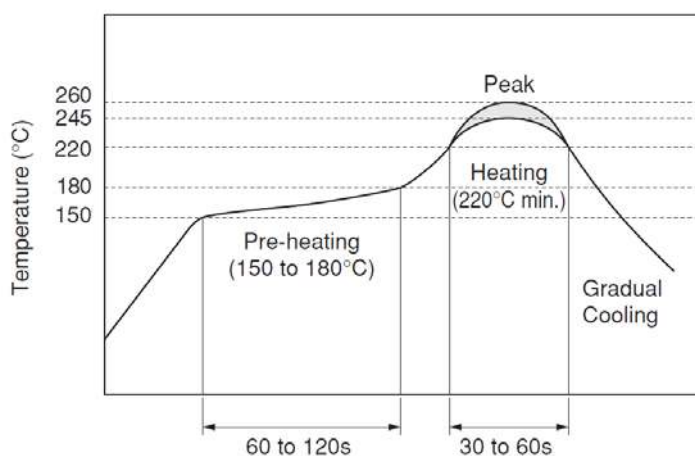

Reflow Profile

Chart2

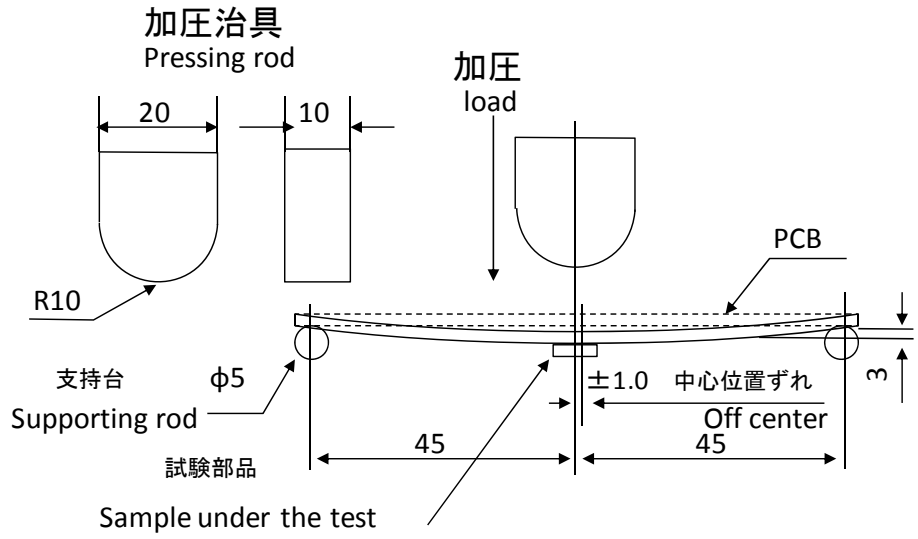
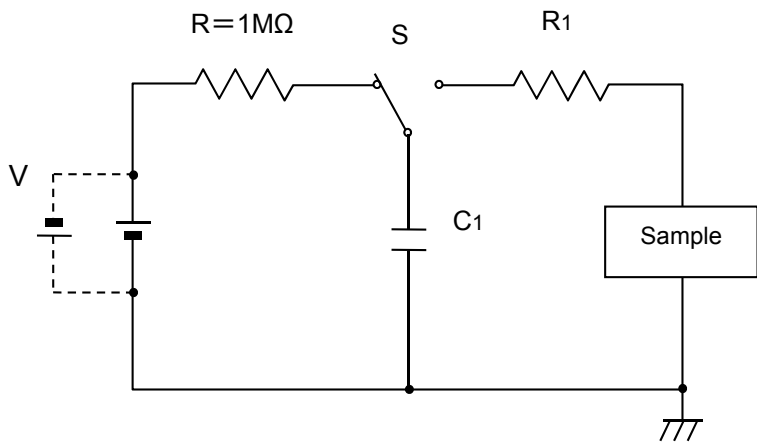

Chart3



## 9. Caution

### 9-1 Limitation of Applications

Please don't use for the applications listed below which require especially high reliability for the prevention of defects which might directly cause damage to the third party's life, body or property.

- 1) Aircraft equipment
- 2) Aerospace equipment
- 3) Undersea equipment
- 4) Power plant control equipment
- 5) Medical equipment
- 6) Transportation equipment (vehicles, trains, ships, etc.)
- 7) Traffic signal equipment
- 8) Disaster prevention / crime prevention equipment
- 9) Data-processing equipment
- 10) Application of similar complexity and/or reliability requirement to the applications listed in the above

### 9-2 Fail-safe

Be sure to provide an appropriate fail-safe function on your product to prevent a second damage that may be caused by the abnormal function or the failure of our product.

## 10. Caution in use

### 10-1 (Notice in design and usage)

- 1) The transducer may generate surge voltage by mechanical or thermal shock.
- 2) Please do not apply D.C.voltage for ultrasonic transducer to avoid depolarization, or silver migration of electrode on piezoelectric ceramic.
- 3) Please do not use this ultrasonic sensor in water.
- 4) Please do not apply an excessive mechanical shock or force on the top of this ultrasonic transducer and terminal pins. It may cause of disconnection and malfunction.
- 5) Care should be taken when select the material to hold, or cover backside of transducer. If it contains sulfur or sulfide, electrode on piezo-electric element may corroded and because of malfunction.
- 6) Please do not use nor storage this ultrasonic transducer in heavy dust condition. It may be a cause of clogging and low performance. Also, please do not use this transducer in high humidity or high concentrated exhaust gas. It may be a cause of corrosion and malfunction.
- 7) This transducer does not have a definition of terminal polarity. Please check a signal before using if you need a signal phase control for your application.

### 10-2 (Notice in storage)

- 1) The products should not be used or stored in a corrosive atmosphere, especially where chloride gas, sulfide gas, acid, alkali, salt or the like are present. Store the products in the room where is normal temperature and humidity, and avoid the sunlight, sudden changes in temperature and humidity. It may cause of failure or malfunction in such conditions.
- 2) Please do not use and storage this ultrasonic sensor in heavy dust and high humidity condition.
- 3) Store the products where the temperature and relative humidity do not exceed -10 to 40 degrees centigrade, and 30 to 80%RH. Use the products within 6 months after receiving.

### 10-3 (Notice in mounting)

- 1) Please do not clean by water and dissolvent.

## 11. Note

- 1) Please make sure that your product has been evaluated in view of your specifications with our product being mounted to your product.
- 2) You are requested not to use our product deviating from the agreed specifications.
- 3) We consider it not to appropriate to include any terms and conditions with regard to the business transaction in the product specifications, drawings or other technical documents. Therefore, if your technical documents as above include such terms and conditions such as warranty clause, product liability clause, or intellectual property infringement liability clause, they will be deemed to be invalid.

Dimensions

Unit : mm

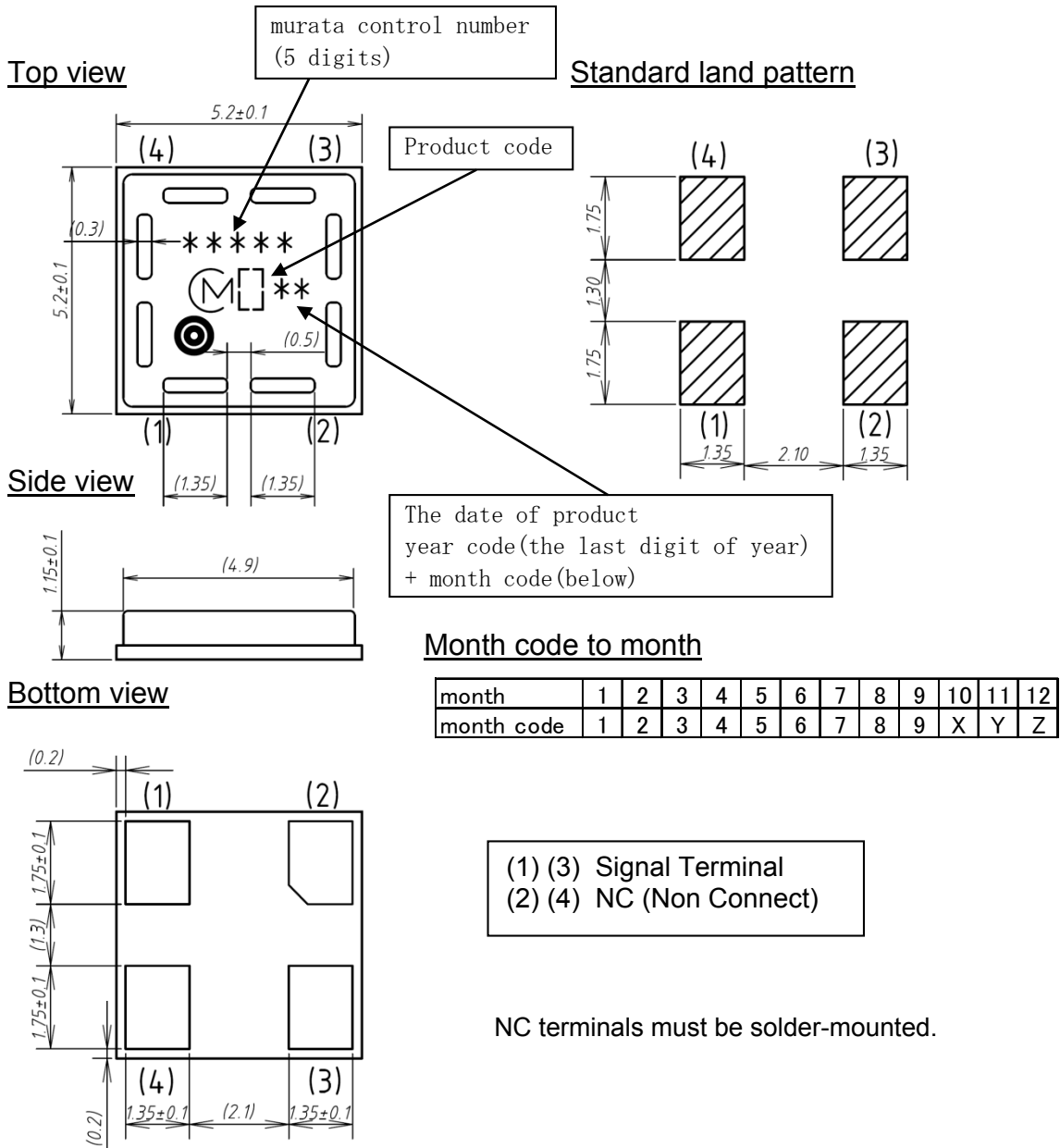
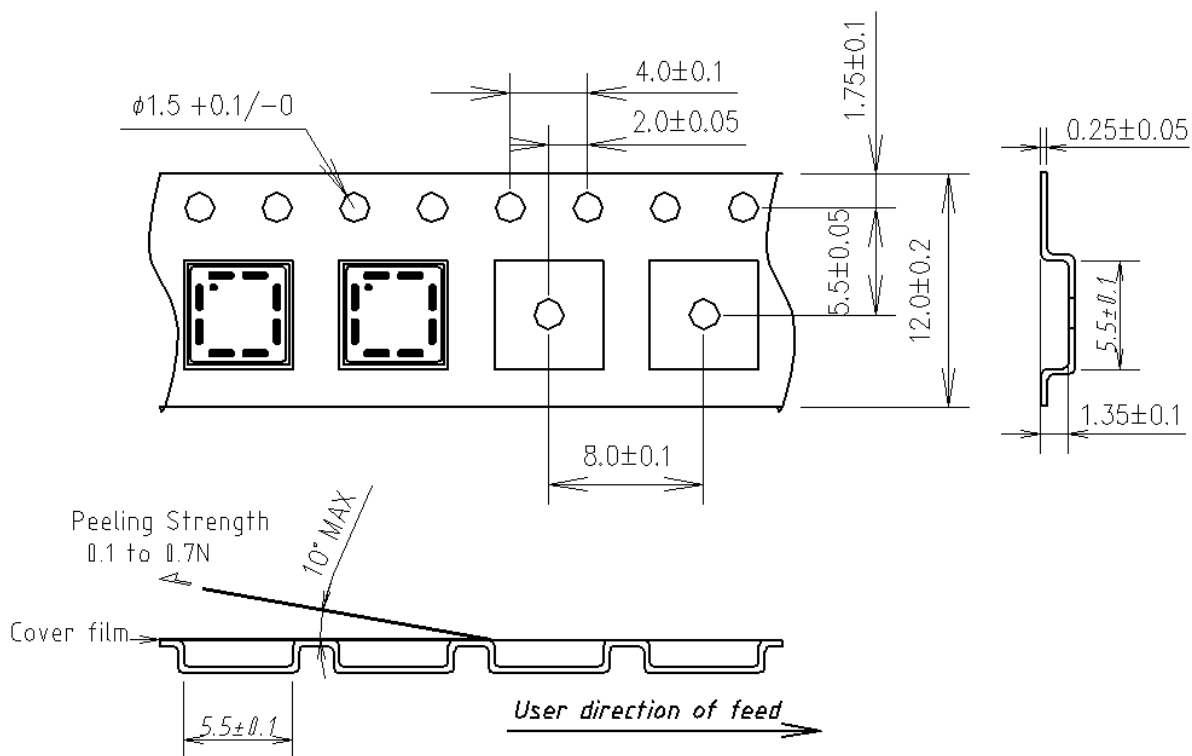

Fig.1

Embossed carrier tape:

Unit : mm



Dimensions of Reel

Unit : mm

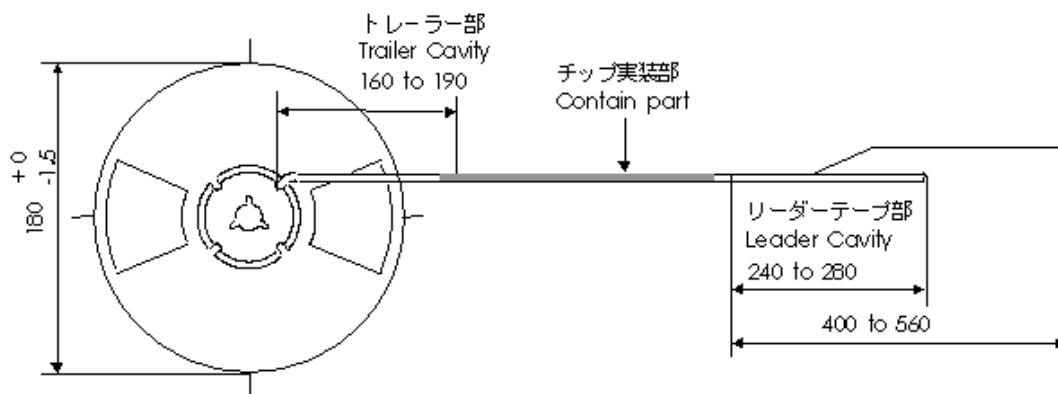

The tape for transducer shall be wound clockwise. The feeding holes shall be to the right side as the tape is pulled toward the user.



## Measuring circuit

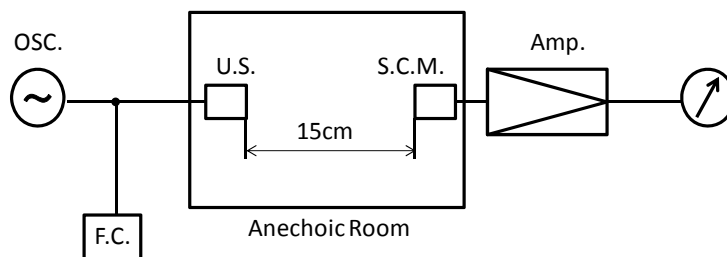

OSC. : Oscillator  
 U.S. : Ultrasonic Sensor(MA40H1S)  
 S.C.M : Standard Condenser Microphone (Brüel & kjær 4939-A-011)  
 Amp. : Amplifier(Brüel & kjær 2690-A-0S2)  
 F.C. :Frequency Counter  
 0dB = 20 $\mu$ Pa

Fig.2

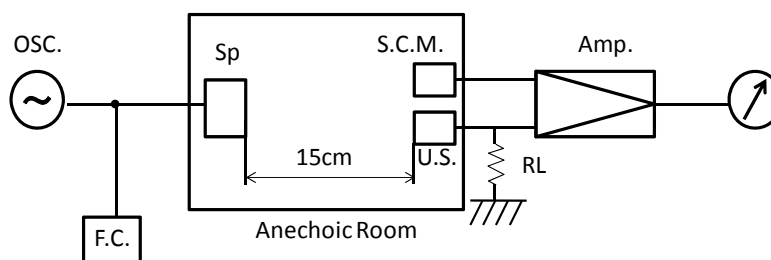

RL : 1.0k $\Omega$   
 U.S. : Ultrasonic Sensor(MA40H1S)  
 S.C.M : Standard Condenser Microphone (Brüel & kjær 4939-A-011)  
 Amp. : Amplifier(Brüel & kjær 2690-A-0S2)  
 OSC. : Oscillator  
 Sp. : Speaker  
 F.C. :Frequency Counter  
 0dB = 1V/Pa

Fig.3