

NPN POWER SILICON TRANSISTOR

Qualified per MIL-PRF-19500/498

Devices

2N6306

2N6308

Qualified Level

JAN
JANTX
JANTXV

MAXIMUM RATINGS

Ratings	Symbol	2N6306	2N6308	Units
Collector-Emitter Voltage	V_{CEO}	250	350	Vdc
Collector-Base Voltage	V_{CBO}	500	700	Vdc
Emitter-Base Voltage	V_{EBO}	8.0		Vdc
Collector Current	I_C	8.0		Adc
Base Current	I_B	4.0		Adc
Total Power Dissipation	P_T	@ $T_C = +25^{\circ}C^{(1)}$	125	W
		@ $T_C = +100^{\circ}C^{(1)}$	62.5	W
Operating & Storage Temperature Range	T_{op}, T_{stg}	-65 to +200		$^{\circ}C$

1) Between $T_C = +25^{\circ}C$ and $T_C = +175^{\circ}C$, linear derating factor average = 0.833 W/ $^{\circ}C$

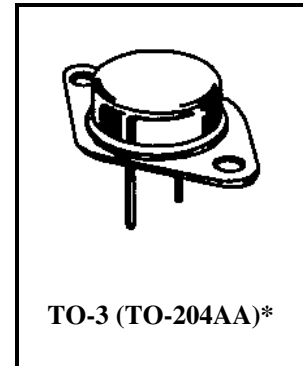

*See Appendix A for Package Outline

ELECTRICAL CHARACTERISTICS

Characteristics	Symbol	Min.	Max.	Unit
-----------------	--------	------	------	------

OFF CHARACTERISTICS

Collector-Base Breakdown Voltage $I_C = 100 \text{ mAdc}$	2N6306 2N6308	$V_{(BR)CEO}$	250 350	Vdc
Collector-Emitter Cutoff Current $V_{CE} = 500 \text{ Vdc}; V_{BE} = 1.5 \text{ Vdc}$ $V_{CE} = 700 \text{ Vdc}; V_{BE} = 1.5 \text{ Vdc}$	2N6306 2N6308	I_{CEX}	5.0 5.0	μAdc
Collector-Emitter Cutoff Current $V_{CE} = 250 \text{ Vdc}$ $V_{CE} = 350 \text{ Vdc}$	2N6306 2N6308	I_{CEO}	50 50	μAdc
Emitter-Base Cutoff Current $V_{EB} = 8 \text{ Vdc}$		I_{EBO}	5.0	μAdc

2N6306, 2N6308 JAN SERIES

ELECTRICAL CHARACTERISTICS (con't)

Characteristics		Symbol	Min.	Max.	Unit
DC CHARACTERISTICS ⁽²⁾					
Forward-Current Transfer Ratio $I_C = 3.0 \text{ Adc}; V_{CE} = 5.0 \text{ Vdc}$	2N6306	h_{FE}	15	75	
	2N6308		12	60	
$I_C = 8.0 \text{ Adc}; V_{CE} = 5.0 \text{ Vdc}$	2N6306		4		
	2N6308		3		
$I_C = 0.5 \text{ Adc}; V_{CE} = 5.0 \text{ Vdc}$	2N6306		15		
	2N6308		12		
Base-Emitter Voltage $V_{CE} = 5.0 \text{ Vdc}; I_C = 3.0 \text{ Adc}$	2N6306	$V_{BE(on)}$		1.3	Vdc
	2N6308			1.5	
Base-Emitter Saturated Voltage $I_B = 2.0 \text{ Adc}; I_C = 8.0 \text{ Adc}$	2N6306	$V_{BE(sat)}$		2.3	Vdc
$I_B = 2.67 \text{ Adc}; I_C = 8.0 \text{ Adc}$	2N6308			2.5	
Collector-Emitter Saturated Voltage $I_B = 2.0 \text{ Adc}; I_C = 8.0 \text{ Adc}$	2N6306	$V_{CE(sat)}$		5.0	Vdc
$I_B = 2.67 \text{ Adc}; I_C = 8.0 \text{ Adc}$	2N6308			5.0	
$I_B = 0.6 \text{ Adc}; I_C = 3.0 \text{ Adc}$	2N6306			0.8	
	2N6308			1.5	

DYNAMIC CHARACTERISTICS

Magnitude of Common-Emitter Small-Signal Short-Circuit Forward Current Transfer Ratio $I_C = 0.3 \text{ Adc}, V_{CE} = 10 \text{ Vdc}, f = 1 \text{ MHz}$		$ h_{fe} $	5	30	
Small-Signal Short-Circuit Forward Current Transfer Ratio $I_C = 0.5 \text{ Adc}, V_{CE} = 4.0 \text{ Vdc}, f = 1.0 \text{ kHz}$		h_{fe}	5		
Output Capacitance $V_{CB} = 10 \text{ Vdc}, I_E = 0, 100 \text{ kHz} \leq f \leq 1.0 \text{ MHz}$		C_{obo}		250	pF

SWITCHING CHARACTERISTICS

Turn-On Time $V_{CC} = 125 \text{ Vdc}; I_C = 3.0 \text{ Adc}; I_B = 0.6 \text{ Adc}$		t_{on}		0.6	μs
Turn-Off Time $V_{CC} = 125 \text{ Vdc}; I_C = 3.0 \text{ Adc}; I_{B1} = 0.6 \text{ Adc}; I_{B2} = 1.5 \text{ Adc}$		t_{off}		3.0	μs

SAFE OPERATING AREA

DC Tests					
$T_C = +25^\circ\text{C}; t = 1 \text{ s}, 1 \text{ cycle (See Figure 2 and 3 of MIL-PRF-19500/498)}$					
Test 1					
$V_{CE} = 15.6 \text{ Vdc}, I_C = 8 \text{ Adc}$					
Test 2					
$V_{CE} = 37 \text{ Vdc}, I_C = 3.4 \text{ Adc}$					
Test 3					
$V_{CE} = 200 \text{ Vdc}, I_C = 65 \text{ mAdc}$	2N6306				
$V_{CE} = 300 \text{ Vdc}, I_C = 25 \text{ mAdc}$	2N6308				

2.) Pulse Test: Pulse Width = 300 μs , Duty Cycle $\leq 2.0\%$.