
EQCO30R5.D 3G/HD-SDI Video Cable Equalizer

Features

- Supports up to 140 Meters of Cable at 2.97 Gbps Using High-Quality Coax
- Supports up to 200 Meters of Cable at 1.485 Gbps Using High-Quality Coax
- Supports up to 450 Meters of Cable at 270 Mbps Using High-Quality Coax
- Compatible with all SMPTE3G SDI Data Rates:
 - SMPTE259M SDI, 143 to 360 Mbps
 - SMPTE344M, 540 Mbps
 - SMPTE292M HD-SDI, 1.485 Gbps
 - SMPTE372M Dual-Link HD-SDI, 2.97 Gbps
 - SMPTE424M Dual-Speed 3G-SDI, 2.97 Gbps
- Pin Compatible with Gennum and National Semiconductor Parts
- Also Operates with 8B/10B Coding
- Single 3.3V Supply.
- Low Power Consumption (220 mW, 3.3V Supply; 80 mW, 1.2V Supply)
- Better Robustness Due to Transmit Amplitude Independent Operation
- 16-Pin, 0.65 mm Pin Pitch, 4 mm QFN Package
- -40°C to +85°C Industrial Temperature Range
- Pb-Free and RoHS Compliant

Applications

- High Definition, High Frame Rate Pro-Video HD-SDI Frame Store
- Surveillance, Industrial/Inspection, Medical Video Inputs
- HDcctv Applications

Note: The EQCO30R5 video equalizer can be used in combination with the EQCO30T5 cable driver. This device is capable of receiving the uplink signal whilst other key parameters remain compliant to SMPTE specifications. Please refer to the Microchip website (www.microchip.com) for the EQCO30T5 data sheet.

Introduction

The EQCO30R5 is a video equalizer for 3G/HD/SD-SDI video, with speeds up to 2.97 Gbps. It is designed to be a direct replacement for competing video equalizers. In addition to downlink functionality from camera to frame grabber, it can also transmit a 5 Mbps uplink signal from the frame grabber to the camera. Additionally, power can be provided over the same cable using the same chip and a few external components. The device operates with 8B/10B coded signals up to 3.125 Gbps.

EQCO30R5.D

Typical Link Performance

Table 1, Table 2, and Table 3 give an overview of video equalizer typical performance at room temperature without using the uplink and without providing power over the same coax. When providing power or using the uplink communication to the camera, a small length penalty may arise (in cable length, typically 10%) due to added parasitics and noise. The uplink operates to at least 400m at the 5 Mbps bit rate.

TABLE 1: BELDEN TYPICAL EQUALIZATION PERFORMANCE

	Name	Belden 7731A	Belden 1694A	Belden 1505A	Belden 1505F	Belden 1855A
	Type	Long Distance	Industry Standard	Compromise Coax	Flexible	Thinnest Cable
Diameter	(mm)	10.3	6.99	5.94	6.15	4.03
270 Mbps	(m)	718	469	384	302	270
1.485 Gbps	(m)	332	223	187	136	132
2.97 Gbps	(m)	219	149	128	89	91

TABLE 2: GEPKO TYPICAL EQUALIZATION PERFORMANCE

	Name	Gepco VHD1100	Gepco VSD2001	Gepco VPM2000	Gepco VHD2000M	Gepco VDM230
	Type	Long Distance	Industry Standard	Compromise Coax	Flexible	Thinnest Cable
Diameter	(mm)	10.3	6.91	6.15	6.15	4.16
270 Mbps	(m)	772	502	387	305	273
1.485 Gbps	(m)	372	241	187	138	133
2.97 Gbps	(m)	252	163	128	91	92

TABLE 3: CANARE TYPICAL EQUALIZATION PERFORMANCE

	Name	Canare L-7CFB	Canare L-5CFB	Canare L-4CFB	Canare L-3CFB	Canare L-2.5CFB
	Type	Long Distance	Industry Standard	Compromise Coax	Thin Cable	Thinnest Cable
Diameter	(mm)	10.3	6.99	5.94	6.15	4.03
270 Mbps	(m)	615	434	344	287	223
1.485 Gbps	(m)	281	201	161	135	109
2.97 Gbps	(m)	182	132	107	90	73

Table of Contents

1.0 Device Overview	4
2.0 Application Information	8
3.0 Electrical Characteristics	12
4.0 Packaging	14

TO OUR VALUED CUSTOMERS

It is our intention to provide our valued customers with the best documentation possible to ensure successful use of your Microchip products. To this end, we will continue to improve our publications to better suit your needs. Our publications will be refined and enhanced as new volumes and updates are introduced.

If you have any questions or comments regarding this publication, please contact the Marketing Communications Department via E-mail at docerrors@microchip.com or fax the **Reader Response Form** in the back of this data sheet to (480) 792-4150. We welcome your feedback.

Most Current Data Sheet

To obtain the most up-to-date version of this data sheet, please register at our Worldwide Website at:

<http://www.microchip.com>

You can determine the version of a data sheet by examining its literature number found on the bottom outside corner of any page. The last character of the literature number is the version number, (e.g., DS30000A is version A of document DS30000).

Errata

An errata sheet, describing minor operational differences from the data sheet and recommended workarounds, may exist for current devices. As device/documentation issues become known to us, we will publish an errata sheet. The errata will specify the revision of silicon and revision of document to which it applies.

To determine if an errata sheet exists for a particular device, please check with one of the following:

- Microchip's Worldwide Website; <http://www.microchip.com>
- Your local Microchip sales office (see last page)

When contacting a sales office, please specify which device, revision of silicon and data sheet (include literature number) you are using.

Customer Notification System

Register on our website at www.microchip.com to receive the most current information on all of our products.

EQCO30R5.D

1.0 DEVICE OVERVIEW

Note: Email address: eqcoproducts@microchip.com

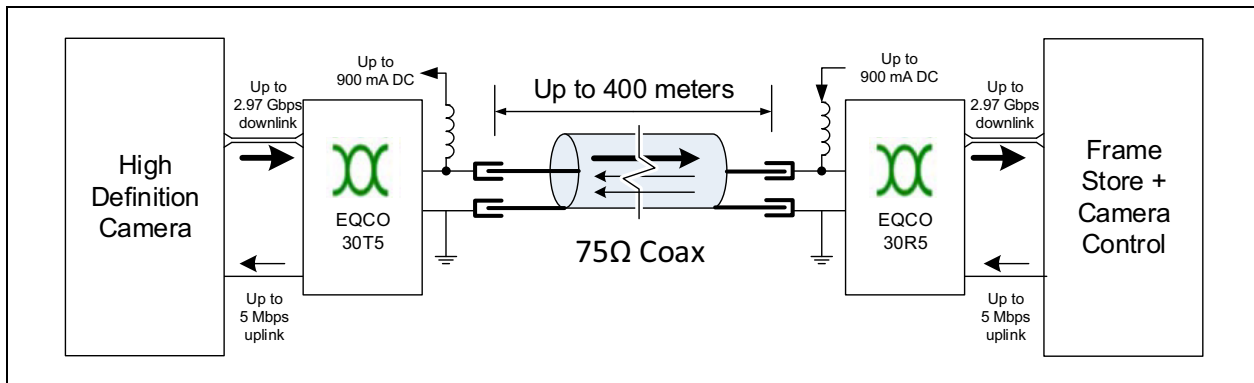
The EQCO30R5 is a multi-rate adaptive cable equalizer, designed to restore signals received over coaxial cable. The EQCO30R5 chip is optimized for SMPTE HD/SDI signals, but works equally well with 8B/10B coded signals. The device operates from a single 3.3V power supply. A sister device operates from a single 1.2V power supply, which reduces power consumption at the cost of voltage compatibility with competitive parts. For more information on the 1.2V part, please contact Microchip.

The EQCO30T5 is a cable driver that matches to the EQCO30R5, since it can receive the uplink signal. Implementing the uplink requires very few additional components on both sides of the link and complies with SMPTE specifications. The EQCO30T5 data sheet is available separately from Microchip.

The EQCO30R5 has a DC restore circuit to recover SMPTE pathological patterns in the data stream. The EQCO30R5 has a variable gain to compensate for low-frequency attenuation through the coax and variations in transmit amplitude.

Figure 1-1 shows a typical communication link using the EQCO30T5 and EQCO30R5 chips

FIGURE 1-1: TYPICAL EQCO30R5 SETUP



1.1 Pinout and Pin Description

FIGURE 1-2: EQCO30R5.D PIN DIAGRAM (VIEWED FROM TOP)

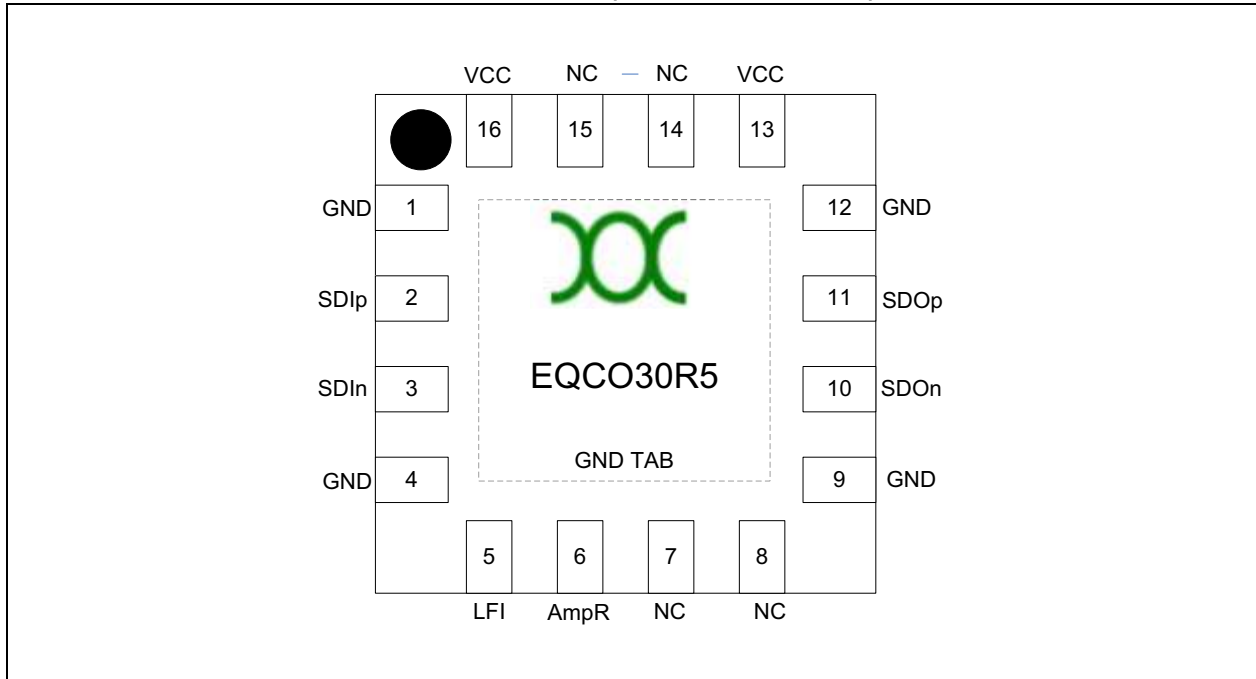


TABLE 1-1: EQCO30R5.D PIN DESCRIPTIONS

Pin Number	Pin Name	Signal Type	Description
(TAB)	GND	Power	Use as single-point ground.
13, 16	VCC	Power	+3.3V of power supply.
1, 4, 9, 12	GND	Power	Connect to ground of power supply.
2, 3	SDIp, SDIn	CML Input	Serial input positive/negative differential serial input. Connect SDIn to ground reference via termination network. External 75Ω resistors are required.
11, 10	SDOp/SDOn	CML Output	Serial output positive/negative differential serial output. Output has a swing of 2x370 mV and has 50Ω on-chip termination resistors to internal V _{DD} (1.2V).
5	LFI	Input	Uplink signal. (Low = 0V, High = 1.2V). When driving from 3.3V, an external series resistance of 6.2 kΩ is required.
6	AmpR	Input	Connect to ground with a 1 kΩ resistor, defining the uplink amplitude to 150 mV.
7	NC	Input	Do not connect. Used for internal testing.
8	NC	Input	Do not connect. Used for internal testing.
14	NC	Input	Do not connect. Used for internal testing.
15	NC	Input	Do not connect. Used for internal testing.

EQCO30R5.D

1.1.1 SDIp/SDIn

SDIp/SDIn together form a differential input pair. The EQCO30R5 analyzes the differential voltage between these pins and adaptively equalizes for signal level and frequency response. The equalizer automatically detects and adapts to signals with different edge rates, different attenuation levels and different cable characteristics. Both SDIp and SDIn inputs need to be terminated by an external 75Ω resistor to GND.

1.1.2 SDOp/SDOn

SDOp/SDOn together form a differential CML pair outputting the reconstructed far-end transmit signal. SDOp/SDOn are terminated on-chip with two 50Ω resistors to 1.2V. These outputs should be AC coupled to the deserializer (unless a 800 mV-1V common-mode voltage is acceptable). For SMPTE signals, it is best to use 4.7 μF AC coupling capacitors.

1.1.3 LFI

LFI is the uplink input signal that will be transmitted on the SDIp/SDIn pair. LFI must be a 0-1.2V signal. The pin has an internal resistor of 3.6 kΩ. When driving with a 3.3V (2.5V) signal, an external resistor of 6.2 kΩ (3.9 kΩ) should be placed in series close to the EQCO30R5 chip. When not using uplink communications, leave this pin floating.

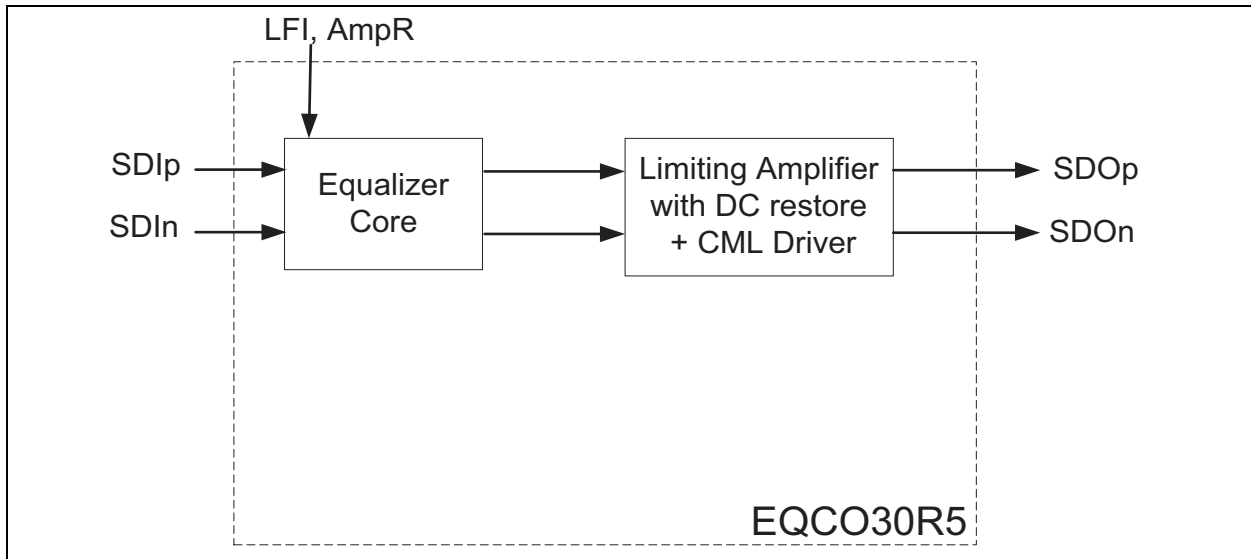
When the downlink signal is 8b/10b coded, the uplink signal can be 8b/10b at 5 Mbps. When the downlink signal is a SMPTE signal, the uplink signal cannot be 5 Mbps but needs to be a lower speed signal modulated to a 5 Mbps. See application note “AN1837 HD-SDI Repeater Reference Design” for more information on modulation. This application note is made available under NDA.

1.1.4 AmpR

AmpR is a Vcc resistor that sets the transmit amplitude of the uplink output driver. The typical value is $R_{amp} = 1 \text{ k}\Omega$ for 150 mV transmit amplitude. When not using uplink communications, leave this pin floating.

1.2 Circuit Operation

FIGURE 1-3: EQCO30R5.D BLOCK DIAGRAM SHOWING ELECTRICAL CONNECTIONS



1.2.1 EQUALIZER CORE

The EQCO30R5 has an embedded equalizer in the receive path with the following characteristics:

- Auto-Adaptive

The equalizer controls a multiple-pole analog filter which compensates for attenuation of the cable, as illustrated in [Figure 1-4](#). The filter frequency response needed to restore the signal is automatically determined by the device using a time-continuous feedback loop that measures the frequency components in the signal. Upon the detection of a valid signal, the control loop converges within a few microseconds.

- Variable Gain

The EQCO30R5 equalizer has variable gain to compensate for low-frequency attenuation through the coax and variations in transmit amplitude; this makes the equalizer performance more robust, even at maximum cable lengths.

- Variable Coax

The equalizer can receive attenuated signals from other types of cables besides the Belden1694A.

- Multi-Speed

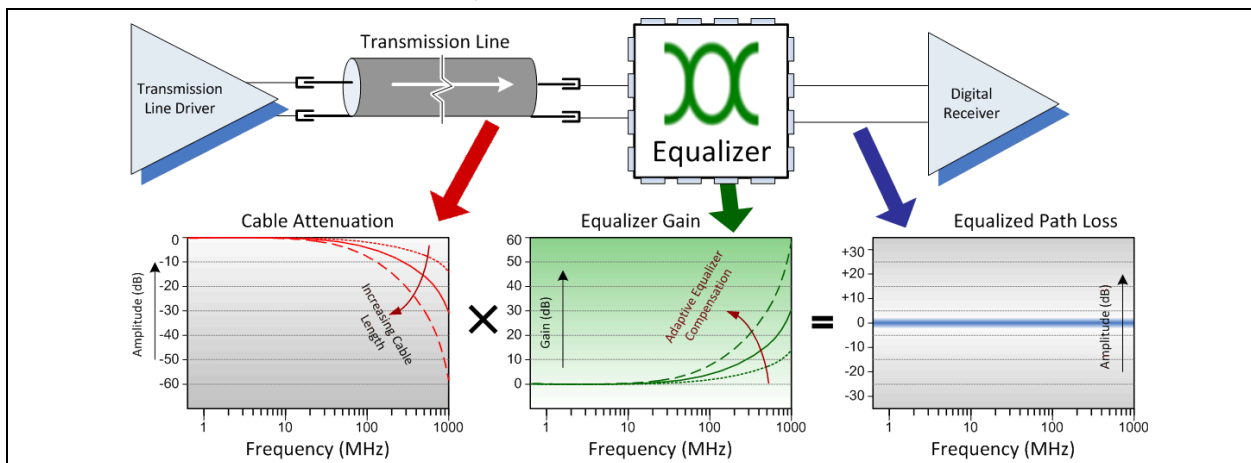
The EQCO30R5 works at data rates from 143 Mbps to 2.97 Gbps. With 8B/10B coding, the allowable bit rate is extended from 50 Mbps to 3.125 Gbps.

Example equalizer performance measurements can be found in [Appendix B: “Typical Equalizer Characteristics”](#).

1.2.2 RX OUTPUT DRIVER

The output driver converts the output of the equalizer core to an LVDS-like signal and sends it onto a 100Ω differential transmission line.

FIGURE 1-4: PRINCIPLE OF EQUALIZER OPERATION



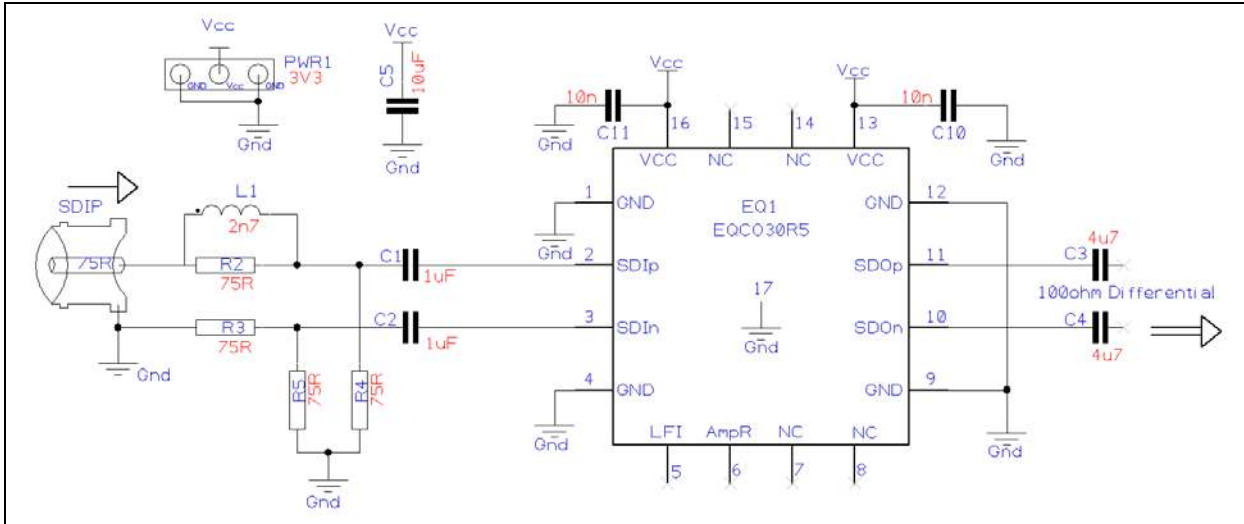
EQCO30R5.D

2.0 APPLICATION INFORMATION

2.1 Typical Application Circuit for SMPTE Video Signals

Figure 2-1 illustrates a typical schematic implementation of the EQCO30R5 used as an equalizer for SMPTE video signals.

FIGURE 2-1: EQCO30R5.D TYPICAL APPLICATION CIRCUIT FOR SMPTE VIDEO SIGNALS



2.1.1 RETURN-LOSS NETWORK

For optimal return-loss, an external return-loss network is needed. The value of R2 is 75Ω, and the value of L1 is 2.7 nH.

TABLE 2-1: COMPONENT RECOMMENDATION FOR THE EQCO30R5.D BOARD LAYOUT FOR SMPTE VIDEO SIGNALS

Element	Value	Size	Recommended Component
R2, R3, R4, R5	75Ω ±1%	0402	
L1	2.7 nH	0402	

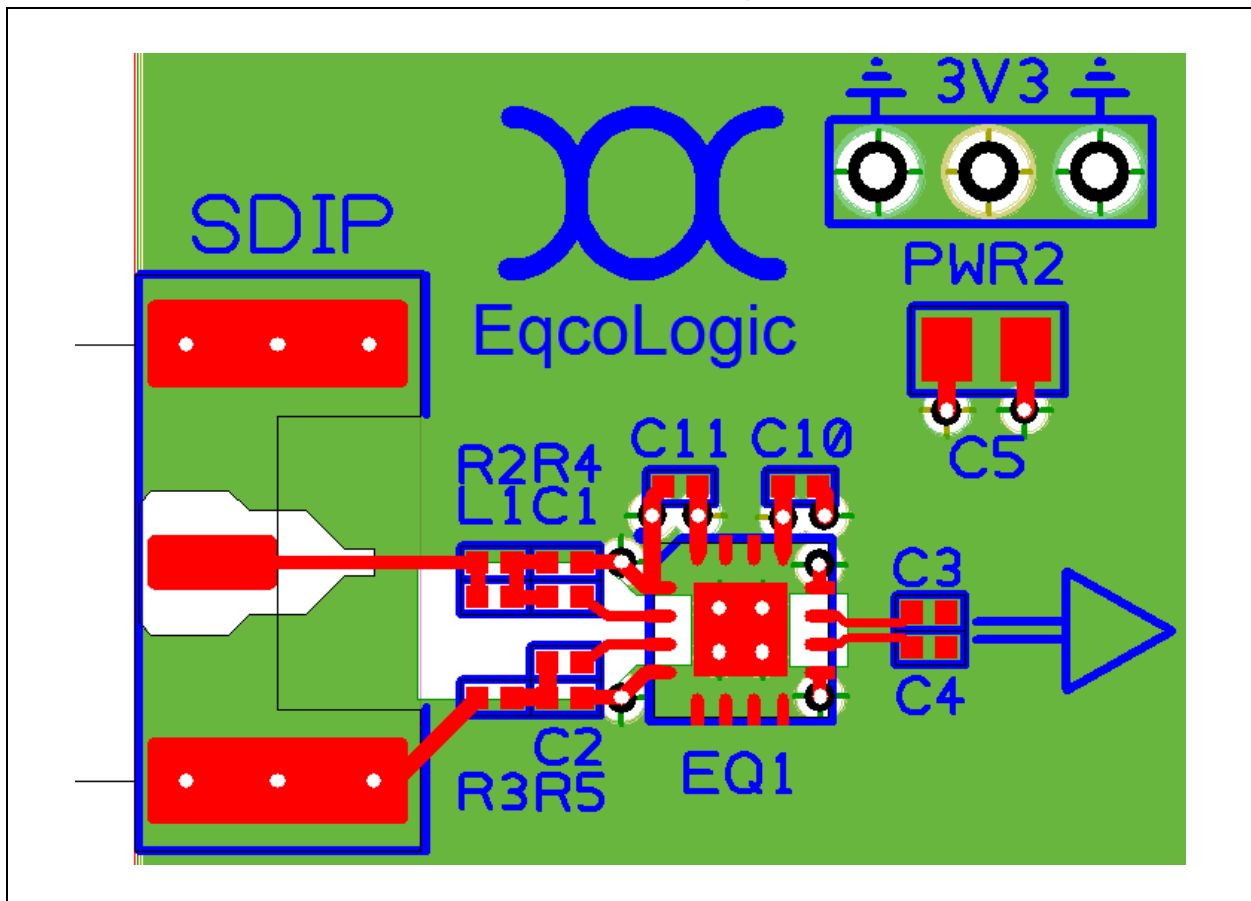
2.1.2 GUIDELINES FOR PCB LAYOUT

All components in the high-speed signal path should be 0402 size for minimal parasitic effects.

The transmission line between the BNC connector and the return-loss network (L1, R2) shall be a 75Ω single-ended transmission line. Components R2, R4 and R5 are 75Ω resistors, and component L1 is a 2.7 nH inductor. Component R3 is the 75Ω termination resistor to GND. Components C1 and C2 are AC coupling capacitors connected to the input of the chip. Two decoupling capacitors (C10, C11) are placed between Vcc and GND, close to the chip. The output of the chip is connected to the deserializer or FPGA with a 100Ω differential transmission line. To minimize unwanted parasitic effects, a cutout of the ground and power plane is made underneath capacitor C6 and underneath the input pins of the EQCO30R5 chip.

Figure 2-2 shows a recommended layout for the EQCO30R5 implementation.

FIGURE 2-2: RECOMMENDED PCB LAYOUT FOR EQCO30R5



EQCO30R5.D

2.2 Typical Application Circuit for Bidirectional Link with Power Over Coax

FIGURE 2-3: EQCO30R5.D TYPICAL APPLICATION CIRCUIT FOR BIDIRECTIONAL LINK WITH POWER OVER COAX

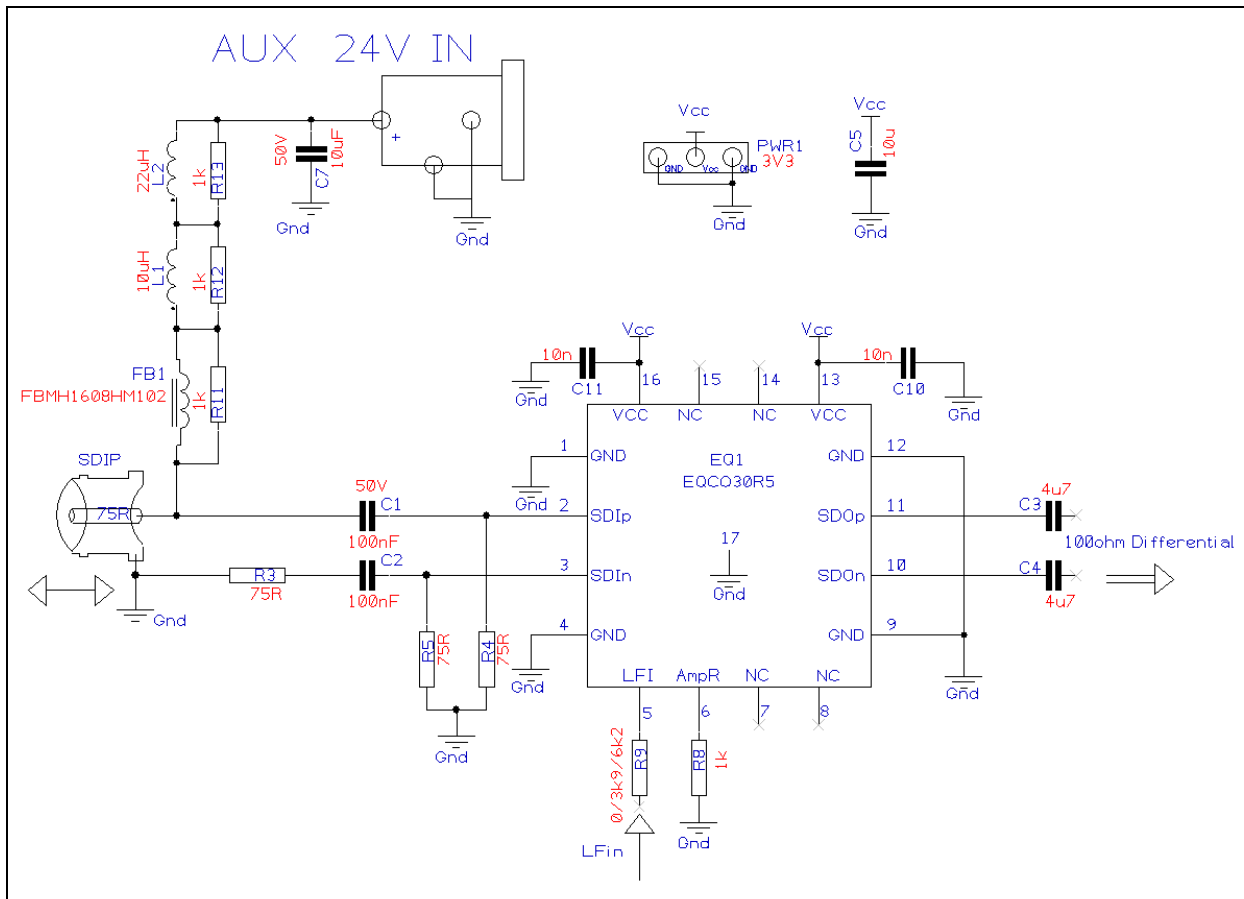


TABLE 2-2: COMPONENT RECOMMENDATION FOR THE EQCO30R5.D BOARD LAYOUT

Element	Value	Size	Recommended Component
Fb1, Fb2	1 kΩ @ 100 MHz Ferrite Bead	0603	FBMH1608HM102 from Taiyo Yuden
L1	10 µH	1812	1812PS_103 from Coilcraft

2.2.1 BIDIRECTIONAL LINK IN SMPTE APPLICATIONS

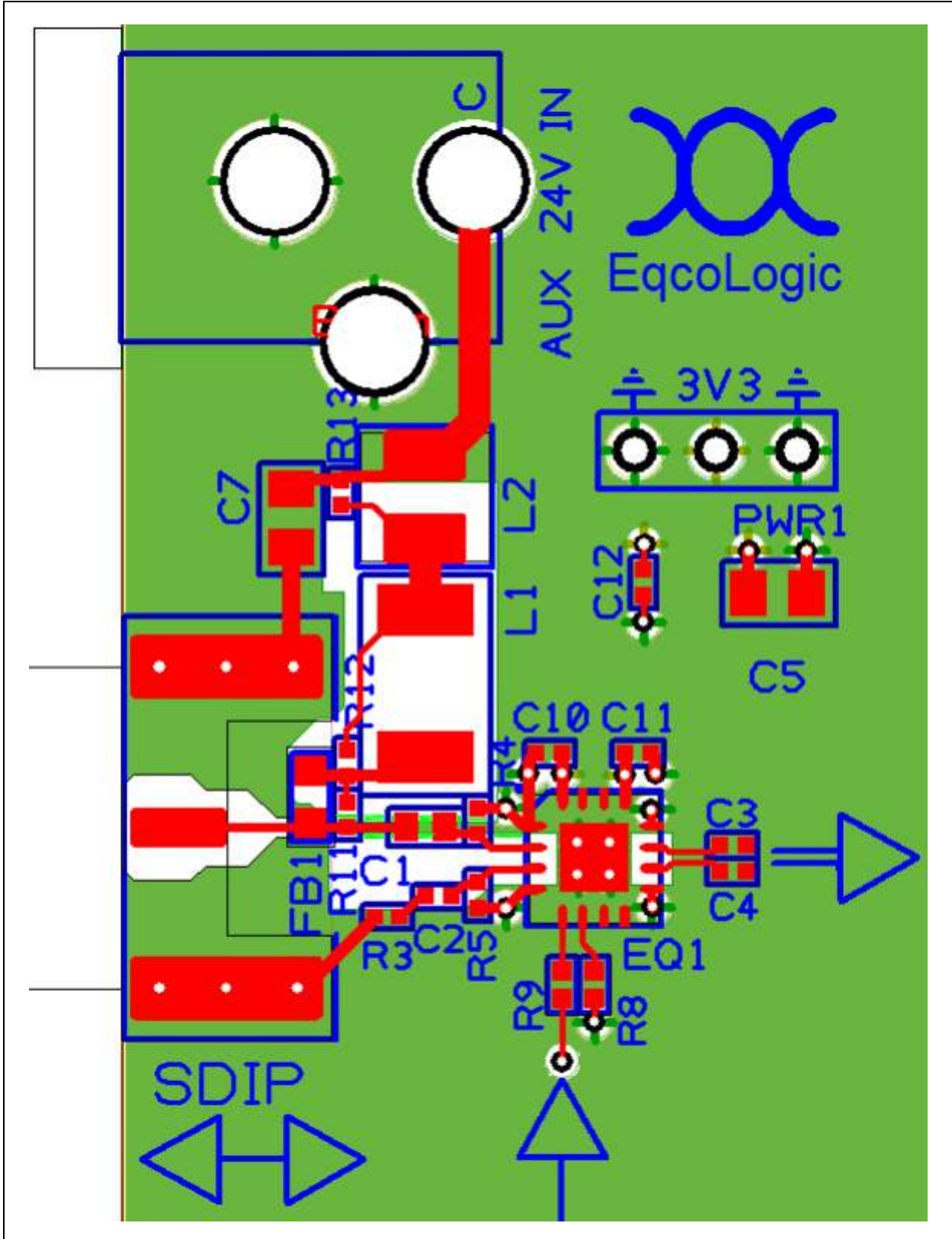
When using the bidirectional link with power supply transmission, the components (FB1, L1 and L2) and layout are very critical. Changes in the design or components may result in decreased performance.

2.2.2 PCB LAYOUT

All components in the high-speed signal path should be 0402 size for minimal parasitic effects.

Figure 2-4 shows a recommended layout for the EQCO30R5 with uplink and power over coax.

FIGURE 2-4: RECOMMENDED PCB LAYOUT FOR EQCO30R5 IN BIDIRECTIONAL LINK



EQCO30R5.D

3.0 ELECTRICAL CHARACTERISTICS

3.1 Absolute Maximum Ratings

Stresses beyond those listed under this section may cause permanent damage to the device. These are stress ratings only and are not tested. Functional operation of the device at these or any other conditions beyond those indicated in the operational sections are not implied. Exposure to absolute maximum rating conditions for extended periods may affect device reliability.

TABLE 3-1: ABSOLUTE MAXIMUM RATINGS

Parameter	Conditions	Min.	Typ.	Max.	Units
Storage Temperature	—	-65	—	+150	°C
Ambient Temperature	Power applied	-55	—	+125	°C
Operating Temperature	Normal operation (V _{CC} = 3.3V ±5%)	-40	—	+85	°C
Supply Voltage to Ground	—	-0.8	—	+3.6	V
DC Input Voltage	—	-0.8	—	+3.6	V
DC Voltage to Outputs	—	-0.8	—	+3.6	V
Current into Outputs	Outputs low	—	—	90	mA

TABLE 3-2: ELECTRICAL CHARACTERISTICS (OVER THE OPERATING V_{CC} AND -40 TO +85°C RANGE)

Parameter	Description	Min.	Typ.	Max.	Unit
Power Supply					
V _{CC}	Supply voltage	3.15	3.3	3.45	V
I _S	Supply current, both transmitting and receiving	—	55	—	mA
Operational Bit Rate					
BR _{SMPTE}	Bit rate using SMPTE data	0.143	—	3.0	Gbps
BR _{8B10B}	Bit rate using 8B/10B coded data	0.05	—	3.125	Gbps
SDIp Connection to Coax					
Z _{coax}	Coax cable characteristic impedance	—	75	—	Ω
R _{loss}	Coax return-loss as seen on SDIp pin. Frequency range = 1 MHz-1.5 GHz	—	—	-15	dB
R _{loss}	Coax return-loss as seen on SDIp pin Frequency range = 1.5 GHz-3 GHz	—	—	-10	dB
ΔV _{TX}	Transmit amplitude (at camera end into 75Ω)	500	800	1200	mV
SDOp/SDOn Outputs (CML to 1.2V)					
ΔV _O	Output amplitude V _{SDOp,n} (into 2x50Ω)	2x300	2x370	2x450	mV
V _{cmout}	Common-mode output voltage when AC coupled	—	0.83	—	V
R _{output}	Termination on SDOp/SDOn to V _{CC}	—	50	—	Ω
t _{rise_o}	Rise/Fall time 20% to 80% of V _{SDOp,n}	—	75	—	ps

TABLE 3-2: ELECTRICAL CHARACTERISTICS (OVER THE OPERATING V_{CC} AND -40 TO +85°C RANGE)

Uplink Parameters					
V _{LF}	Uplink transmit amplitude for R _{amp} = 1 kΩ measured inside cable	110	150	190	mV
t _{rise_1f}	Rise/Fall time 20% to 80% of LF output on SDIp with R _{amp} = 1 kΩ	30	40	55	ns
V _{ih}	LFI input high voltage	0.8	—	1.3	V
V _{il}	LFI input low voltage	-0.5	—	0.4	V
R _{input}	Internal resistor to GND	—	3.6	—	kΩ

TABLE 3-3: JITTER NUMBERS⁽¹⁾

Parameter	Conditions	Min.	Typ.	Max.	Units
Jitter in Equalizer Output	2.97 Gbps from 0-120m ⁽²⁾	—	—	0.25	UI
Jitter in Equalizer Output	2.97 Gbps from 120-140m ⁽²⁾	—	0.3	—	UI
Jitter in Equalizer Output	1.485 Gbps from 0-160m ⁽²⁾	—	—	0.25	UI
Jitter in Equalizer Output	1.485 Gbps from 160-200m ⁽²⁾	—	0.3	—	UI
Jitter in Equalizer Output	270 Mbps from 0-400m ⁽²⁾	—	—	0.2	UI
Additive Jitter on LF Output	8B/10B coded signal at 5 Mbps over full V _{CC} and temperature range.	—	—	10	ns
DCD in LF Output	8B/10B coded signal at 5 Mbps over full V _{CC} and temperature range.	—	—	10	ns

1: Jitter numbers (over operating V_{CC} range at -40°C to +85°C and full ΔV_{TX} range with pathological patterns)

2: Measured with Belden 1694A

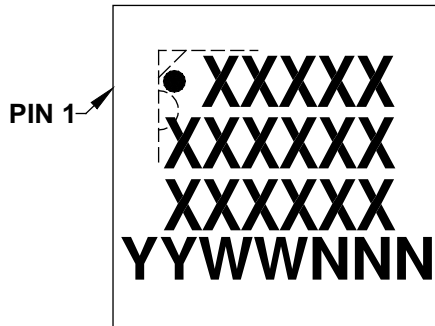
EQCO30R5.D

4.0 PACKAGE INFORMATION

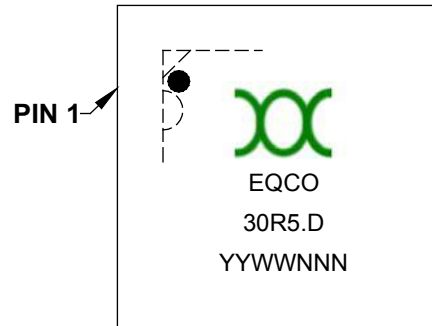
4.1 Package Marking Information

16-Lead Plastic Quad Flat, No Lead Package – 4x4x0.9 mm Body [QFN]

16-Lead QFN (4x4x0.9 mm)



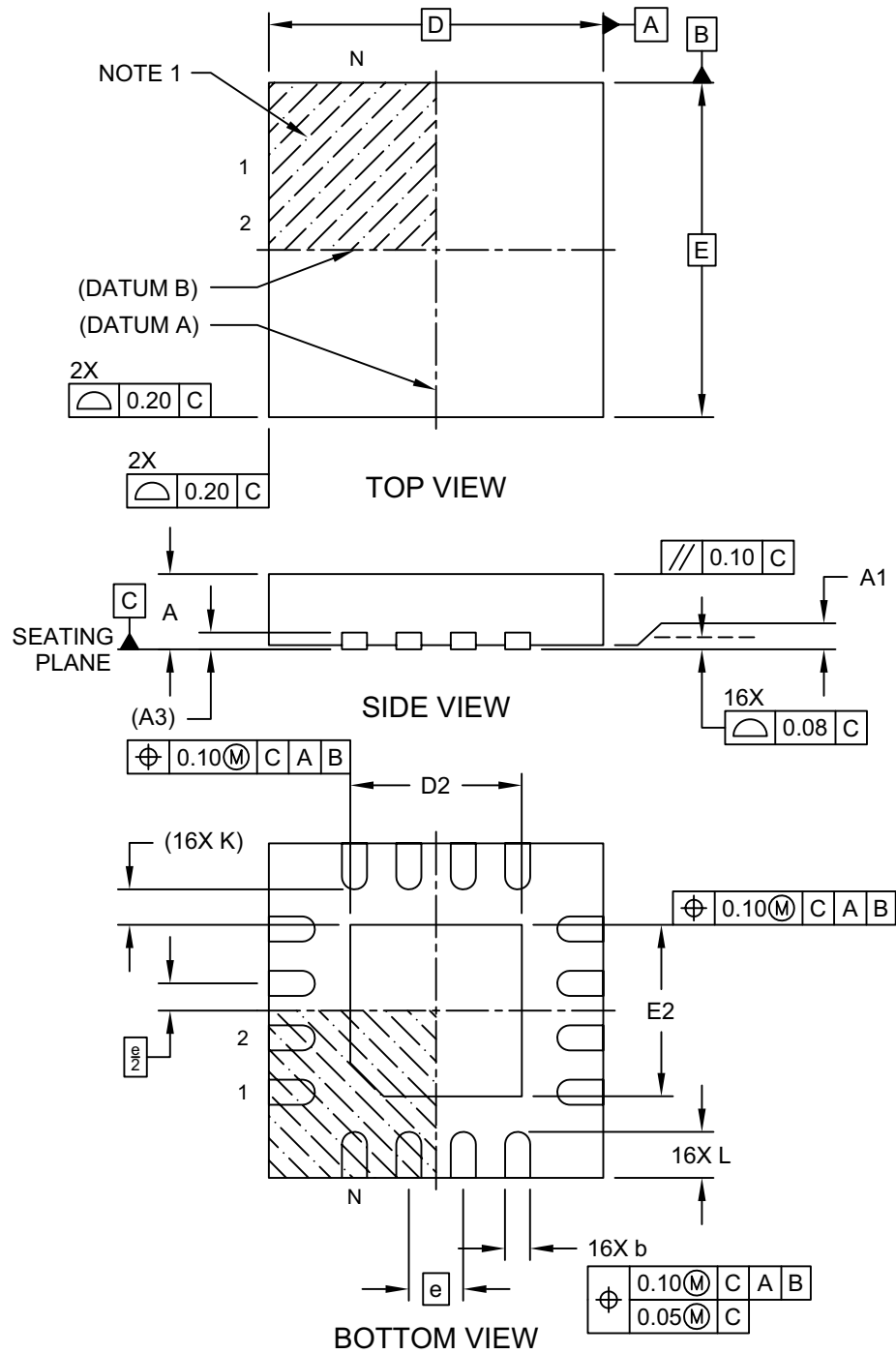
Example



Legend:	XX...X	Customer-specific information
	Y	Year code (last digit of calendar year)
	YY	Year code (last 2 digits of calendar year)
	WW	Week code (week of January 1 is week '01')
	NNN	Alphanumeric traceability code
	(e3)	Pb-free JEDEC [®] designator for Matte Tin (Sn)
	*	This package is Pb-free. The Pb-free JEDEC designator ((e3)) can be found on the outer packaging for this package.
Note:	In the event the full Microchip part number cannot be marked on one line, it will be carried over to the next line, thus limiting the number of available characters for customer-specific information.	

16-Lead Plastic Quad Flat, No Lead Package (8E) - 4x4x0.9 mm Body [QFN]

Note: For the most current package drawings, please see the Microchip Packaging Specification located at <http://www.microchip.com/packaging>

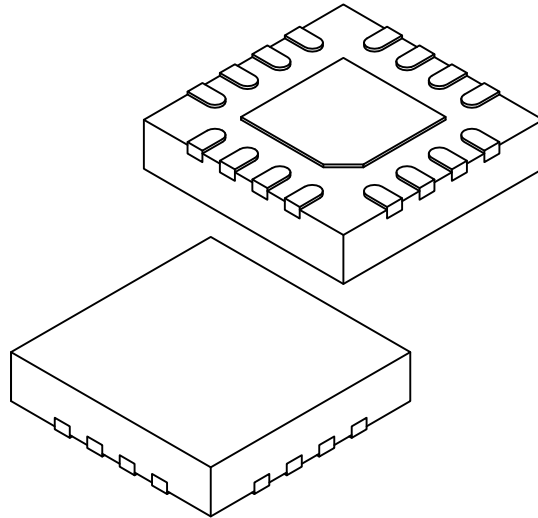


Microchip Technology Drawing C04-259B Sheet 1 of 2

EQCO30R5.D

16-Lead Plastic Quad Flat, No Lead Package (8E) - 4x4x0.9 mm Body [QFN]

Note: For the most current package drawings, please see the Microchip Packaging Specification located at <http://www.microchip.com/packaging>



Units		MILLIMETERS		
Dimension Limits		MIN	NOM	MAX
Number of Pins	N	16		
Pitch	e	0.65 BSC		
Overall Height	A	0.80	0.87	0.95
Standoff	A1	0.00	0.02	0.05
Terminal Thickness	A3	0.20 REF		
Overall Width	E	4.00 BSC		
Exposed Pad Width	E2	1.95	2.05	2.15
Overall Length	D	4.00 BSC		
Exposed Pad Length	D2	1.95	2.05	2.15
Terminal Width	b	0.25	0.30	0.35
Terminal Length	L	0.45	0.55	0.65
Terminal-to-Exposed-Pad	K	0.425 REF		

Notes:

1. Pin 1 visual index feature may vary, but must be located within the hatched area.
2. Package is saw singulated
3. Dimensioning and tolerancing per ASME Y14.5M

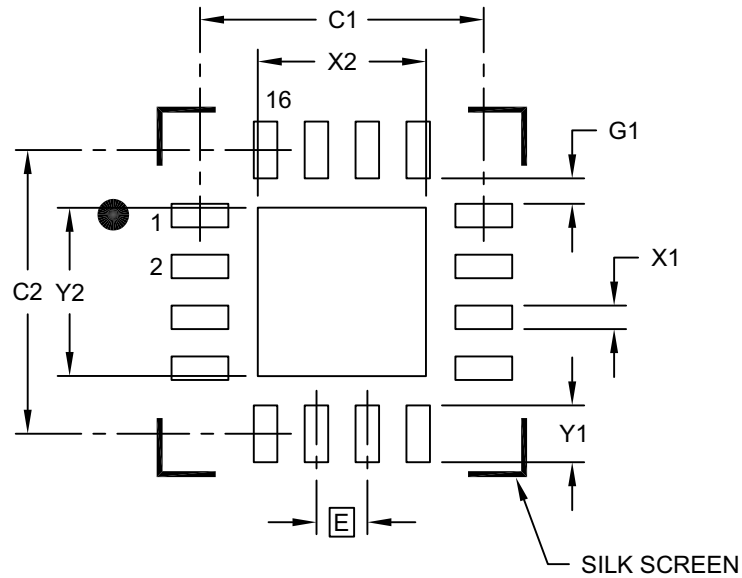
BSC: Basic Dimension. Theoretically exact value shown without tolerances.

REF: Reference Dimension, usually without tolerance, for information purposes only.

Microchip Technology Drawing C04-259B Sheet 2 of 2

16-Lead Plastic Quad Flat, No Lead Package (8E) - 4x4x0.9 mm Body [QFN]

Note: For the most current package drawings, please see the Microchip Packaging Specification located at <http://www.microchip.com/packaging>



RECOMMENDED LAND PATTERN

Dimension Limits	Units	MILLIMETERS		
		MIN	NOM	MAX
Contact Pitch	E	0.65 BSC		
Optional Center Pad Width	X2			2.15
Optional Center Pad Length	Y2			2.15
Contact Pad Spacing	C1		3.625	
Contact Pad Spacing	C2		3.625	
Contact Pad Width (X16)	X1			0.30
Contact Pad Length (X16)	Y1			0.725
Contact Pad to Center Pad (X16)	G1	0.20		

Notes:

1. Dimensioning and tolerancing per ASME Y14.5M

BSC: Basic Dimension. Theoretically exact value shown without tolerances.

Microchip Technology Drawing C04-2259A

EQCO30R5.D

APPENDIX A: REVISION HISTORY

Revision C (November 2016)

- Revised Section 1.1.3 (LFI).

Revision B (February 2016)

- Removed electrostatic discharge ratings from [Table 3-1](#).
- Minor typographical changes.

Revision A (September 2014)

This is the initial release of the document in the Microchip format. This replaces EqcoLogic document version 1v0.

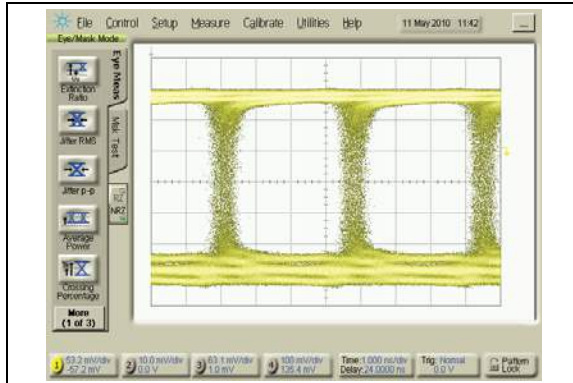
TABLE A-1: REVISION HISTORY

Version	Date	Comments
1v0	1/27/14	Finalizing document
0v2	6/27/13	Revision
0v1	11/23/11	New document

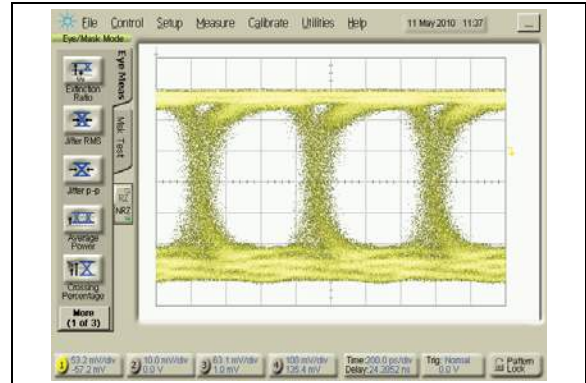
APPENDIX B: TYPICAL EQUALIZER CHARACTERISTICS

All measurements at $V_{CC} = 3.3V$, Temp = +25°C, data pattern = prbs15 (including 20 μs of each polarity of pathological pattern), measured with Belden 1694A cable.

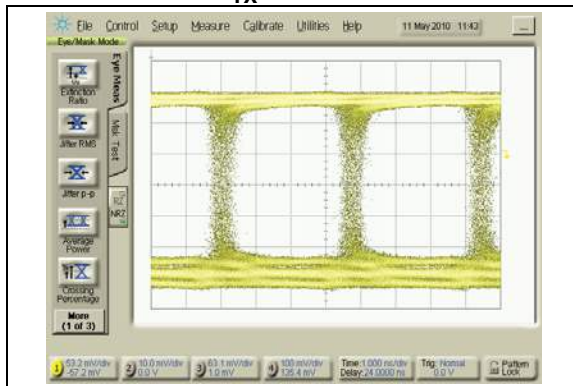
**FIGURE B-1: 270 Mbps, 410m,
 $\Delta V_{TX} = 620$ mV**



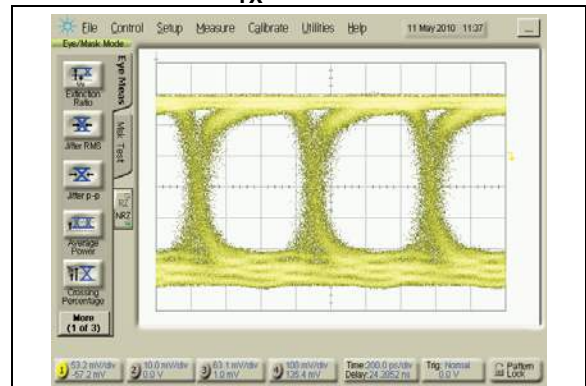
**FIGURE B-4: 1.485 Gbps, 200m,
 $\Delta V_{TX} = 620$ mV**



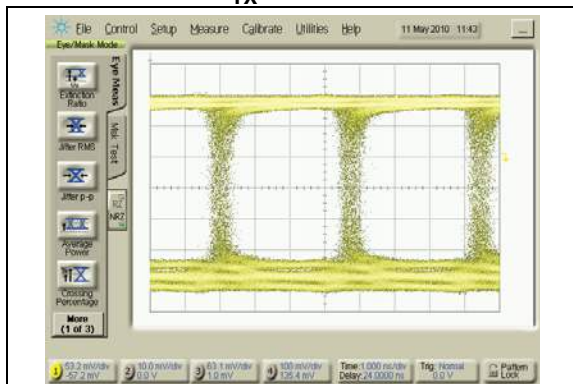
**FIGURE B-2: 270 Mbps, 410m,
 $\Delta V_{TX} = 800$ mV**



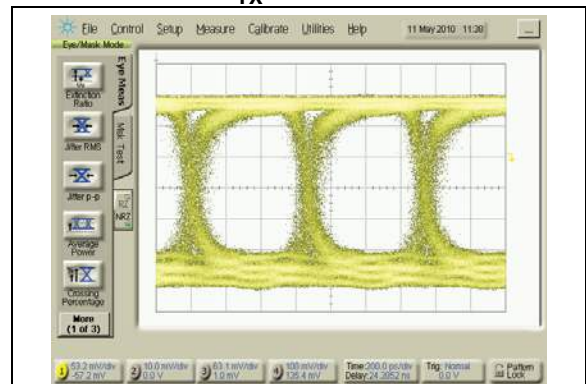
**FIGURE B-5: 1.485 Gbps, 200m,
 $\Delta V_{TX} = 800$ mV**



**FIGURE B-3: 270 Mbps, 410m,
 $\Delta V_{TX} = 980$ mV**

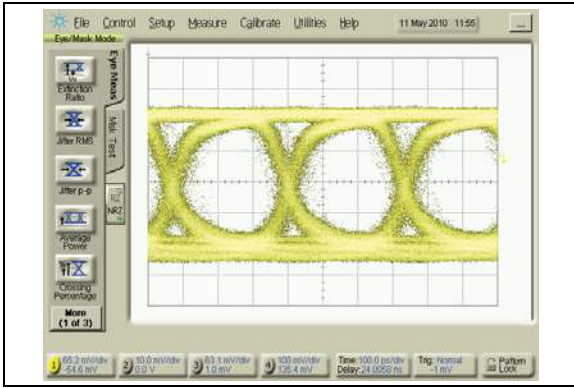


**FIGURE B-6: 1.485 Gbps, 200m,
 $\Delta V_{TX} = 980$ mV**

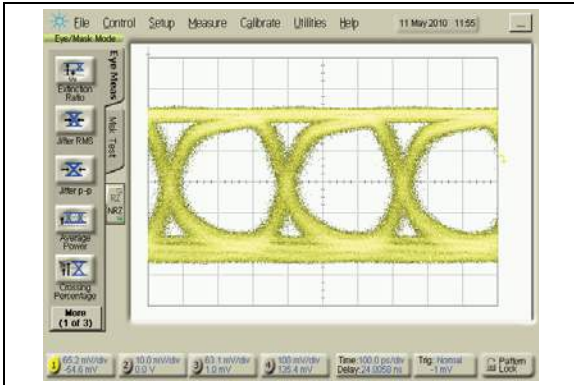


EQCO30R5.D

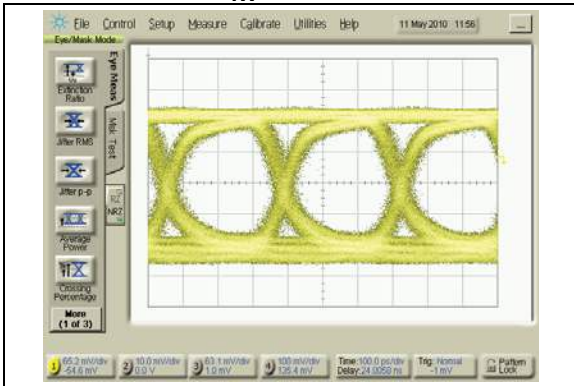
**FIGURE B-7: 2.97 Gbps, 140m,
 $\Delta V_{TX} = 620 \text{ mV}$**



**FIGURE B-8: 2.97 Gbps, 140m,
 $\Delta V_{TX} = 800 \text{ mV}$**



**FIGURE B-9: 2.97 Gbps, 140m,
 $\Delta V_{TX} = 980 \text{ mV}$**



THE MICROCHIP WEBSITE

Microchip provides online support via our website at www.microchip.com. This website is used as a means to make files and information easily available to customers. Accessible by using your favorite Internet browser, the website contains the following information:

- **Product Support** – Data sheets and errata, application notes and sample programs, design resources, user's guides and hardware support documents, latest software releases and archived software
- **General Technical Support** – Frequently Asked Questions (FAQs), technical support requests, online discussion groups, Microchip consultant program member listing
- **Business of Microchip** – Product selector and ordering guides, latest Microchip press releases, listing of seminars and events, listings of Microchip sales offices, distributors and factory representatives

CUSTOMER CHANGE NOTIFICATION SERVICE

Microchip's customer notification service helps keep customers current on Microchip products. Subscribers will receive e-mail notification whenever there are changes, updates, revisions or errata related to a specified product family or development tool of interest.

To register, access the Microchip website at www.microchip.com. Under "Support", click on "Customer Change Notification" and follow the registration instructions.

CUSTOMER SUPPORT

Users of Microchip products can receive assistance through several channels:

- Distributor or Representative
- Local Sales Office
- Field Application Engineer (FAE)
- Technical Support

Customers should contact their distributor, representative or field application engineer (FAE) for support. Local sales offices are also available to help customers. A listing of sales offices and locations is included in the back of this document.

Technical support is available through the website at: <http://microchip.com/support>

EQCO30R5.D

PRODUCT IDENTIFICATION SYSTEM

To order parts, including industrial, or obtain information, for e.g., on pricing or delivery, refer to the factory or the listed sales office.

<u>PART NO.</u> Device	<u>I</u> Temp. Range	<u>RM</u> Radio Module	<u>XXX</u> Firmware Revision Number	Examples:
Device: EQCO30R5.D	Temperature Range: I = -40°C to +85°C (Industrial temperature)			a) EQCO30R5.D = Industrial temperature, 16-Lead QFN Tube packaging
Package: TRAY = Tray (Blank) = Tube				b) EQCO30R5.D-TRAY = Industrial temperature, 16-Lead QFN Tray packaging

Note the following details of the code protection feature on Microchip devices:

- Microchip products meet the specification contained in their particular Microchip Data Sheet.
- Microchip believes that its family of products is one of the most secure families of its kind on the market today, when used in the intended manner and under normal conditions.
- There are dishonest and possibly illegal methods used to breach the code protection feature. All of these methods, to our knowledge, require using the Microchip products in a manner outside the operating specifications contained in Microchip's Data Sheets. Most likely, the person doing so is engaged in theft of intellectual property.
- Microchip is willing to work with the customer who is concerned about the integrity of their code.
- Neither Microchip nor any other semiconductor manufacturer can guarantee the security of their code. Code protection does not mean that we are guaranteeing the product as “unbreakable.”

Code protection is constantly evolving. We at Microchip are committed to continuously improving the code protection features of our products. Attempts to break Microchip's code protection feature may be a violation of the Digital Millennium Copyright Act. If such acts allow unauthorized access to your software or other copyrighted work, you may have a right to sue for relief under that Act.

Information contained in this publication regarding device applications and the like is provided only for your convenience and may be superseded by updates. It is your responsibility to ensure that your application meets with your specifications. MICROCHIP MAKES NO REPRESENTATIONS OR WARRANTIES OF ANY KIND WHETHER EXPRESS OR IMPLIED, WRITTEN OR ORAL, STATUTORY OR OTHERWISE, RELATED TO THE INFORMATION, INCLUDING BUT NOT LIMITED TO ITS CONDITION, QUALITY, PERFORMANCE, MERCHANTABILITY OR FITNESS FOR PURPOSE. Microchip disclaims all liability arising from this information and its use. Use of Microchip devices in life support and/or safety applications is entirely at the buyer's risk, and the buyer agrees to defend, indemnify and hold harmless Microchip from any and all damages, claims, suits, or expenses resulting from such use. No licenses are conveyed, implicitly or otherwise, under any Microchip intellectual property rights unless otherwise stated.

Microchip received ISO/TS-16949:2009 certification for its worldwide headquarters, design and wafer fabrication facilities in Chandler and Tempe, Arizona; Gresham, Oregon and design centers in California and India. The Company's quality system processes and procedures are for its PIC® MCUs and dsPIC® DSCs, KEELoC® code hopping devices, Serial EEPROMs, microperipherals, nonvolatile memory and analog products. In addition, Microchip's quality system for the design and manufacture of development systems is ISO 9001:2000 certified.

**QUALITY MANAGEMENT SYSTEM
CERTIFIED BY DNV
= ISO/TS 16949 =**

Trademarks

The Microchip name and logo, the Microchip logo, AnyRate, AVR, AVR logo, AVR Freaks, BeaconThings, BitCloud, CryptoMemory, CryptoRF, dsPIC, FlashFlex, flexPWR, Heldo, JukeBlox, KEELoQ, KEELoQ logo, Kleer, LANCheck, LINK MD, maXStylus, maXTouch, MediaLB, megaAVR, MOST, MOST logo, MPLAB, OptoLyzer, PIC, picoPower, PICSTART, PIC32 logo, Prochip Designer, QTouch, RightTouch, SAM-BA, SpyNIC, SST, SST Logo, SuperFlash, tinyAVR, UNI/O, and XMEGA are registered trademarks of Microchip Technology Incorporated in the U.S.A. and other countries.

ClockWorks, The Embedded Control Solutions Company, EtherSynch, Hyper Speed Control, HyperLight Load, IntelliMOS, mTouch, Precision Edge, and Quiet-Wire are registered trademarks of Microchip Technology Incorporated in the U.S.A.

Adjacent Key Suppression, AKS, Analog-for-the-Digital Age, Any Capacitor, AnyIn, AnyOut, BodyCom, chipKIT, chipKIT logo, CodeGuard, CryptoAuthentication, CryptoCompanion, CryptoController, dsPICDEM, dsPICDEM.net, Dynamic Average Matching, DAM, ECAN, EtherGREEN, In-Circuit Serial Programming, ICSP, Inter-Chip Connectivity, JitterBlocker, KleerNet, KleerNet logo, Mindi, MiWi, motorBench, MPASM, MPF, MPLAB Certified logo, MPLIB, MPLINK, MultiTRAK, NetDetach, Omniscient Code Generation, PICDEM, PICDEM.net, PICKit, PICtail, PureSilicon, QMatrix, RightTouch logo, REAL ICE, Ripple Blocker, SAM-ICE, Serial Quad I/O, SMART-I.S., SQI, SuperSwitcher, SuperSwitcher II, Total Endurance, TSHARC, USBCheck, VariSense, ViewSpan, WiperLock, Wireless DNA, and ZENA are trademarks of Microchip Technology Incorporated in the U.S.A. and other countries.

SQTP is a service mark of Microchip Technology Incorporated in the U.S.A.

Silicon Storage Technology is a registered trademark of Microchip Technology Inc. in other countries.

GestIC is a registered trademark of Microchip Technology Germany II GmbH & Co. KG, a subsidiary of Microchip Technology Inc., in other countries.

All other trademarks mentioned herein are property of their respective companies.

© 2011-2016, Microchip Technology Incorporated, All Rights Reserved.

ISBN: 978-1-5224-1148-2



MICROCHIP

Worldwide Sales and Service

AMERICAS

Corporate Office

2355 West Chandler Blvd.
Chandler, AZ 85224-6199
Tel: 480-792-7200
Fax: 480-792-7277
Technical Support:
<http://www.microchip.com/support>

Web Address:

www.microchip.com

Atlanta

Duluth, GA
Tel: 678-957-9614
Fax: 678-957-1455

Austin, TX

Tel: 512-257-3370

Boston

Westborough, MA
Tel: 774-760-0087
Fax: 774-760-0088

Chicago

Itasca, IL
Tel: 630-285-0071
Fax: 630-285-0075

Dallas

Addison, TX
Tel: 972-818-7423
Fax: 972-818-2924

Detroit

Novi, MI
Tel: 248-848-4000

Houston, TX

Tel: 281-894-5983

Indianapolis

Noblesville, IN
Tel: 317-773-8323
Fax: 317-773-5453
Tel: 317-536-2380

Los Angeles

Mission Viejo, CA
Tel: 949-462-9523
Fax: 949-462-9608
Tel: 951-273-7800

Raleigh, NC

Tel: 919-844-7510

New York, NY

Tel: 631-435-6000

San Jose, CA

Tel: 408-735-9110
Tel: 408-436-4270

Canada - Toronto

Tel: 905-695-1980
Fax: 905-695-2078

ASIA/PACIFIC

Asia Pacific Office

Suites 3707-14, 37th Floor
Tower 6, The Gateway
Harbour City, Kowloon

Hong Kong

Tel: 852-2943-5100
Fax: 852-2401-3431

Australia - Sydney

Tel: 61-2-9868-6733
Fax: 61-2-9868-6755

China - Beijing

Tel: 86-10-8569-7000
Fax: 86-10-8528-2104

China - Chengdu

Tel: 86-28-8665-5511
Fax: 86-28-8665-7889

China - Chongqing

Tel: 86-23-8980-9588
Fax: 86-23-8980-9500

China - Dongguan

Tel: 86-769-8702-9880

China - Guangzhou

Tel: 86-20-8755-8029

China - Hangzhou

Tel: 86-571-8792-8115
Fax: 86-571-8792-8116

China - Hong Kong SAR

Tel: 852-2943-5100
Fax: 852-2401-3431

China - Nanjing

Tel: 86-25-8473-2460
Fax: 86-25-8473-2470

China - Qingdao

Tel: 86-532-8502-7355
Fax: 86-532-8502-7205

China - Shanghai

Tel: 86-21-3326-8000
Fax: 86-21-3326-8021

China - Shenyang

Tel: 86-24-2334-2829
Fax: 86-24-2334-2393

China - Shenzhen

Tel: 86-755-8864-2200
Fax: 86-755-8203-1760

China - Wuhan

Tel: 86-27-5980-5300
Fax: 86-27-5980-5118

China - Xian

Tel: 86-29-8833-7252
Fax: 86-29-8833-7256

ASIA/PACIFIC

China - Xiamen

Tel: 86-592-2388138
Fax: 86-592-2388130

China - Zhuhai

Tel: 86-756-3210040
Fax: 86-756-3210049

India - Bangalore

Tel: 91-80-3090-4444
Fax: 91-80-3090-4123

India - New Delhi

Tel: 91-11-4160-8631
Fax: 91-11-4160-8632

India - Pune

Tel: 91-20-3019-1500

Japan - Osaka

Tel: 81-6-6152-7160
Fax: 81-6-6152-9310

Japan - Tokyo

Tel: 81-3-6880-3770
Fax: 81-3-6880-3771

Korea - Daegu

Tel: 82-53-744-4301
Fax: 82-53-744-4302

Korea - Seoul

Tel: 82-2-554-7200
Fax: 82-2-558-5932 or
82-2-558-5934

Malaysia - Kuala Lumpur

Tel: 60-3-6201-9857
Fax: 60-3-6201-9859

Malaysia - Penang

Tel: 60-4-227-8870
Fax: 60-4-227-4068

Philippines - Manila

Tel: 63-2-634-9065
Fax: 63-2-634-9069

Singapore

Tel: 65-6334-8870
Fax: 65-6334-8850

Taiwan - Hsin Chu

Tel: 886-3-5778-366
Fax: 886-3-5770-955

Taiwan - Kaohsiung

Tel: 886-7-213-7830

Taiwan - Taipei

Tel: 886-2-2508-8600
Fax: 886-2-2508-0102

Thailand - Bangkok

Tel: 66-2-694-1351
Fax: 66-2-694-1350

EUROPE

Austria - Wels

Tel: 43-7242-2244-39
Fax: 43-7242-2244-393

Denmark - Copenhagen

Tel: 45-4450-2828
Fax: 45-4485-2829

Finland - Espoo

Tel: 358-9-4520-820

France - Paris

Tel: 33-1-69-53-63-20
Fax: 33-1-69-30-90-79

France - Saint Cloud

Tel: 33-1-30-60-70-00

Germany - Garching

Tel: 49-8931-9700

Germany - Haan

Tel: 49-2129-3766400

Germany - Heilbronn

Tel: 49-7131-67-3636

Germany - Karlsruhe

Tel: 49-721-625370

Germany - Munich

Tel: 49-89-627-144-0
Fax: 49-89-627-144-44

Germany - Rosenheim

Tel: 49-8031-354-560

Israel - Ra'anana

Tel: 972-9-744-7705

Italy - Milan

Tel: 39-0331-742611
Fax: 39-0331-466781

Italy - Padova

Tel: 39-049-7625286

Netherlands - Drunen

Tel: 31-416-690399
Fax: 31-416-690340

Norway - Trondheim

Tel: 47-7289-7561

Poland - Warsaw

Tel: 48-22-3325737

Romania - Bucharest

Tel: 40-21-407-87-50

Spain - Madrid

Tel: 34-91-708-08-90
Fax: 34-91-708-08-91

Sweden - Gothenberg

Tel: 46-31-704-60-40

Sweden - Stockholm

Tel: 46-8-5090-4654

UK - Wokingham

Tel: 44-118-921-5800
Fax: 44-118-921-5820