

PRODUCT NUMBER (SEE NOTE 2)	CONTACT PLATING		ROHS COMPATIBILITY
	SEPARABLE INTERFACE	PRESS-FIT TAIL	
10124635-001		TIN-LEAD OVER NICKEL	N/A
10124635-001LF		MATTE TIN OVER NICKEL	SEE NOTE 8

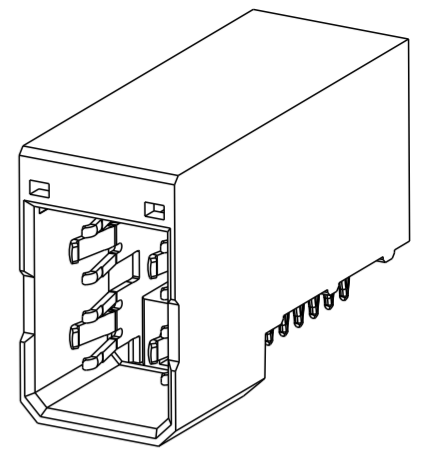

SCALE 2:1

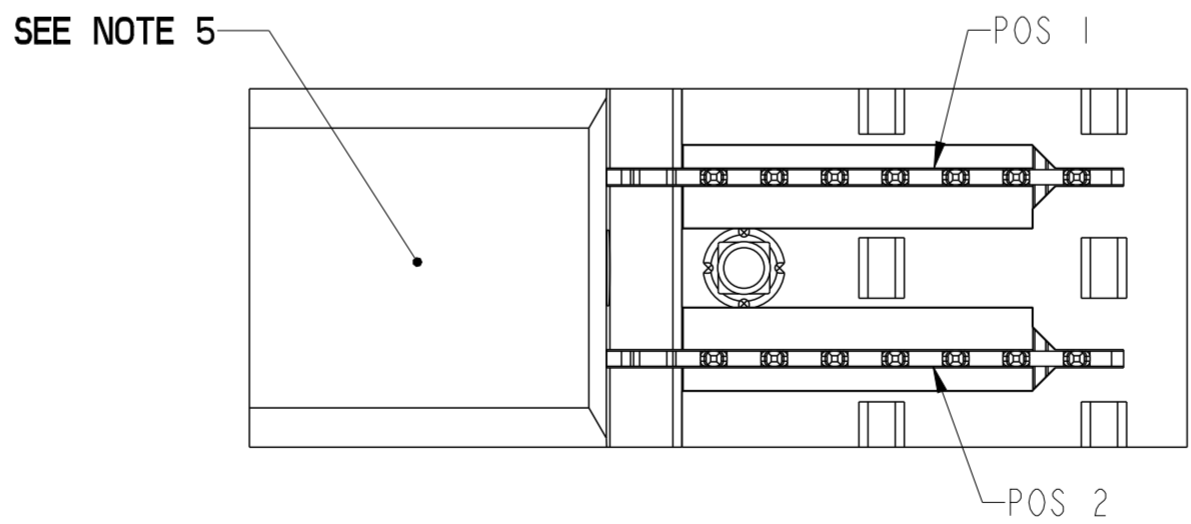
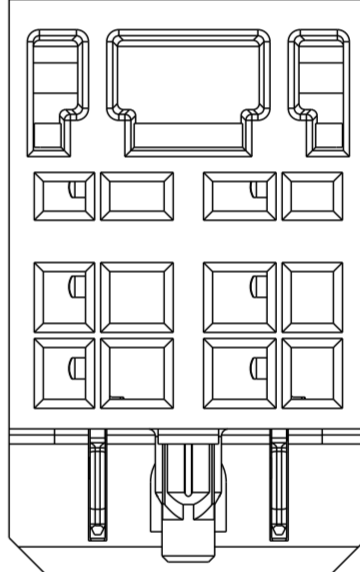
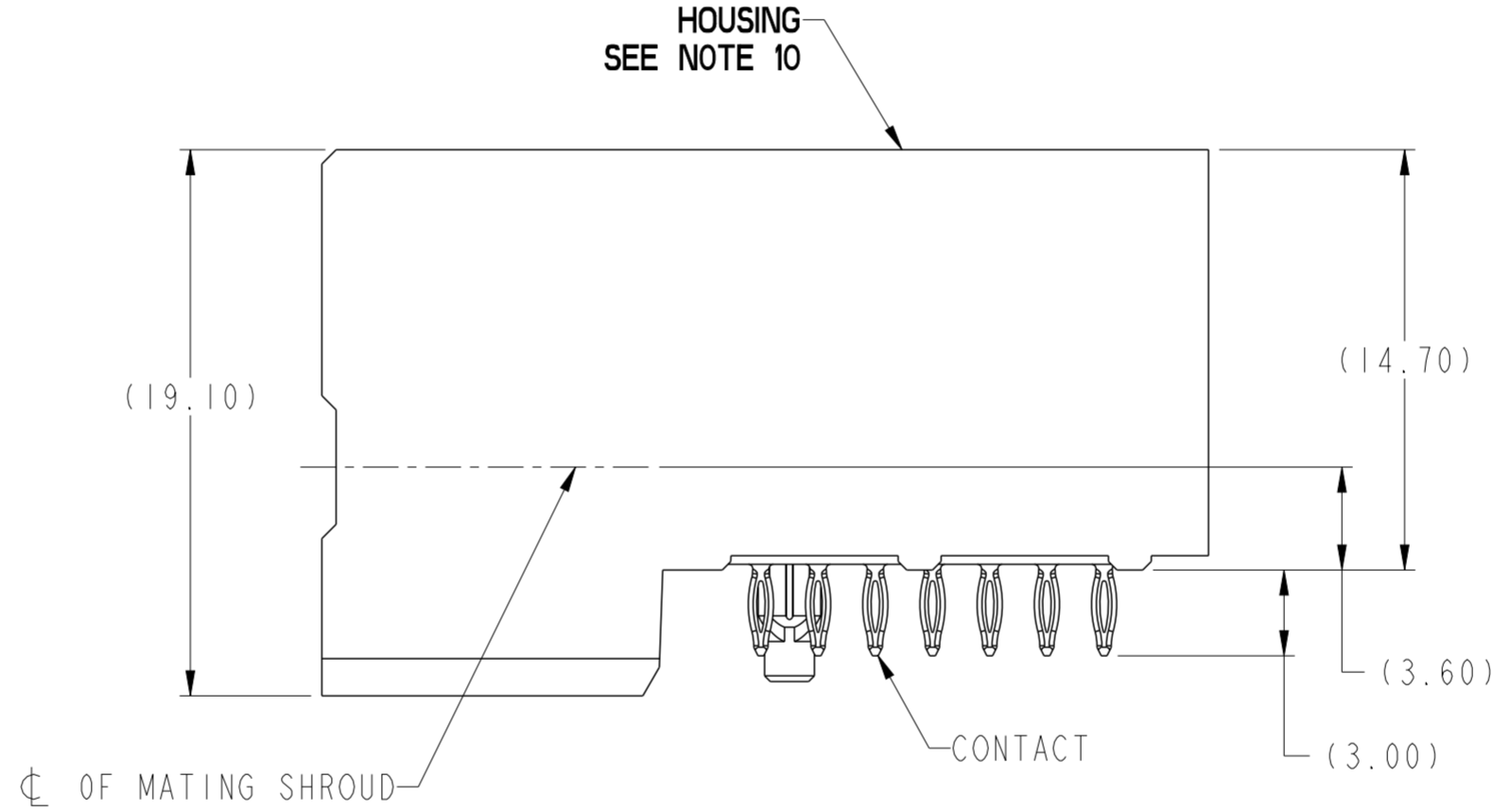
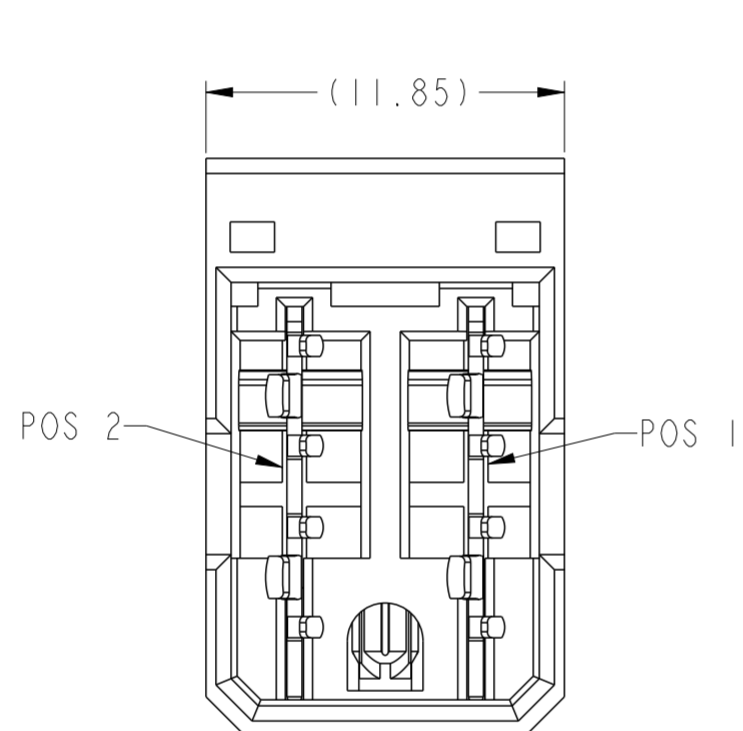
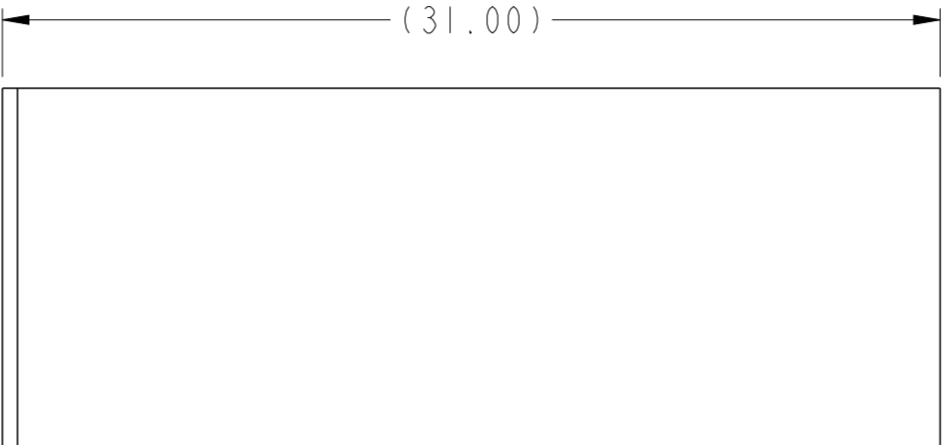

spec ref	GS-12-220	dr	S Paulgandian	2013/03/08	projection	MM	size	A2	scale	4:1
tolerance std	ASME Y14.5	eng	Suzie Nah	2013/09/06	chr	-	ecn no	ELX-S-15671-1	rel level	Released
surface	✓	appr	Chen-Hong Tan	2013/09/19	product family	2mm High Power	cat. no.	10124635	rev	B
ASME Y14.5	linear	0.X	±.3	angular	0°	±2°	www.fci.com	Product - Customer Drw	sheet 1 of 2	

PDS: Rev :B

STATUS:Released

Printed: Sep 20, 2013

Copyright FCI. FCI

TOP LAYER DESCRIPTION	TABLE I PLATED THROUGH-HOLE REQUIREMENTS							
	DRILLED HOLE DIAMETER	COPPER THICKNESS	TIN-LEAD THICKNESS	NICKEL THICKNESS	GOLD THICKNESS	TIN THICKNESS	SILVER THICKNESS	FINISHED HOLE DIAMETER (DIM"A")
TIN-LEAD	0.81-0.86 (0.85 DRILL)	0.025 - 0.050	0.005 - 0.015	--	--	--	--	0.65 - 0.80
IMMERSION TIN	0.81-0.86 (0.85 DRILL)	0.025 - 0.050	--	--	--	0.9 - 1.5um	--	0.70 - 0.80
IMMERSION SILVER	0.81-0.86 (0.85 DRILL)	0.025 - 0.050	--	--	--	--	0.15 - 0.65um	0.70 - 0.80
COPPER (SEE NOTE 11)	0.81-0.86 (0.85 DRILL)	0.025 - 0.050	--	--	--	--	--	0.70 - 0.80
GOLD	0.81-0.86 (0.85 DRILL)	0.025 - 0.050	--	0.003 - 0.007	FLASH UP TO 0.0002	--	--	0.69 - 0.80

- NOTES:
- CONNECTOR MATERIALS:  
HOUSING: HIGH TEMPERATURE THERMOPLASTIC, BLACK  
UL 94V-0 COMPLIANT  
CONTACT: HIGH PERFORMANCE COPPER ALLOY
  - "LF" SUFFIX DENOTES "LEAD-FREE"
  - PRODUCT SPECIFICATION: GS-12-220
  - APPLICATION SPECIFICATION: GS-20-023
  - PRODUCT MARKING (PRODUCT NUMBER & LOT CODE) ON HOUSING.
  - MINIMUM NOMINAL PCB THICKNESS: 1.6mm
  - REFER TO CUSTOMER DRAWING SKI0035911 FOR INFORMATION REGARDING PCB LAYOUT OF POWER AND GUIDE MODULES RELATIVE TO SIGNAL MODULES.
  - PRODUCT MEETS EUROPEAN UNION DIRECTIVES AND OTHER COUNTRY REGULATIONS AS DESCRIBED IN FCI SPECIFICATION GS-22-008.
  - PACKAGING MEETS FCI SPECIFICATION GS-14-920.
  - HOUSING COMPONENT WILL WITHSTAND EXPOSURE TO 260°C PEAK TEMPERATURE FOR 60 SECONDS IN A CONVECTION, INFRA-RED, OR VAPOR PHASE REFLOW OVEN.
  - COPPER PLATING THICKNESS IN CENTER OF VIA HOLE CAN BE NO MORE THAN 0.003 LESS THAN OTHER AREAS.
  - A  $\triangle$  SYMBOL WILL BE NEXT TO ANY DIMENSION, VIEW, OR NOTE WHICH HAS BEEN MODIFIED WITH THE CURRENT DRAWING REVISION

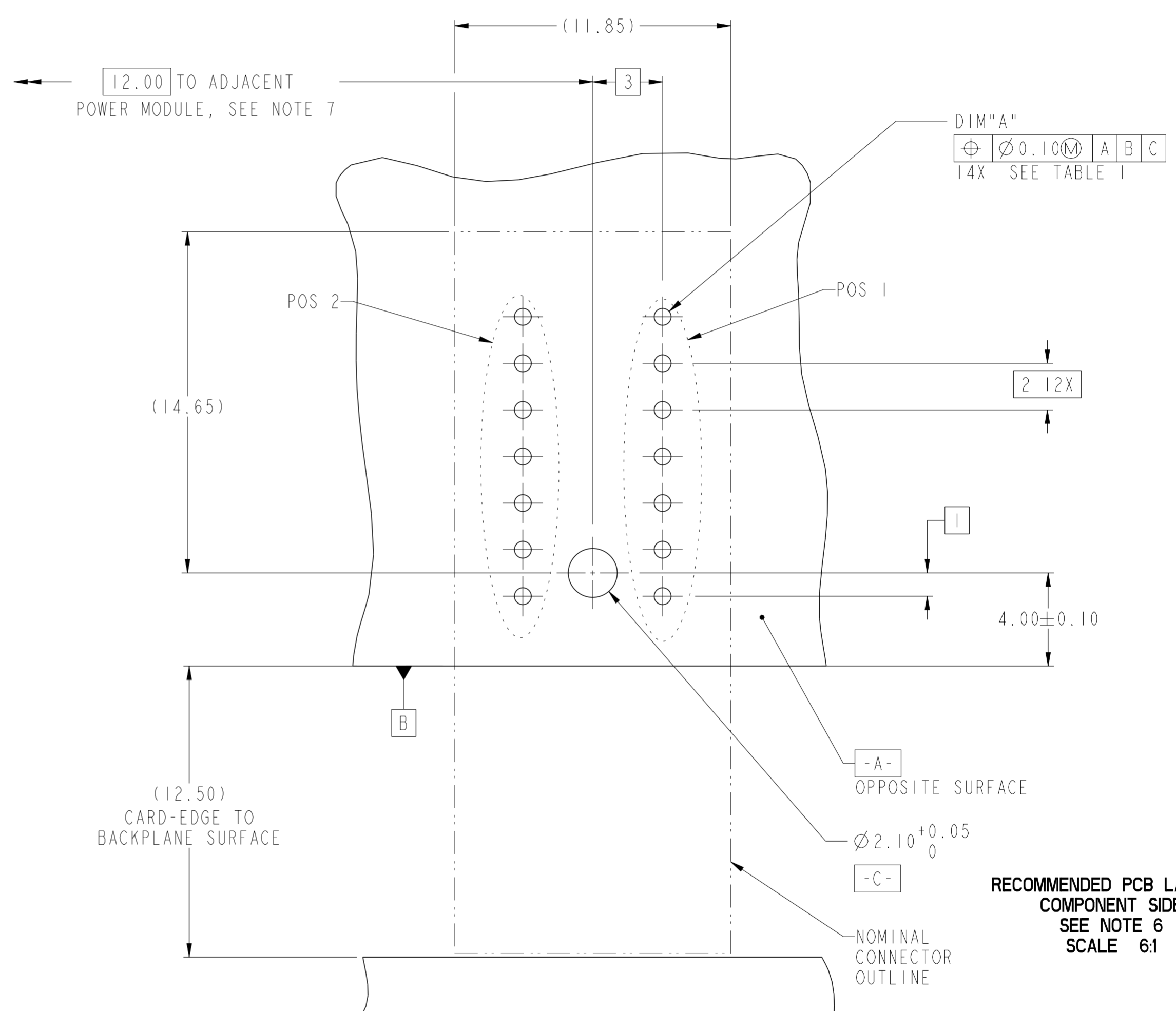

RECOMMENDED PCB LAYOUT,  
COMPONENT SIDE  
SEE NOTE 6  
SCALE 6:1

spec ref	GS-12-220	dr	S Paulgandian	2013/03/08	projection	MM	size	A2	scale	1:1
tolerance std	ASME Y14.5	eng	Suzie Nah	2013/09/06	chr	-	ecn no	ELX-S-15671-1	rel level	Released
surface	✓	appr	Chen-Hong Tan	2013/09/19	product family	2mm High Power	dwg no	10124635	rev	B
ASME Y14.5	linear	0.X	±.3	0.XX	±.10	0.XXX	±.050	angular	0°	±2°

www.fci.com cat. no. - Product - Customer Drw sheet 2 of 2