

Tous droits strictement reserves. Reproduction ou communication a des tiers interdite sous quelque forme que ce soit sans autorisation ecrite du proprietaire. Propriete de c FCI. Droits de reproduction FCI.

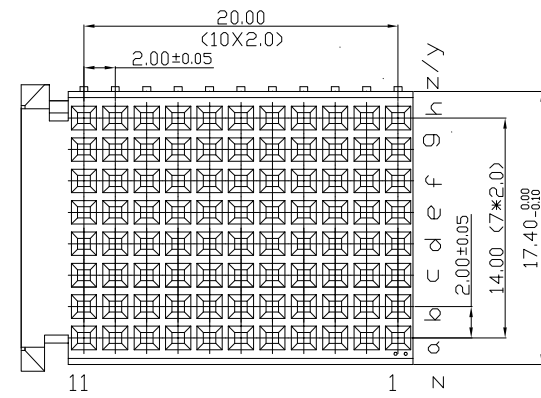

All rights strictly reserved. Reproduction or issue to third parties in any form whatever is not permitted without written authority from the proprietor. Property of FCI. Copyright FCI.

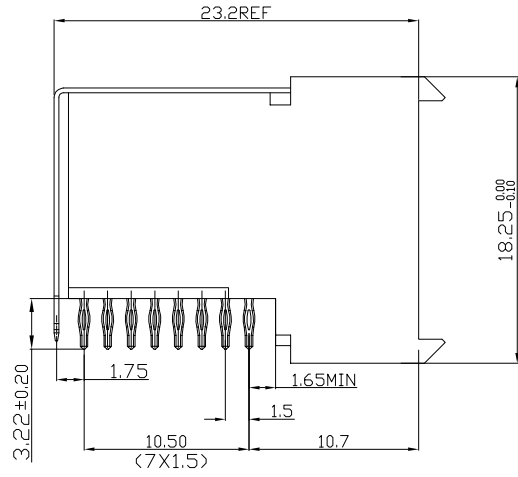

**PERFORMANCE CHARACTERISTICS**  
 CURRENT RATING 1.5A AT 20°C (FULLY LOADED)  
 1 A AT 70°C (FULLY LOADED)  
 RATED VOLTAGE : 500 V AC (CONT /CONT)  
 OPERATING TEMPERATURE : -55°C TO 125°C  
 CONTACT RESISTANCE 20 MΩ MAX  
 INSERTION FORCE : 0.75N MAX/CONT  
 EXTRACTION FORCE : 0.15N MIN/CONT  
 INSULATION RESISTANCE : 10<sup>4</sup> MΩ MIN

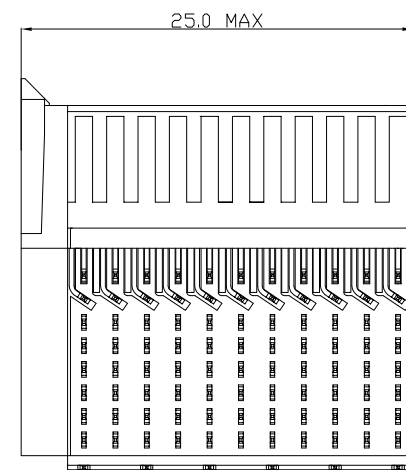
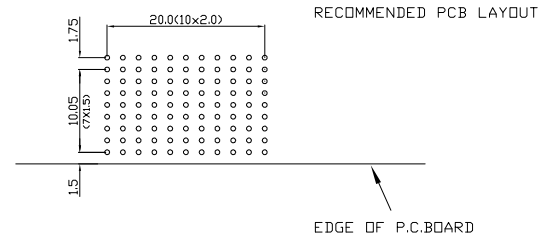

- NOTES**
- LEAD FREE INDICATOR (LF=LEAD FREE)  
 PERFORMANCE LEVEL INDICATOR (REF. DWG NO.BSC: 201844.003)
  - THIS PRODUCT IS CSA APPROVED. THIS PRODUCT IS UL RECOGNIZED.
  - FOR RECOMMENDED PTH DIMENSIONS REFER DRAWING : BSA.201572.001
  - THIS PRODUCT (LF) MEETS EUROPEAN UNION DIRECTIVES AND OTHER COUNTRY REGULATIONS AS DESCRIBED IN GS-22-008

rev	ecn no	dr	date
A	CONVERSION REVISION 01	KN	14-09-01
B	DG05-0381	Kasor	10-10-05
C	DG07-0362	Kasor	05-09-07
D	DG10-0110	NZ	05-30-10

www.fciconnect.com		tolerance 1DEC ±0.2 1DEC 2DEC ±0.1 2DEC ANGLES ±1° HOEKEN	projection 	MM 
Dr	N.OTTO	16-06-99	Product family	MILLIPICS
Eng			Spec ref	
Chr			Material	
Appr			ECN	
title	MPACS 8+2R RA RCP CONN TYPE F UPPER SHIELDED			size A4 Scale 3/1
catalog no	HM2R83PA8108----		dwg no BS,C ,202260,018 CUMSTOMER	Rev. D sheet 1 of 1