



# MOTOROLA

*Communications and Advanced  
Consumer Technologies Group*

Order this document by  
MCF5202/D

## MCF5202

### *Product Brief*

## **MCF5202 Embedded Microprocessor**

ColdFire™ represents a revolutionary microprocessor architecture that has been optimized for embedded processing applications. ColdFire brings new levels of price and performance to cost-sensitive high-volume markets. Based on the concept of variable-length RISC technology, ColdFire combines the architectural simplicity of conventional 32-bit RISC with a memory-saving, variable-length instruction set.

Using a variable-length instruction set architecture, ColdFire RISC processors offer embedded processor designers significant system-level advantages over conventional fixed-length RISC architectures. The more dense binary code for ColdFire processors occupies less valuable memory than for any fixed-length instruction set RISC processor available. This improved code density results in systems that (1) require less memory for a given application and (2) use slower and less costly memory to achieve a given performance level.

One of the first ColdFire family members, the MCF5202 has been optimized for cost-effective performance in deeply embedded applications.

The primary features of the MCF5202 processor include the following:

- Variable-Length RISC Code Density
  - Requires less memory than fixed-length RISC equivalents
  - Uses slower memory for a given performance level than fixed-length RISCs
  - Improves effectiveness of cache memory
- Simple Instruction Set Architecture
  - Optimized for high-level language constructs
  - Designed to minimize die size
  - 16 user-visible 32-bit-wide registers
  - Supervisor / User modes for system protection
  - Vector base register to relocate exception-vector table
- Dynamic Bus Sizing
  - 32-, 16-, and 8-bit bus support
- 2-Kbyte On-Chip Unified Cache
  - High performance nonblocking cache implementation
  - Four-way set associative
- Debug Module Including Background Debug (BDM) and Real-Time Debug Support
- Low Interrupt Latency Accelerates Responsiveness In Real-Time Applications
- Full Static Design Allows Operation Down to DC for Minimizing Power Consumption
- Three-State Pin
- JTAG IEEE 1149.1
- Single Bus Clock Input
- Low-Cost 100-Pin TQFP Packaging
- Fully Supported by Industry-Leading Third-Party Tools Developers

ColdFire is a trademark of Motorola.

This document contains information on a product under development. Motorola reserves the right to change or discontinue this product without notice.

---

**SEMICONDUCTOR PRODUCT INFORMATION**

---

## OVERVIEW

Figure 1 is a block diagram of the MCF5202 processor. The following paragraphs provide an overview of the MCF5202 processor.

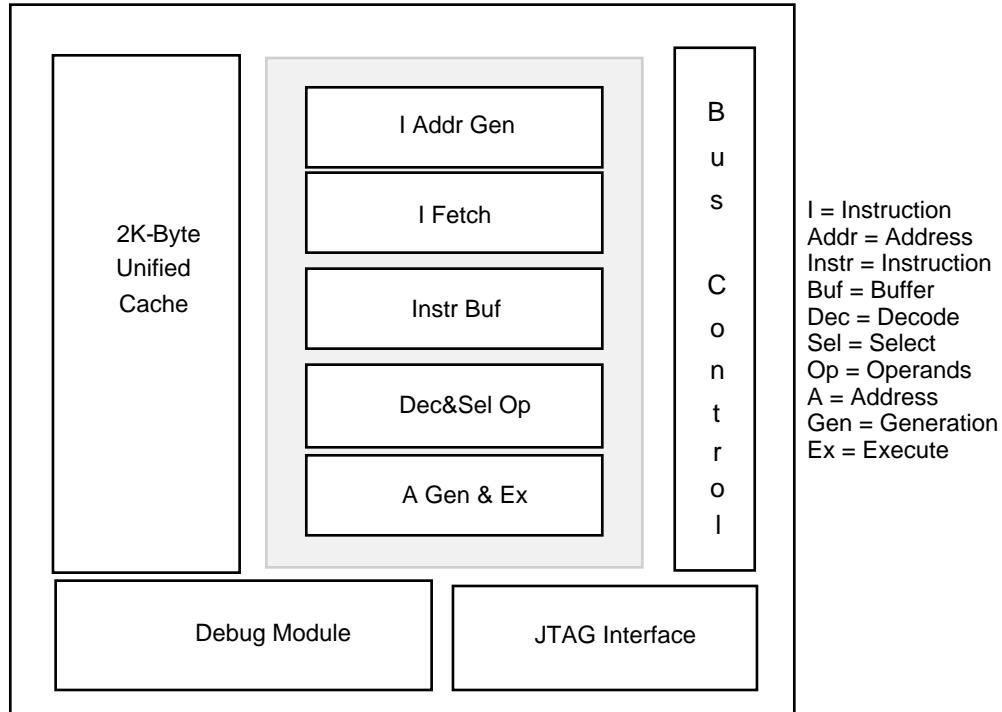

Figure 1. MCF5202 Block Diagram

### ColdFire Processor Core

The ColdFire processor core consists of two independent, decoupled pipeline structures to maximize performance while minimizing core size. The instruction fetch pipeline (IFP) is a two-stage pipeline for prefetching instructions. The prefetched instruction stream is then gated into the two-stage operand execution pipeline (OEP), which decodes the instruction, fetches the required operands and then executes the required function. Because the IFP and OEP pipelines are decoupled by an instruction buffer that serves as a FIFO queue, the IFP can prefetch instructions in advance of their actual use by the OEP, thereby minimizing time stalled waiting for instructions. The OEP is implemented in a two-stage pipeline featuring a traditional RISC datapath with a dual-read ported register file feeding an arithmetic/logic unit.

### Unified Cache

The MCF5202 processor contains a high-performance nonblocking, 2-Kbyte, four-way set-associative, unified (instruction and data) cache. The cache improves system performance by providing low latency data to the processor core. This decouples processor performance from system memory performance and increases bus availability for alternate bus masters.

The nonblocking design of the MCF5202 cache services read hits or write hits from the processor while a fill (caused by a cache allocation) is in progress. The cache can operate in either writethrough or copyback modes with no write-allocates for misses to writethrough memory. Cache design allows the MCF5202 to achieve 27MIPs performance at 33MHz.

The cache is organized as four-way set associative with 16-byte lines. Each line consists of an address tag and state information that shows line validity. In the cache, the state information indicates whether the line is invalid, valid, or dirty.

## External Bus Interface

The bus interface controller supports a high-speed, multiplexed, synchronous, external bus interface. The bus controller also provides a burst mode for fast data transfer for both reads and writes. The processor uses burst mode to update a single cache line (four long words), minimizing cache update time. The bus controller performs burst write cycles to transfer four long words to system memory, maximizing memory write performance. The bus controller operates concurrently with all of the other functional units of the device to maintain maximum system throughput.

The MCF5202 processor supports dynamic bus sizing. The MCF5202 device can access 8-, 16-, and 32-bit memory and peripherals in the system. Control signals from the system indicate to the processor the width of the memory or peripheral being accessed during the given bus cycle.

## Debug Interface

The ColdFire processor core debug interface supports real-time trace and background-debug mode.

In real-time trace, four status lines provide information on processor activity in real time (PST pins). A 4-bit wide debug data bus (DDATA) displays operand data, which helps track the machine's dynamic execution path as the change-of-flow instructions execute.

A 4-pin background debug mode (BDM) interface provides system debug. The BDM is a proper subset of the BDM interface provided on Motorola's 683xx Family of parts.

## JTAG

To help with system diagnostics and manufacturing testing, the MCF5202 processor includes dedicated user-accessible test logic that complies with the IEEE 1149.1 standard for boundary scan testability, often referred to as Joint Test Action Group (JTAG). For more information, refer to the IEEE 1149.1 standard.

## Power Consumption Management

The MCF5202 processor is very power-efficient because of static logic design. In addition to operating at slower frequencies to reduce power consumption, this processor can dynamically control power with the STOP instruction. This instruction shuts down active circuits in the processor and halts instruction execution. Processing can be resumed by resetting the part or by generating a valid interrupt.

## Pinout and Package

The MCF5202 device is supplied in a 100-pin plastic thin-quad flat-pack package with the pinout shown in Figure 2.

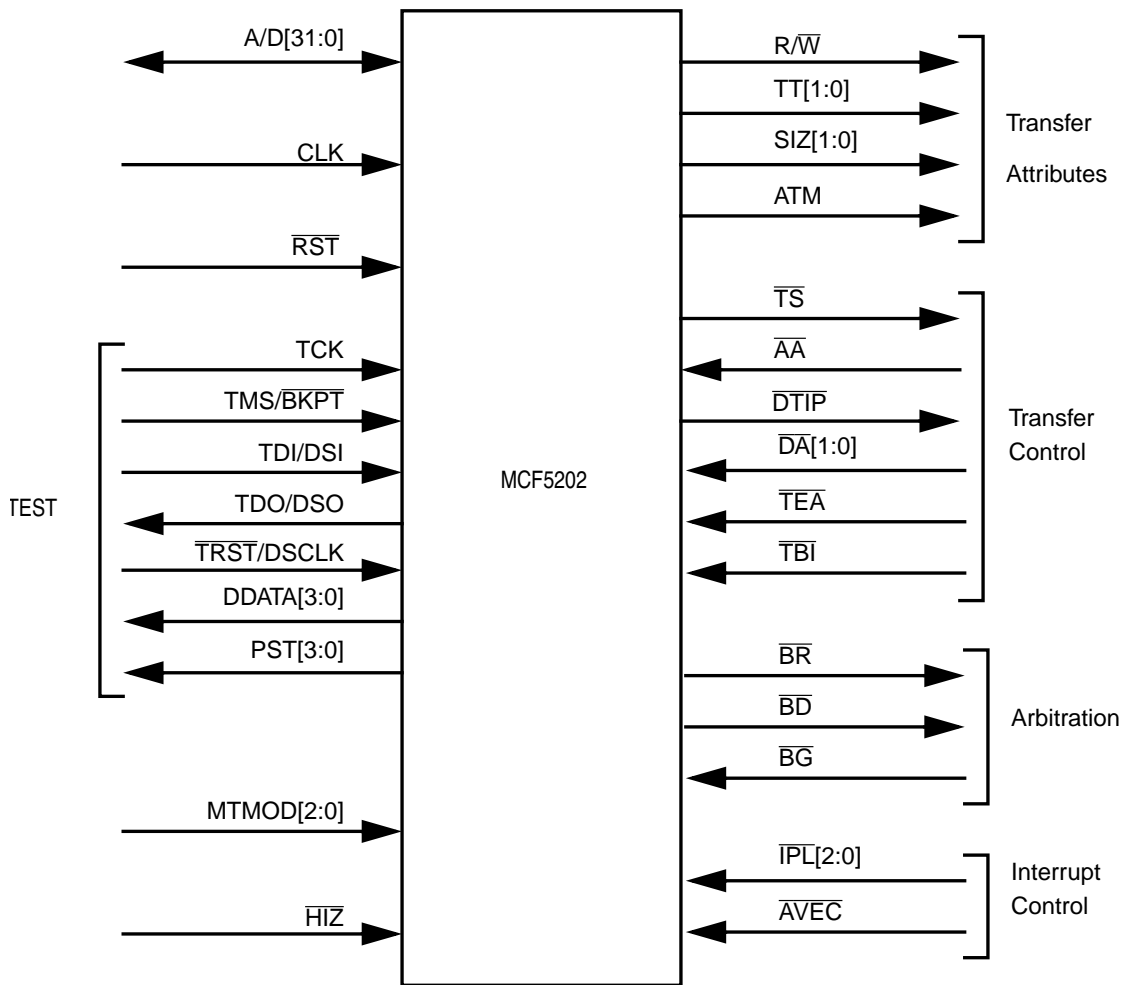

Figure 2. MCF5202/3 Block Diagram

## MORE INFORMATION

The following table identifies the packages and operating frequencies available for the MCF5202 processor.

MCF5202 Package/Frequency Availability

PACKAGE	FREQUENCY		
	16.67MHz	25MHz	33MHz
Thin Plastic Quad Flat Pack 100 lead	✓	✓	4Q96

The documents listed in the following table contain detailed information that pertain to the MCF5202 processor. These documents may be obtained from the Literature Distribution Centers at the addresses listed on the last page of this document.

### Documentation

DOCUMENT NUMBER	DOCUMENT TITLE	AVAILABILITY
MCF5202/03UM/AD	MCF5202/ User's Manual	now
MCF5200PRM/AD	ColdFire Family Programmer's Reference Manual	now

### THIRD-PARTY DEVELOPMENT TOOLS

Third-party development tools for the MCF5202 processor consist of a complete suite of compilers, debuggers, real-time operating systems, and hardware tools as shown in the tables below. Any compiler or debugger that supports the Motorola 52xx ColdFire Family can do the same for the MCF5202 processor.

COMPANY	COMPANY PHONE NUMBER	AVAILABILITY
<b>COMPILERS/DEBUGGERS</b>		
Diab Data	415-571-1700	now
Microtec	408-486-5590	1Q97
Software Development Systems	708-368-0400	now
Green Hills	805-965-6044	4Q96
Cygnus Support	415-903-1458	October 1996
<b>RTOS</b>		
Integrated Systems	408-542-1781	September 1996
Embedded System Products	713-561-9990	now
Wind River Systems	510-748-4100	now
<b>EMULATORS</b>		
Yokogawa/Orion Instruments	408-747-0440	now
Embedded Support Tools (EST)	617-828-5588	now
Lauterbach	508-620-4521	September 1996
Microtek	503-645-7333	September 1996
Huntsville Microsystems	205-881-6005	4Q96
Noral Micrologics	508-647-0103	September 1996
<b>LOGIC ANALYZERS</b>		
Hewlett-Packard	719-590-2558	now

Development Boards: A limited quantity of 5202 boards are available. Contact Carrie Richardson at 512-891-7363.

Motorola reserves the right to make changes without further notice to any products herein. Motorola makes no warranty, representation or guarantee regarding the suitability of its products for any particular purpose, nor does Motorola assume any liability arising out of the application or use of any product or circuit, and specifically disclaims any and all liability, including without limitation consequential or incidental damages. "Typical" parameters can and do vary in different applications. All operating parameters, including "Typicals" must be validated for each customer application by customer's technical experts. Motorola does not convey any license under its patent rights nor the rights of others. Motorola products are not designed, intended, or authorized for use as components in systems intended for surgical implant into the body, or other applications intended to support or sustain life, or for any other application in which the failure of the Motorola product could create a situation where personal injury or death may occur. Should Buyer purchase or use Motorola products for any such unintended or unauthorized application, Buyer shall indemnify and hold Motorola and its officers, employees, subsidiaries, affiliates, and distributors harmless against all claims, costs, damages, and expenses, and reasonable attorney fees arising out of, directly or indirectly, any claim of personal injury or death associated with such unintended or unauthorized use, even if such claim alleges that Motorola was negligent regarding the design or manufacture of the part. Motorola and  are registered trademarks of Motorola, Inc. Motorola, Inc. is an Equal Opportunity/Affirmative Action Employer.

**Literature Distribution Centers:**

USA/EUROPE: Motorola Literature Distribution; P.O. Box 20912, Arizona 85036

JAPAN: Nippon Motorola Ltd.; 4-32-1, Nishi-Gotanda, Shinagawa-ku, Tokyo 141 Japan

ASIA-PACIFIC: Motorola Semiconductors H.K. Ltd.; Silicon Harbour Center, No. 2 Dai King Street, Tai Po Industrial Estate, Tai Po, N.T., Hong Kong