

VICOR CONFIDENTIAL  
 THIS DOCUMENT AND THE DATA DISCLOSED HEREIN OR  
 HEREIN IS NOT TO BE REPRODUCED, USED OR  
 DISCLOSED IN ANY MANNER OR IN PART TO ANYONE WITHOUT  
 THE PERMISSION OF VICOR CORP.

REV.	DESCRIPTION	DATE	APPROVED
1	RELEASED PER E0230307	07/11/02	JMR
2	REVISED PER E080070	01/11/08	REJH
3	REVISED PER E091753	09/29/09	REJH
4	REVISED PER E092276	12/30/09	REJH
5	REVISED PER E120065	01/20/12	KUK

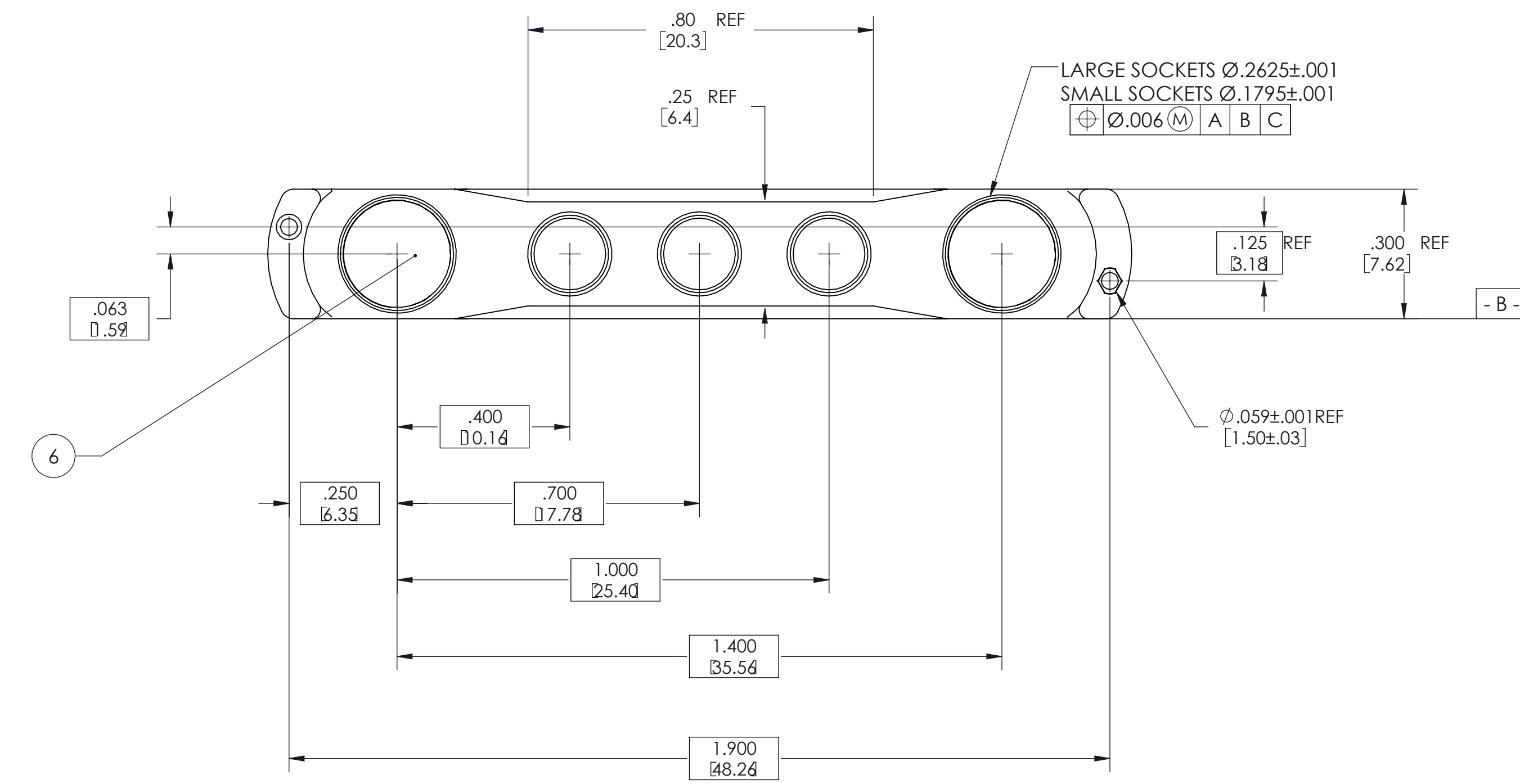
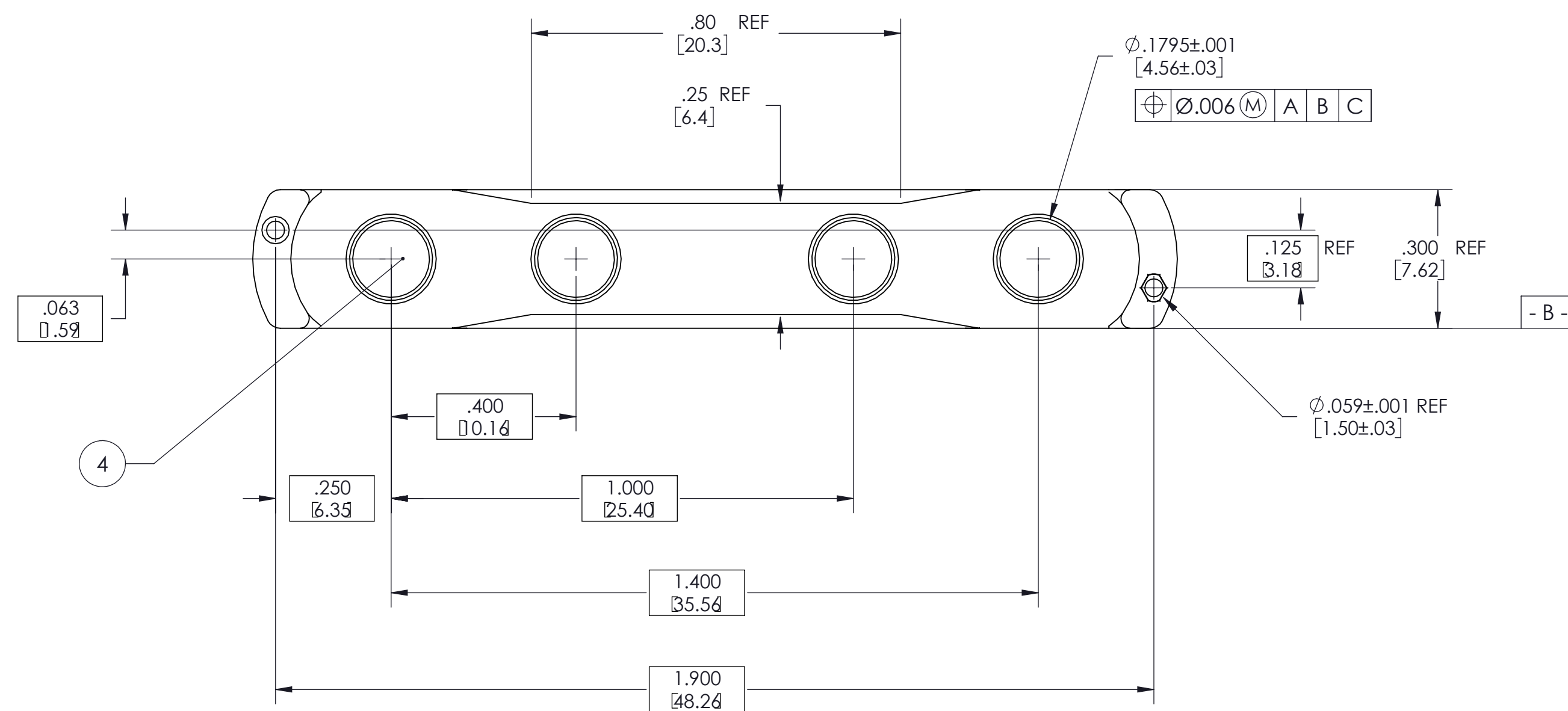
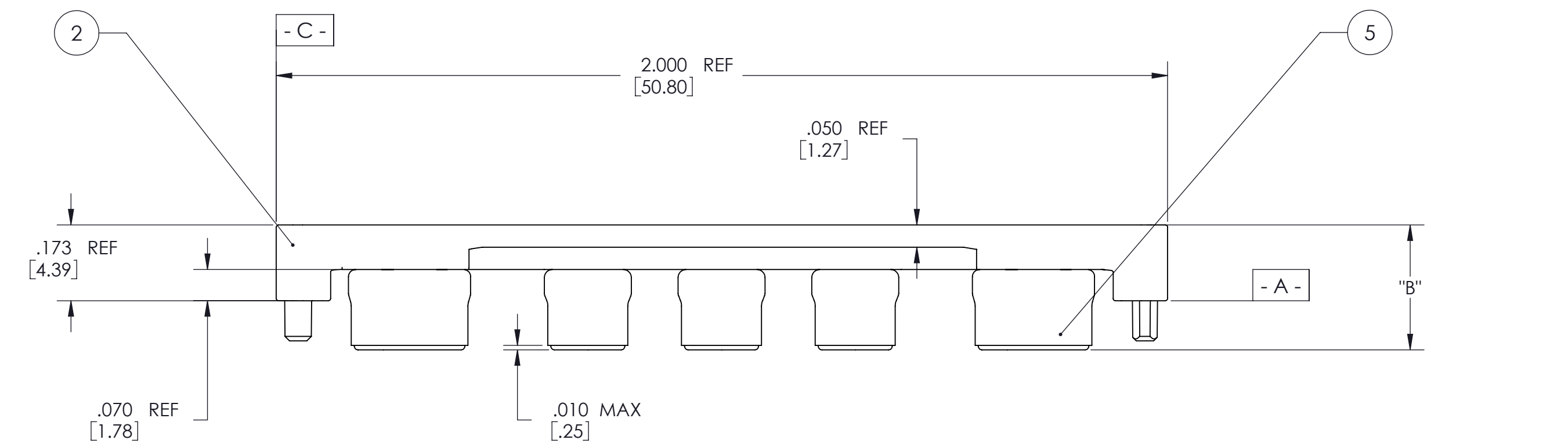
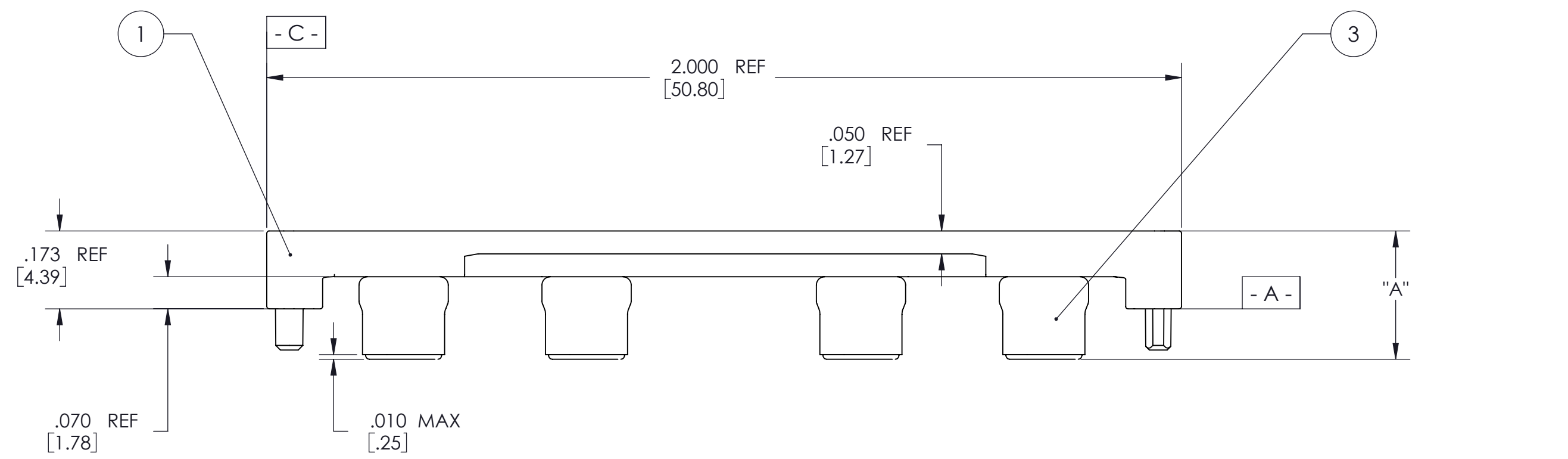
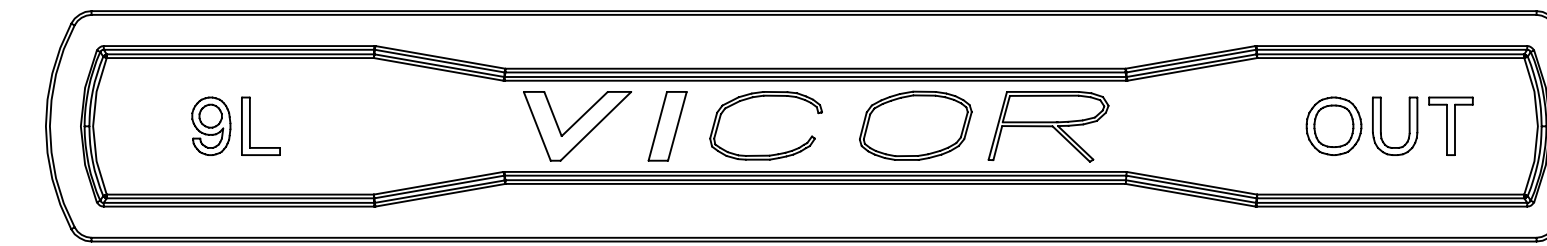
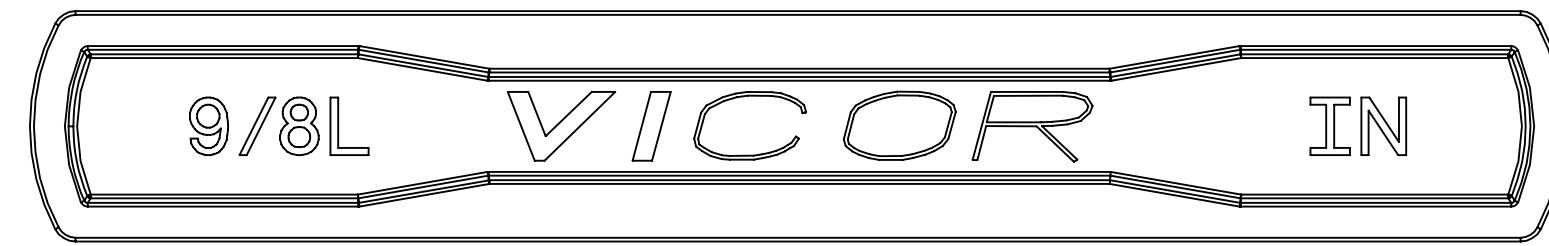

DASH NO.	SOCKET BODY LENGTH	DIM "A"	DIM "B"	INPUT	OUTPUT	KIT#
-01	.100/2.54	.280/7.11	.280/7.11	18378	18388	18364
-02	.135/3.43	.315/8.00	.315/8.00	18379	18389	18365
-03	.160/4.06	.340/8.64	.340/8.64	21539	21543	21510

NOTE:  
 1. MATERIALS: INMATES: PPS RYTON 7  
 SOCKETS: BE-CU #25, Au PLATED.  
 2. FULLY SEAT SOCKET INTO INMATE HEADER.  
 3. ROHS COMPLIANT PER CST-0001 LATEST REVISION.

DRAWN BY: Lap Nguyen DATE: 6/99  
 UNLESS OTHERWISE SPECIFIED DIMENSIONS ARE: INCH / [MM]  
 TOLERANCES ARE: DECIMALS ANGLES  
 XXX [X.X] = +0.01 [0.25] ±1°  
 XXXX [X.XX] = ±0.005 [0.127]  
 THIRD ANGLE PROJECTION  
 DO NOT SCALE DRAWING

SCALE: 4:1

VICOR  
 DWG, VI-900  
 INMATE/SOCKET, BOB

SIZE: D CAGE CODE: 67131 DWG NO: 18480-XX REV: 5  
 SHEET 1 OF 1

