

LOC		DIST		REVISIONS					
ES		00		P	LTN	DESCRIPTION	DATE	DWN	APVD
A1						ADD NEW PART -4, -5, -6	15OCT2012	AY	SZ
A2						UPDATE -4, -5, -6 CONTACT SEQUENCE	23OCT2012	AY	SZ
A3						CORRECT PART -4 PCB LAYOUT	07NOV2012	AY	SZ

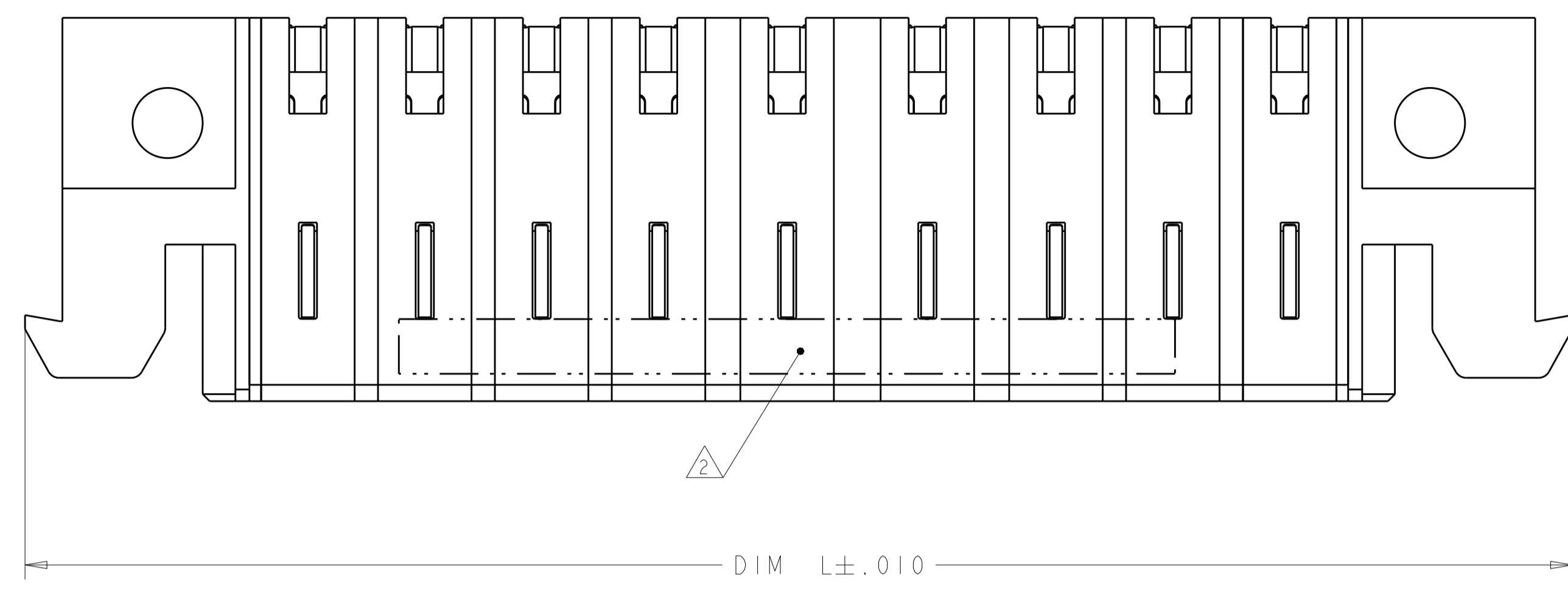

- 1 DIM S IS CENTERLINE SPACING OF POWER MODULES
- 2 "AMP", PART NUMBER, AND DATE CODE TO BE MARKED IN AREA SHOWN PARTS UNDER 2.00 LONG MAY BE MARKED ON BOTH SIDES
- 3 MATERIAL: HOUSING - GLASS FILLED HIGH TEMP THERMO PLASTIC, UV94 V-O  
 SIGNAL CONTACT - HIGH CONDUCTIVITY COPPER ALLOY  
 POWER CONTACT - HIGH CONDUCTIVITY COPPER ALLOY
- 4 CONTACT PLATING: NOBLE METAL PLATING ON CONTACT FUNCTIONAL AREA OF POWER AND SIGNAL CONTACTS
- 5 MECHANICAL CONNECTOR KEEP OUT ZONE
- 6 DATUM AND BASIC DIMENSIONS ESTABLISHED BY CUSTOMER
- 7 PCB - ALL HOLE DIAMETERS ARE FINISHED HOLE SIZES
- 8 PCB - .0453 ±.0010 DRILLED HOLE PLATED WITH .0003 MIN Sn OVER .001-.003 PLATING TO ACHIEVE A .040 HOLE
- 9 VARIABLE DIMENSION SHOW ON VIEW (SHEET 3).
- 10 "P +S + P" TYPE SEE SHEET 2

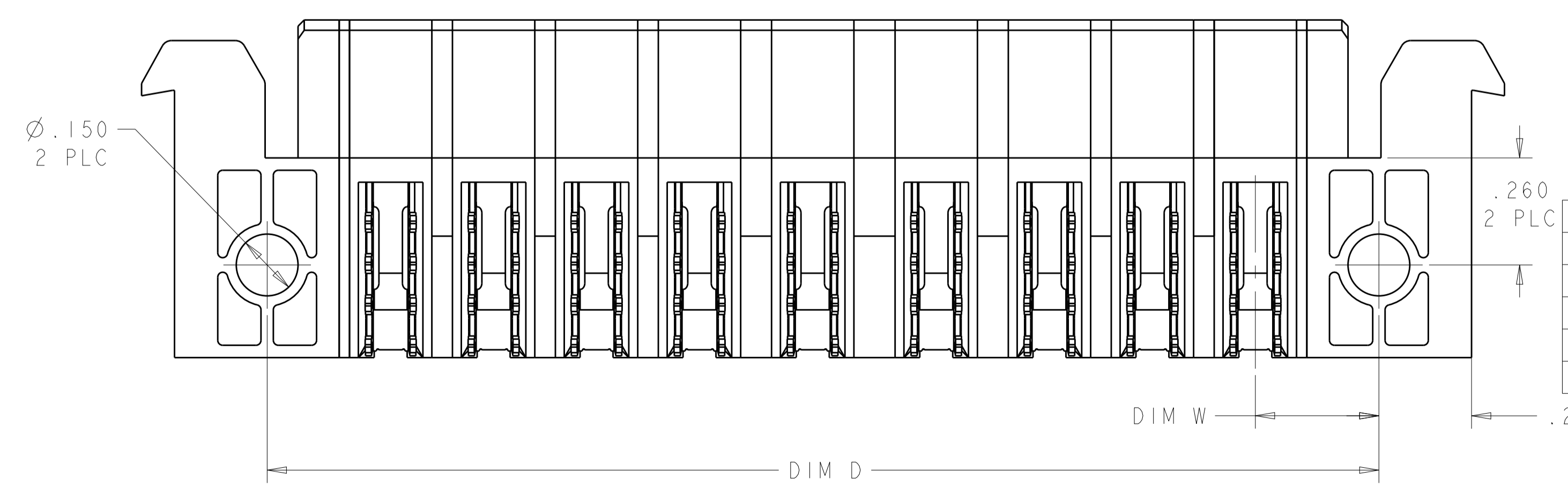
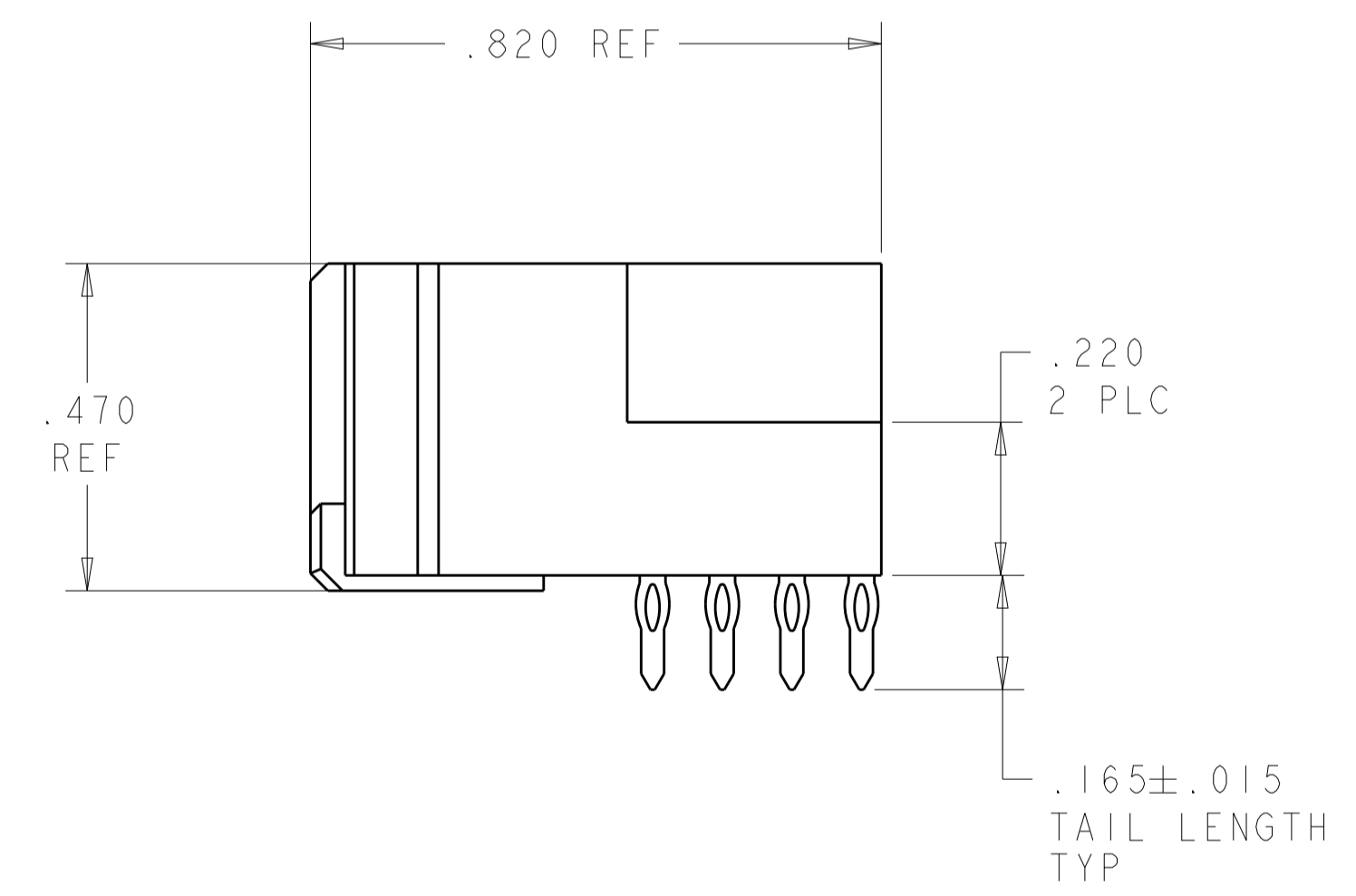
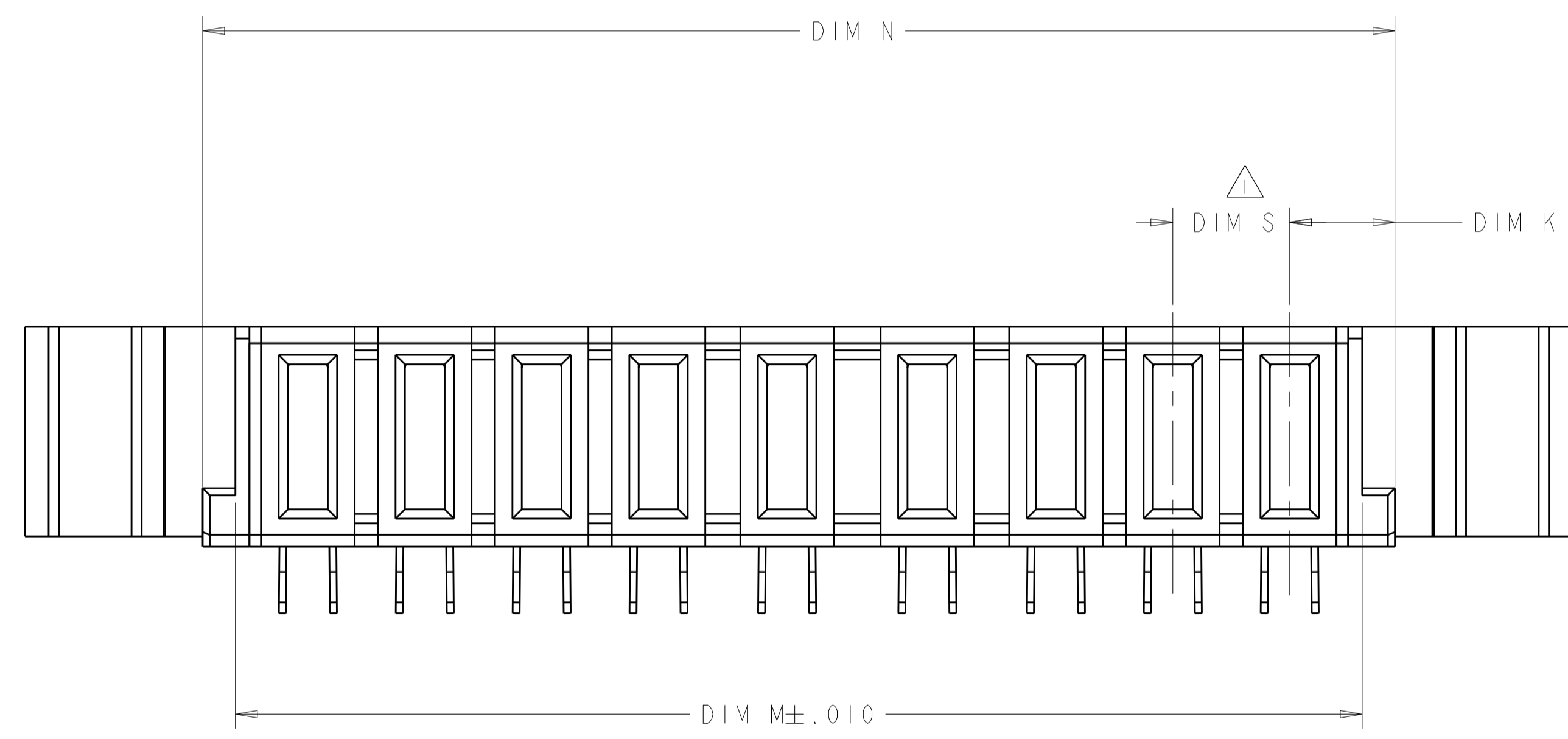

1.175	.675	.200	.200	1.500	1.360	1.650	.275	.200	2.260	2HDP + 16S +2HDP	6450773-6
.775	.475	-	-	.900	.760	1.050	.275	.200	1.660	IP + 8S +IP	6450773-5
.975	.475	-	-	1.100	.960	1.250	.275	.200	1.860	IP + 16S +IP	6450773-4
-	-	-	9	1.300	1.160	1.450	.300	.225	2.060	4P	6450773-2
-	-	-	9	2.550	2.410	2.700	.300	.225	3.310	9P	6450773-1
DIM H	DIM R	DIM T	DIM S	DIM N	DIM M	DIM D	DIM W	DIM K	DIM L	DESCRIPTION	PART NUMBER

THIS DRAWING IS A CONTROLLED DOCUMENT. DWN: GECILY.ZHOU 09OCT2006  
 CHK: S.ZHAO 09OCT2006

**STE** TE Connectivity

NAME: RIGHT ANGLE RECEPTACLE ASSEMBLY PRESS FIT, WITH LATCH RECEIVERS MULTI-BEAM XL

PRODUCT SPEC: 108-1973  
 APPLICATION SPEC: 114-13038

SIZE: A1  
 CAGE CODE: 6450773  
 DRAWING NO: 6450773

SCALE: 4:1 SHEET 1 OF 5 REV: A4

LOC		DIST		REVISIONS			
ES	00	P	LTN	DESCRIPTION	DATE	DWN	APVD
-	-	-	-	SEE SHEET 1	-	-	-

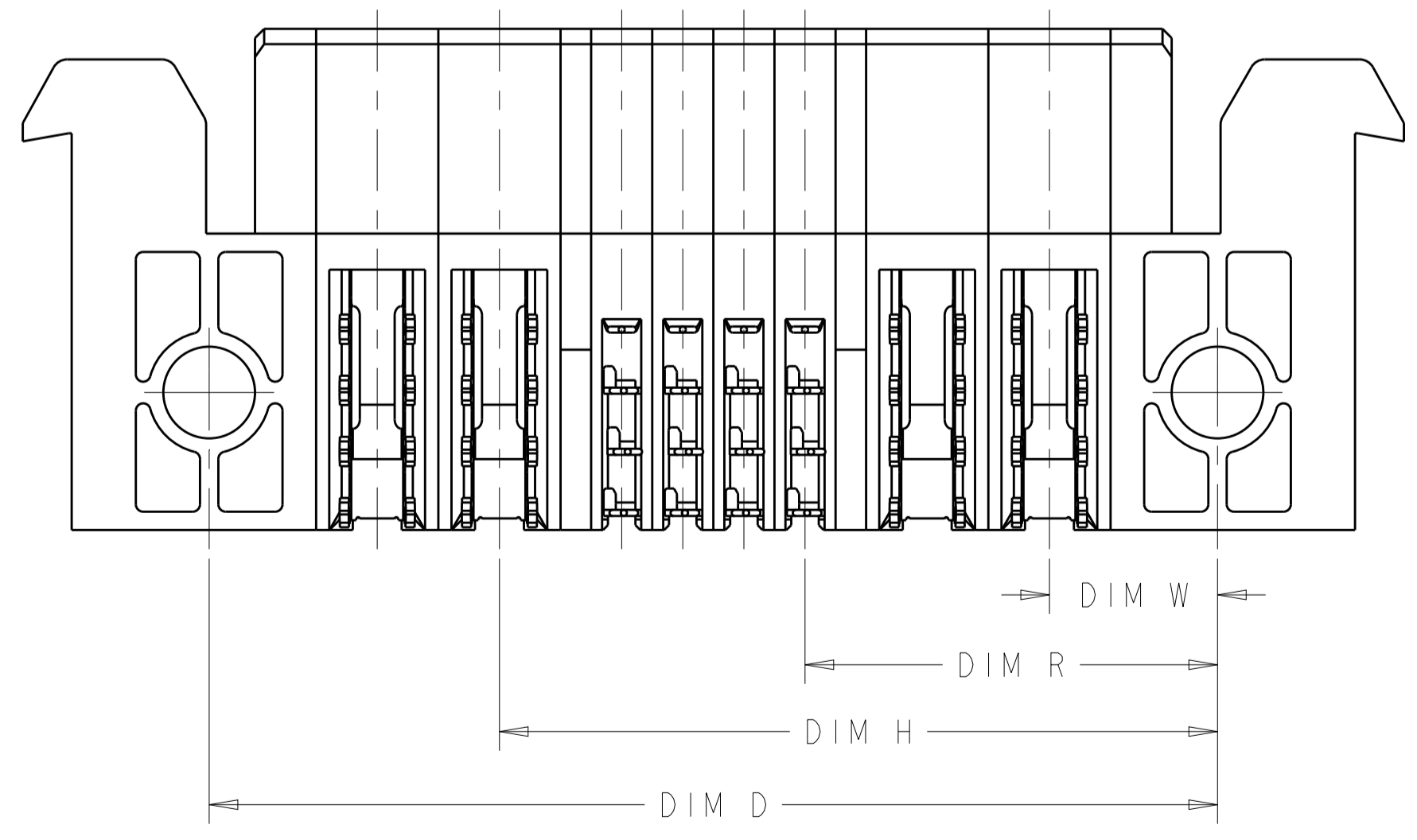
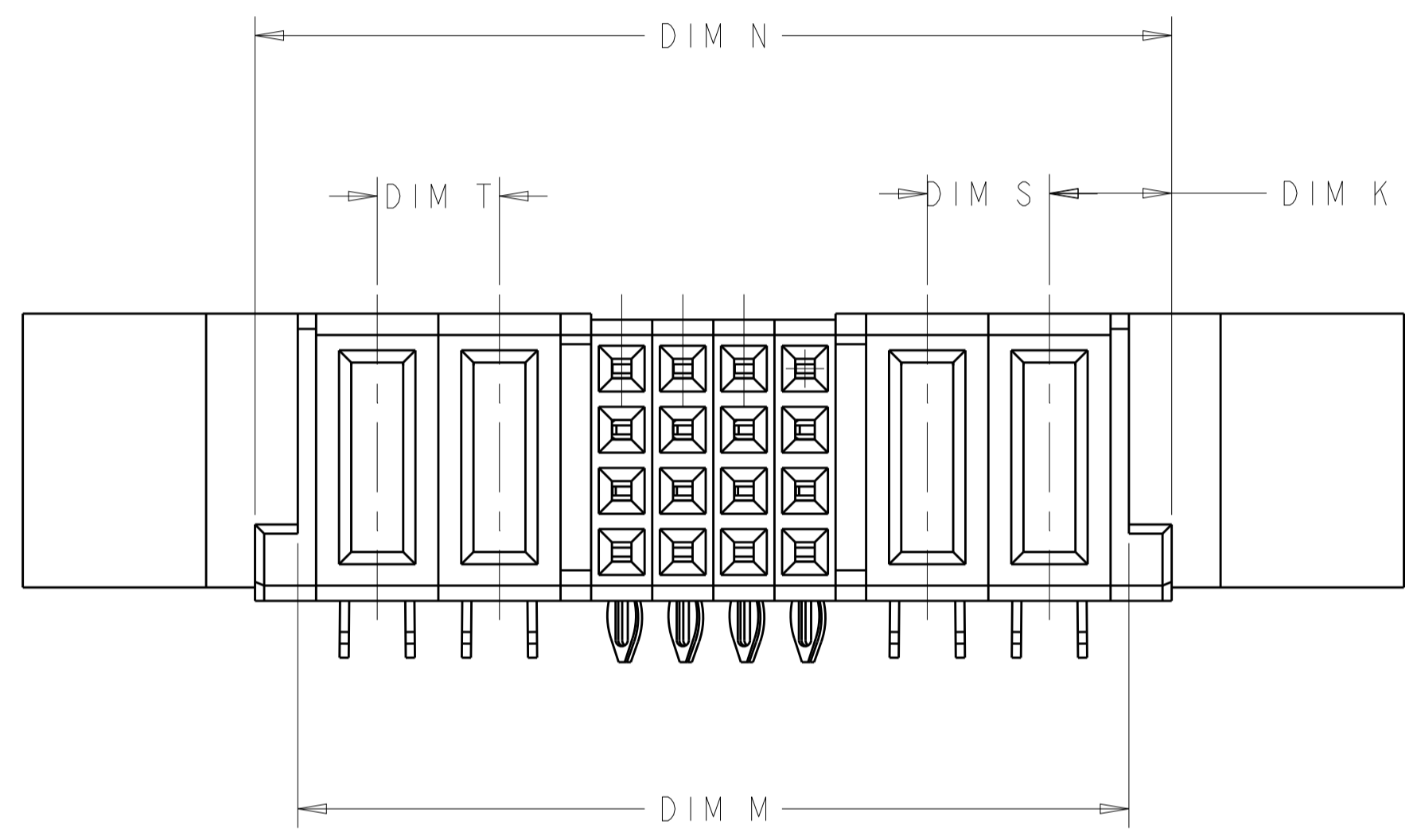
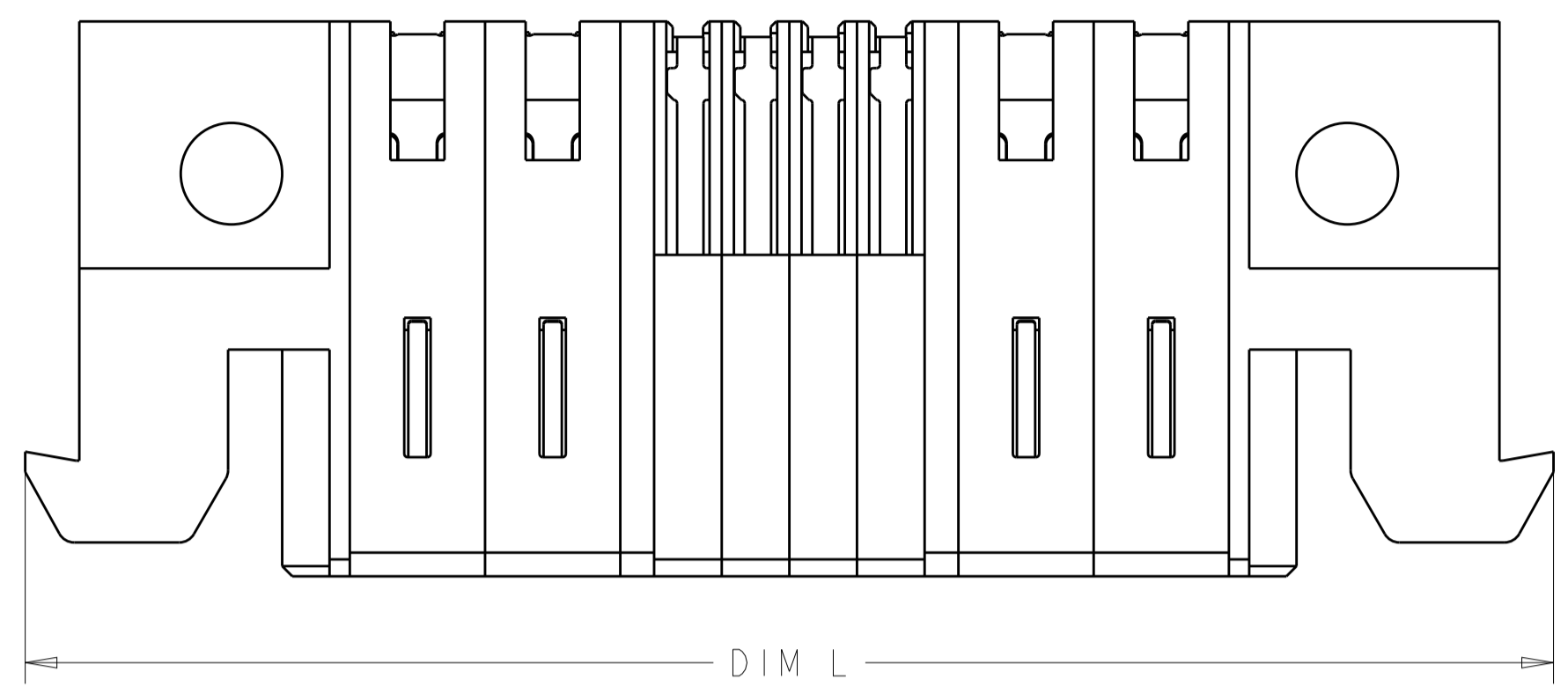

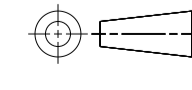
THIS DRAWING IS A CONTROLLED DOCUMENT.		DWN: CECILY.ZHOU 09OCT2006	 TE Connectivity
		CHK: S.ZHAO 09OCT2006	
DIMENSIONS:		APVD: S.YAO	NAME: RIGHT ANGLE RECEPTACLE ASSEMBLY
INCHES		PRODUCT SPEC: 108-1973	PRESS FIT, WITH LATCH RECEIVERS
0 PLC ±.1 1 PLC ±.01 2 PLC ±.01 3 PLC ±.005 4 PLC ±.0020 ANGLES ±.2°		APPLICATION SPEC: 114-13038	MULTI-BEAM XL
 FINISH: -		SIZE: A1	CAGE CODE: C=6450773
MATERIAL: -		WEIGHT: -	RESTRICTED TO: -
CUSTOMER DRAWING		SCALE: 4:1	SHEET 2 OF 5 REV A4

LOC	DIST	REVISIONS			
P	LTN	DESCRIPTION	DATE	DMN	APVD
ES	00	SEE SHEET 1			

PART NUMBER	ROWS	POWER								
		P9	P8	P7	P6	P5	P4	P3	P2	P1
6450773-1	D C B A	RL	RL	RL	RL	RL	RL	RL	RL	RL
9P										

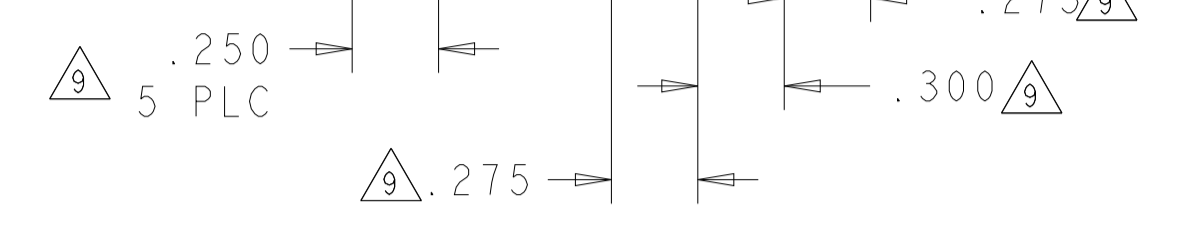

PART NUMBER	ROWS	POWER			
		P4	P3	P2	P1
6450773-2	D C B A	RL	RL	RL	RL
4P					

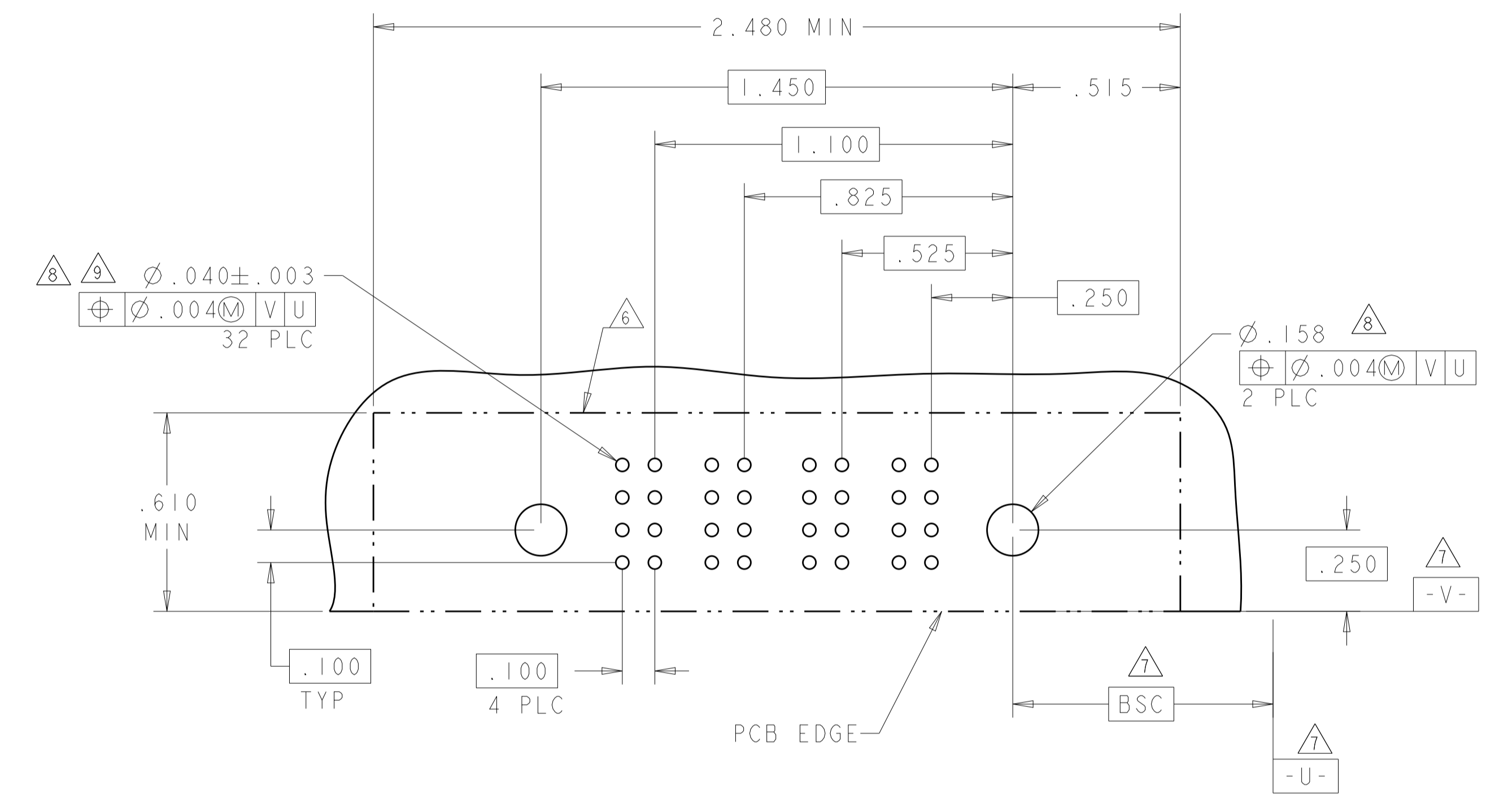
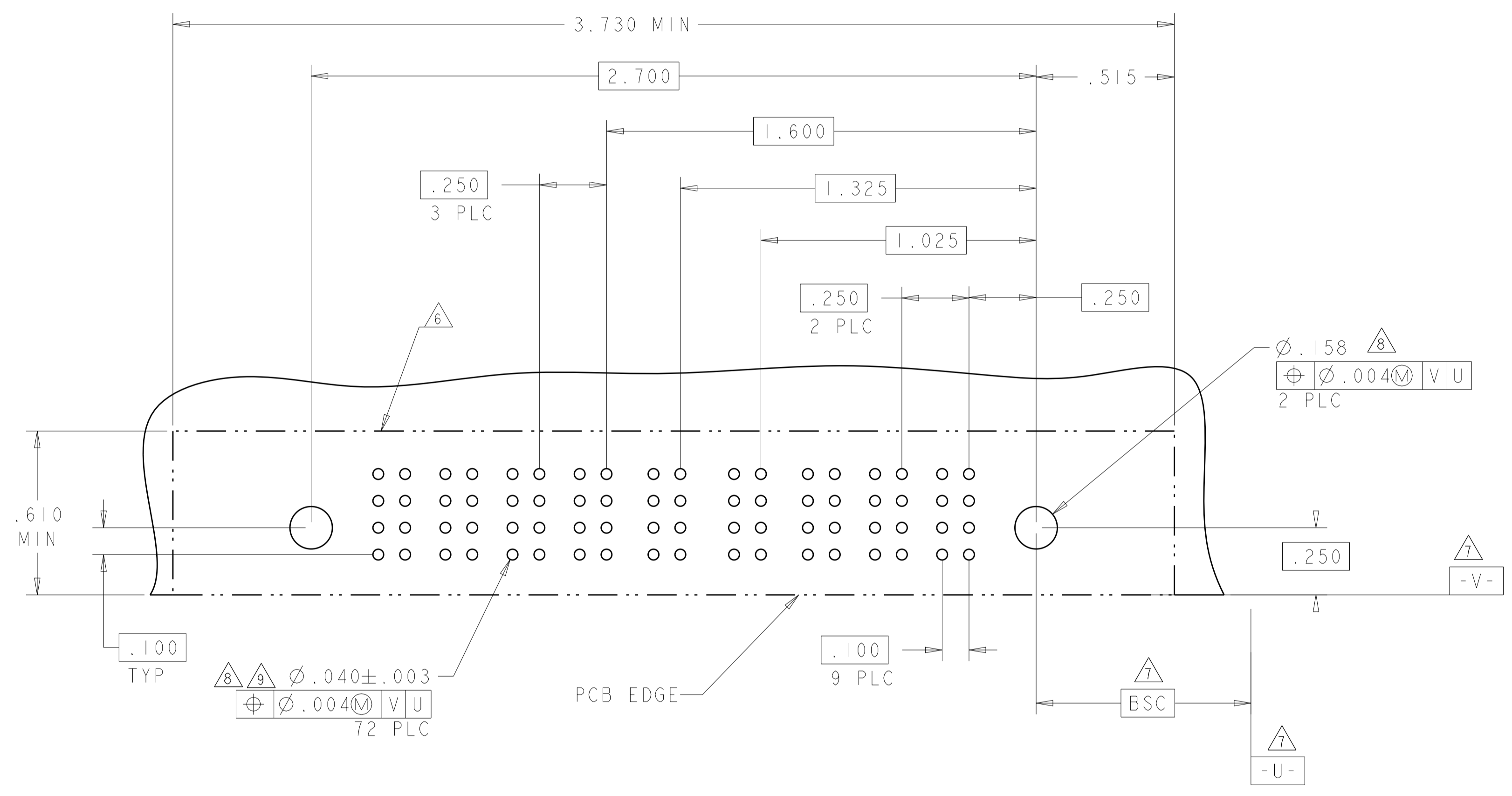
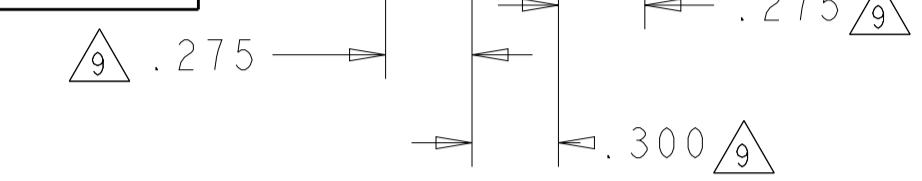

D	SIGNAL CONTACT, PRESS FIT, STD, .119
C	SIGNAL CONTACT, PRESS FIT, STD, .119
B	SIGNAL CONTACT, PRESS FIT, STD, .119
A	SIGNAL CONTACT, PRESS FIT, STD, .119
RP	POWER CONTACT, MFBL, PRESS FIT, STD, .119
RS	POWER CONTACT, PRESS FIT, STD, .119
RL	POWER CONTACT, PRESS FIT, STD, .165
CODE	DESCRIPTION

THIS DRAWING IS A CONTROLLED DOCUMENT.

DIMENSIONS:	TOLERANCES UNLESS OTHERWISE SPECIFIED:	OWN: CECILY.ZHOU 09OCT2006	CHK: S.ZHAO 09OCT2006	NAME: S. YAO
INCHES	0 PLC ±.1 1 PLC ±.1 2 PLC ±.01 3 PLC ±.005 4 PLC ±.0020 ANGLES ±.020	APVD: S. YAO	PRODUCT SPEC: 108-1973	APPLICATION SPEC: 114-13038
MATERIAL:	FINISH:	WEIGHT:	SIZE: A1	CAGE CODE: 6450773
CUSTOMER DRAWING		SCALE: 4:1	SHEET: 3 OF 5	REV: A4

STE TE Connectivity

RIGHT ANGLE RECEPTACLE ASSEMBLY PRESS FIT, WITH LATCH RECEIVERS MULTI-BEAM XL

LOC	DIST	REVISIONS			
P	LTN	DESCRIPTION	DATE	DMN	APVD
ES	00	SEE SHEET 1	-	-	-

(A2)

PART NUMBER	ROWS		POWER		SIGNAL				POWER	
			P2	4	3	2	1	PI		
6450773-4	D	○	RP	D	D	D	D	RS	○	
	C			C	C	C				
	B			B	B	B				
	A			A	A	A				
IP + 16S + IP										

(A2)

PART NUMBER	ROWS		POWER		SIGNAL		POWER	
			P2	2	1	PI		
6450773-5	D	○	RP	D	D	RS	○	
	C			C				
	B			B				
	A			A				
IP + 8S + IP								

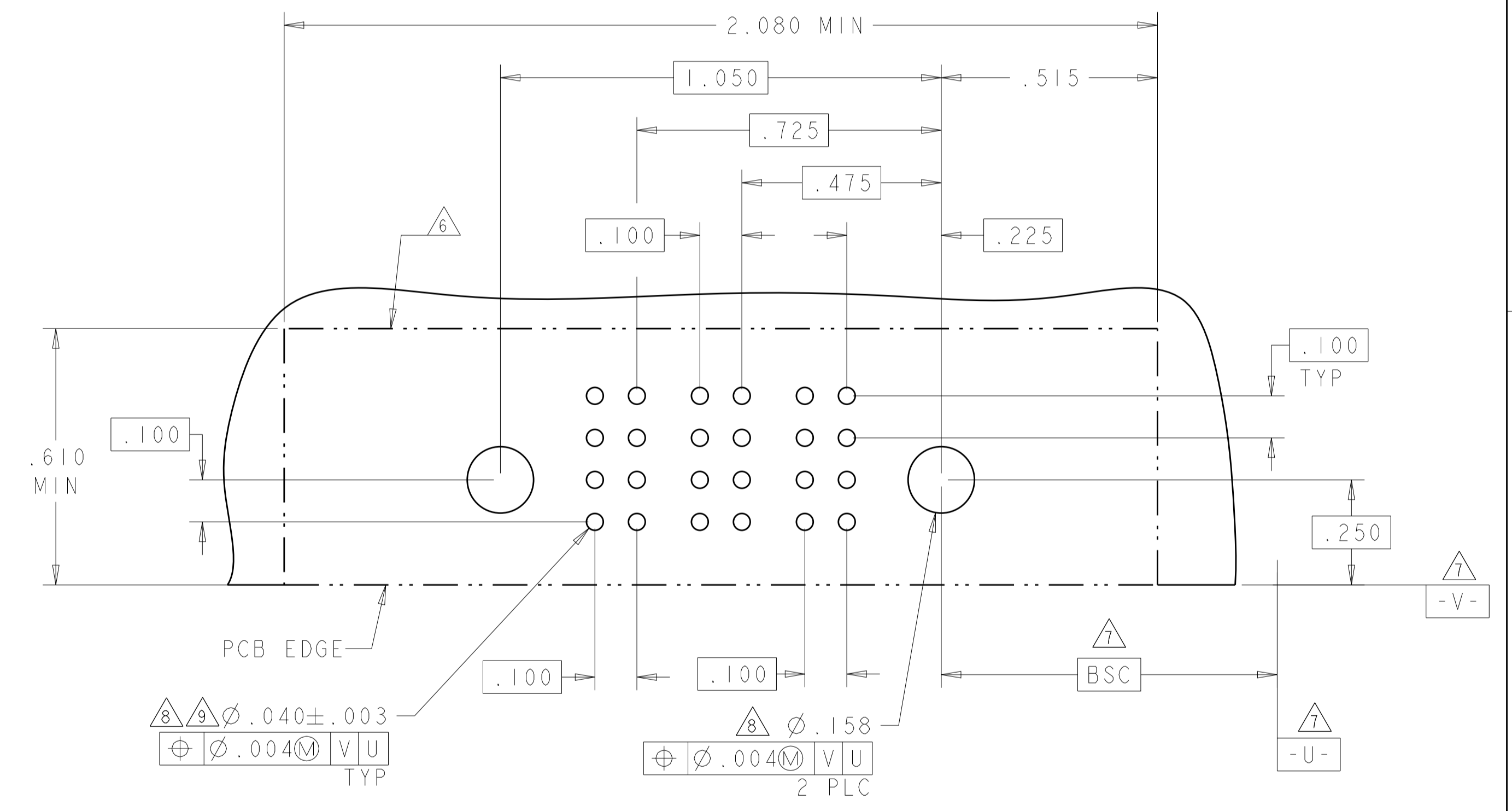
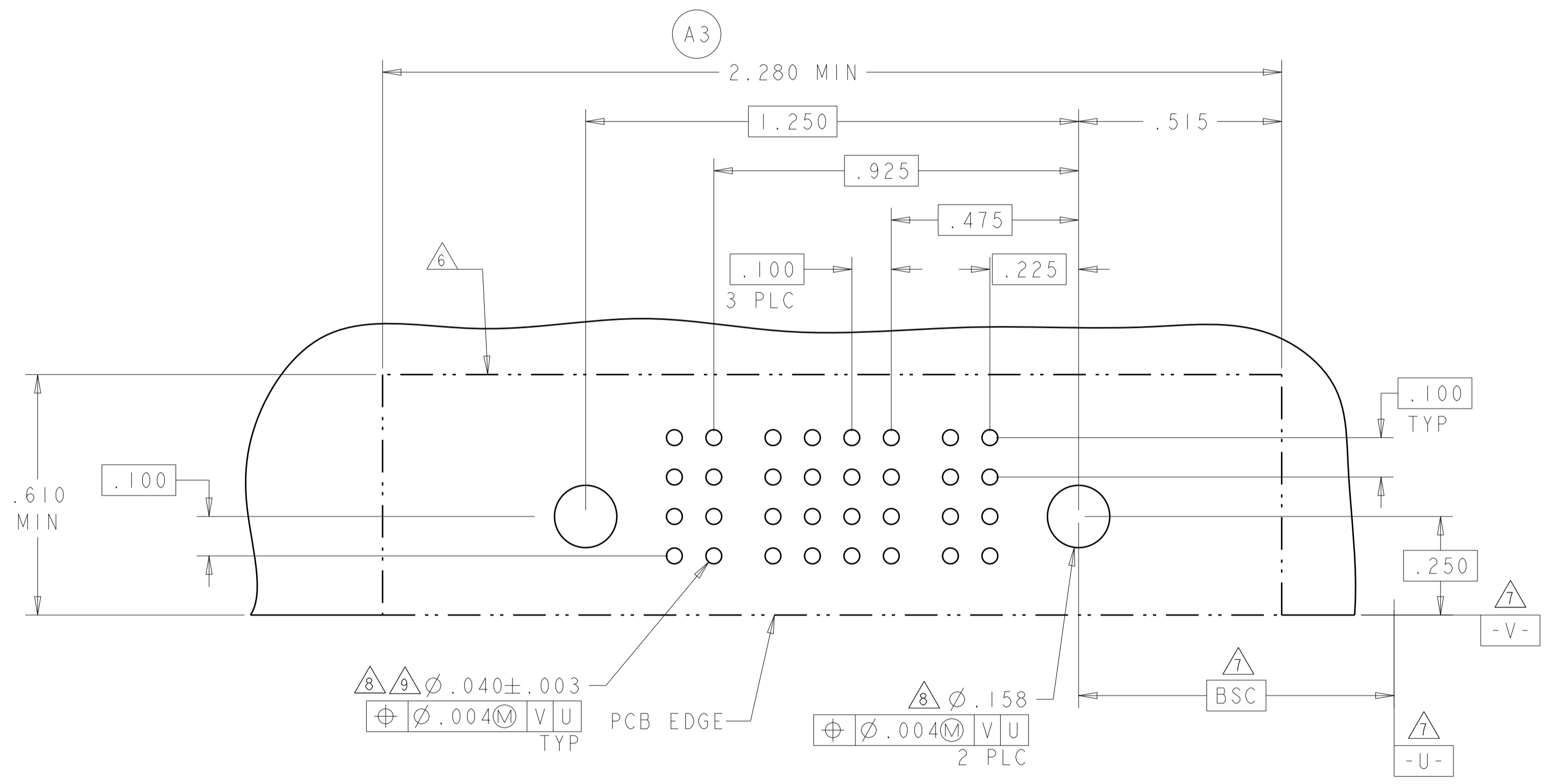

THIS DRAWING IS A CONTROLLED DOCUMENT. DWN: CECILY.ZHOU 09OCT2006  
 CHK: S.ZHAO 09OCT2006

**STE** TE Connectivity

DIMENSIONS: INCHES	TOLERANCES UNLESS OTHERWISE SPECIFIED:	APVD: S. YAO	NAME: S. YAO
0 PLC ±.1	1 PLC ±.01	PRODUCT SPEC: 108-1973	RIGHT ANGLE RECEPTACLE ASSEMBLY PRESS FIT WITH LATCH RECEIVERS MULTI-BEAM XL
2 PLC ±.01	3 PLC ±.005	APPLICATION SPEC: 114-13038	RESTRICTED TO: CUSTOMER DRAWING
4 PLC ±.0020	ANGLES ±.020	WEIGHT: -	SCALE: 4:1 SHEET 4 OF 5 REV: A4

MATERIAL: - FINISH: -

SIZE: A1 CAGE CODE: 6450773 DRAWING NO: 100779

