

AWK-4131A Series

Outdoor industrial IEEE 802.11a/b/g/n wireless AP/bridge/client



- > 2x2 MIMO 802.11a/b/g/n AP/bridge/client
- > Seamless roaming with Client-Based Turbo Roaming
- > Wireless redundancy with AeroLink Protection
- > Rugged industrial design with integrated antenna and power isolation
- > IP68-rated weatherproof housing designed for outdoor applications and -40 to 75°C operating temperatures
- > Avoid wireless congestion with 5 GHz DFS channel support



Introduction

The AWK-4131A IP68 outdoor industrial AP/bridge/client meets the growing need for faster data transmission speeds by supporting 802.11n technology and allowing 2X2 MIMO communication with a net data rate of up to 300 Mbps. The AWK-4131A is compliant with industrial standards and approvals covering operating temperature, power input voltage, surge, ESD, and vibration. The two redundant DC power inputs increase the reliability of the power supply, and the AWK-4131A can be powered via PoE to make deployment easier. The AWK-4131A can operate on either the 2.4 or 5 GHz bands and is backwards-compatible with existing 802.11a/b/g deployments to future-proof your investments in wireless networks.

Advanced 802.11n Industrial Wireless Solution

- 802.11a/b/g/n compliant AP/bridge/client for flexible deployment
- Software optimized for long distance (LoS, 1 km) wireless communication with external high-gain antenna (available on 5 GHz)

- Supports 60 clients connected concurrently
- DFS channel support allows a wider range of 5 GHz channel selection to avoid existing wireless infrastructure and interference

Advanced Wireless Technology for Mission-Critical Applications

- Seamless roaming with Client-based Turbo Roaming for < 150 ms roaming recovery time between APs (Client mode)
- Supports AeroLink Protection for creating a redundant wireless link (< 300 ms recovery time) between AP and clients (Client mode)

Industrial Ruggedness

- Integrated antenna and power isolation designed to provide 500 V insulation protection against external electrical interference
- IP68 rated metal casing for complete ingress protection for any outdoor weather
- -40 to 75°C wide operating temperature provided for smooth wireless communication in harsh environments

Specifications

WLAN Interface

Standards:

- IEEE 802.11a/b/g/n for Wireless LAN
- IEEE 802.11i for Wireless Security
- IEEE 802.3 for 10BaseT
- IEEE 802.3u for 100BaseT(X)
- IEEE 802.3ab for 1000BaseT
- IEEE 802.3af for Power-over-Ethernet
- IEEE 802.1D for Spanning Tree Protocol
- IEEE 802.1w for Rapid STP
- IEEE 802.1Q for VLAN

Spread Spectrum and Modulation (typical):

- DSSS with DBPSK, DQPSK, CCK
- OFDM with BPSK, QPSK, 16QAM, 64QAM
- 802.11b: CCK @ 11/5.5 Mbps, DQPSK @ 2 Mbps, DBPSK @ 1 Mbps
- 802.11a/g: 64QAM @ 54/48 Mbps, 16QAM @ 36/24 Mbps, QPSK @ 18/12 Mbps, BPSK @ 9/6 Mbps
- 802.11n: 64QAM @ 300 Mbps to BPSK @ 6.5 Mbps (multiple rates supported)

Operating Channels (central frequency):

US:

- 2.412 to 2.462 GHz (11 channels)
- 5.180 to 5.240 GHz (4 channels)
- 5.260 to 5.320 GHz (4 channels)*
- 5.500 to 5.700 GHz (8 channels, excluding 5.600 to 5.640 GHz)*
- 5.745 to 5.825 GHz (5 channels)

EU:

- 2.412 to 2.472 GHz (13 channels)
- 5.180 to 5.240 GHz (4 channels)*
- 5.260 to 5.320 GHz (4 channels)
- 5.500 to 5.700 GHz (11 channels)*

JP:

- 2.412 to 2.484 GHz (14 channels)
- 5.180 to 5.240 GHz (4 channels)
- 5.260 to 5.320 GHz (4 channels)*
- 5.500 to 5.700 GHz (11 channels)*

*DFS (Dynamic Frequency Selection) channel support: In AP mode, when a radar signal is detected, the device will automatically switch to another channel. However according to regulations, after switching channels, a 60-second availability check period is required before starting the service.

Security:

- SSID broadcast enable/disable
- Firewall for MAC/IP/Protocol/Port-based filtering
- 64-bit and 128-bit WEP encryption, WPA/WPA2-Personal and Enterprise (IEEE 802.1X/RADIUS, TKIP, and AES)

Transmission Rates:

802.11b: 1, 2, 5.5, 11 Mbps
 802.11a/g: 6, 9, 12, 18, 24, 36, 48, 54 Mbps
 802.11n: 6.5 to 300 Mbps (multiple rates supported)

TX Transmit Power:

802.11b:
 Typ. 26±1.5 dBm @ 1 Mbps, Typ. 26±1.5 dBm @ 2 Mbps
 Typ. 26±1.5 dBm @ 5.5 Mbps, Typ. 25±1.5 dBm @ 11 Mbps
 802.11g:
 Typ. 23±1.5 dBm @ 6 to 24 Mbps, Typ. 22±1.5 dBm @ 36 Mbps
 Typ. 20±1.5 dBm @ 48 Mbps, Typ. 19±1.5 dBm @ 54 Mbps
 802.11n (2.4 GHz):
 Typ. 23±1.5 dBm @ MCS0/8 20 MHz,
 Typ. 18±1.5 dBm @ MCS7/15 20 MHz,
 Typ. 23±1.5 dBm @ MCS0/8 40 MHz,
 Typ. 17±1.5 dBm @ MCS7/15 40 MHz
 802.11a:
 Typ. 23±1.5 dBm @ 6 to 24 Mbps, Typ. 21±1.5 dBm @ 36 Mbps
 Typ. 20±1.5 dBm @ 48 Mbps, Typ. 18±1.5 dBm @ 54 Mbps
 802.11n (5 GHz):
 Typ. 23±1.5 dBm @ MCS0/8 20 MHz,
 Typ. 18±1.5 dBm @ MCS7/15 20 MHz,
 Typ. 23±1.5 dBm @ MCS0/8 40 MHz,
 Typ. 18±1.5 dBm @ MCS7/15 40 MHz

Note: Based on regional regulations, the maximum transmission power allowed on the UNII bands is restricted in the firmware, as per the following list:

	US	EU	JP
2.4 GHz	20 dBm	20 dBm	20 dBm
5 GHz (UNII-1)	17 dBm	20 dBm	20 dBm
5 GHz (UNII-2)	20 dBm	20 dBm	20 dBm
5 GHz (UNII-2e)	20 dBm	20 dBm	20 dBm
5 GHz (UNII-3)	20 dBm	20 dBm	20 dBm

RX Receive Sensitivity:

802.11b:
 -93 dBm @ 1 Mbps, -93 dBm @ 2 Mbps
 -93 dBm @ 5.5 Mbps, -88 dBm @ 11 Mbps
 802.11g:
 -88 dBm @ 6 Mbps, -86 dBm @ 9 Mbps
 -85 dBm @ 12 Mbps, -85 dBm @ 18 Mbps
 -85 dBm @ 24 Mbps, -82 dBm @ 36 Mbps
 -78 dBm @ 48 Mbps, -74 dBm @ 54 Mbps
 802.11n (2.4 GHz):
 -70 dBm @ MCS7 20 MHz, -69 dBm @ MCS15 20 MHz
 -67 dBm @ MCS7 40 MHz, -67 dBm @ MCS15 40 MHz
 802.11a:
 -90 dBm @ 6 Mbps, -88 dBm @ 9 Mbps
 -88 dBm @ 12 Mbps, -85 dBm @ 18 Mbps
 -81 dBm @ 24 Mbps, -78 dBm @ 36 Mbps
 -74 dBm @ 48 Mbps, -72 dBm @ 54 Mbps
 802.11n (5 GHz):
 -69 dBm @ MCS7 20 MHz, -71 dBm @ MCS15 20 MHz
 -63 dBm @ MCS7 40 MHz, -68 dBm @ MCS15 40 MHz

Protocol Support

General Protocols: Proxy ARP, DNS, HTTP, HTTPS, IP, ICMP, SNMP, TCP, UDP, RADIUS, SNMP, DHCP, VLAN, STP/RSTP

Interface

Default Antennas: 2 dual-band omni-directional antennas, 5 dBi at 2.4 GHz, 2 dBi at 5 GHz, N-type (male)

Connector for External Antennas: N-Type (female), 500 V insulation

LAN Ports: 1, RJ45, 10/100/1000BaseT(X) auto negotiation speed, F/H duplex mode, and auto MDI/MDI-X connection

Console Port: RS-232 (waterproof RJ45-type)

Reset: Present

LED Indicators: PWR, FAULT, STATE, WLAN, LAN

Alarm Contact (digital output): 8-pin M12 A-coded connector (female), 1 relay output with current carrying capacity of 1 A @ 24 VDC

Digital Inputs: 8-pin M12 A-coded connector (female), 2 electrically isolated inputs

- +13 to +30 V for state “1”
- +3 to -30 V for state “0”
- Max. input current: 8 mA

Management

Device Management: Wireless Search Utility, MXconfig, SNMP

Network Monitoring: MXview

Physical Characteristics

Housing: Metal, IP68 protection

Weight: 1400 g (3.09 lb)

Dimensions: 224 x 147.7 x 66.5 mm (8.82 x 5.82 x 2.62 in)

Installation: Wall mounting (standard), DIN-rail mounting (optional), pole mounting (optional)

Environmental Limits

Operating Temperature: -40 to 75°C (-40 to 167°F)

Storage Temperature: -40 to 85°C (-40 to 185°F)

Ambient Relative Humidity: 5% to 95% (non-condensing)

Power Requirements

Input Voltage: 12 to 48 VDC, redundant dual DC power inputs or 48 VDC Power-over-Ethernet (IEEE 802.3af compliant)

Input Current: 0.64 A @ 12 VDC; 0.16 A @ 48 VDC

Connector: 5-pin M12 A-coded connector (male), 500 V insulation

Power Consumption: 7.68 W

Reverse Polarity Protection: Present

Standards and Certifications

Safety: UL 60950-1, EN 60950-1

EMC: EN 61000-6-2/6-4

EMI: CISPR 22, FCC Part 15B Class B

EMS:

IEC 61000-4-2 ESD: Contact: 8 kV; Air: 15 kV

IEC 61000-4-3 RS: 80 MHz to 1 GHz: 10 V/m

IEC 61000-4-4 EFT: Power: 2 kV; Signal: 1 kV

IEC 61000-4-5 Surge: Power: 2 kV; Signal: 2 kV

IEC 61000-4-6 CS: 10 V

IEC 61000-4-8

Radio: EN 301 489-1/17, EN 300 328, EN 301 893, TELEC, FCC ID

SLE-WAPN008

Note: Please check Moxa's website for the most up-to-date certification status.

MTBF (mean time between failures)

Time: 440,764 hrs

Standard: Telcordia SR332

Warranty

Warranty Period: 5 years

Details: See www.moxa.com/warranty

Dimensions

Unit: mm (inch)

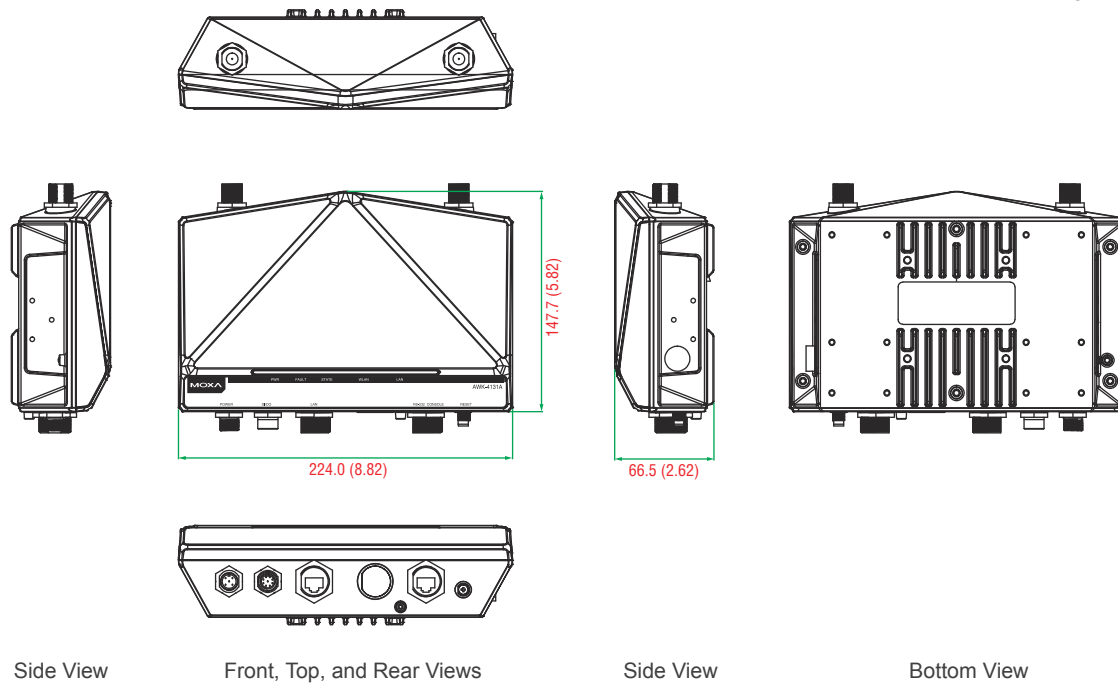

Side View

Front, Top, and Rear Views

Side View

Bottom View

Ordering Information

Available Models

AWK-4131A-US-T: IEEE 802.11a/b/g/n IP68 wireless AP/bridge/client, US band, -40 to 75°C operating temperature

AWK-4131A-EU-T: IEEE 802.11a/b/g/n IP68 wireless AP/bridge/client, EU band, -40 to 75°C operating temperature

AWK-4131A-JP-T: IEEE 802.11a/b/g/n IP68 wireless AP/bridge/client, JP band, -40 to 75°C operating temperature

Note: Please visit Moxa's website for a complete list of optional wireless accessories and antennas available for Moxa's wireless products.

Package Checklist

- AWK-4131A wireless AP/bridge/client
- 2 2.4/5 GHz antennas: ANT-WDB-ANM-0502
- Wall-mounting kit (includes 2 supports)
- Field-installable power plug
- Field-installable RJ45 plug
- Metal cap to cover RJ45 connector
- Metal cap to cover M12-female connector
- Transparent plastic sticks for field-installable plugs
- Quick installation guide (printed)
- Warranty card