



STEVAl-IHP001V2

SmartPlug demonstration board
based on the STM32, SN260 (ZigBee® transceiver) and STPM01

Data brief

Features

- Energy consumption monitoring
- Time-band configuration
- Network/standalone modes
- ZigBee® well suited for home automation application
- Ground fault detection (in the "safety" version)
- Dimming (in the "dimming" version)
- RoHS compliant

Description

The STEVAL-IHP001V2 is a SmartPlug board based on an STM32F10x microcontroller, an SPZB260 ZigBee® module, and an STPM01 energy metering IC.

It implements a ZigBee® metering node which allows the final user to monitor and manage energy consumption.

The board has been developed to provide a guideline to build a home/building automation subsystem for energy management. In a typical home system implementation, the board is plugged into an electrical wall socket and supplies a home appliance or other generic electrical load.

The current, power, energy and other information related to the electrical load connected to the SmartPlug board can be displayed locally on an LCD screen, or send to a ZigBee® data concentrator through the home/building ZigBee® network.

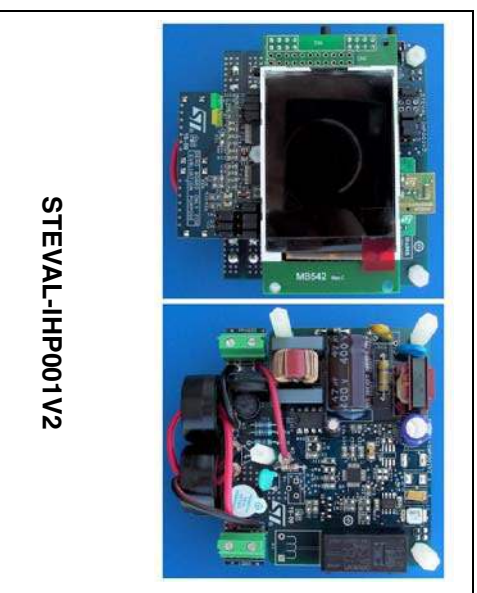

1 Schematics diagram

Figure 1. AC load driver page

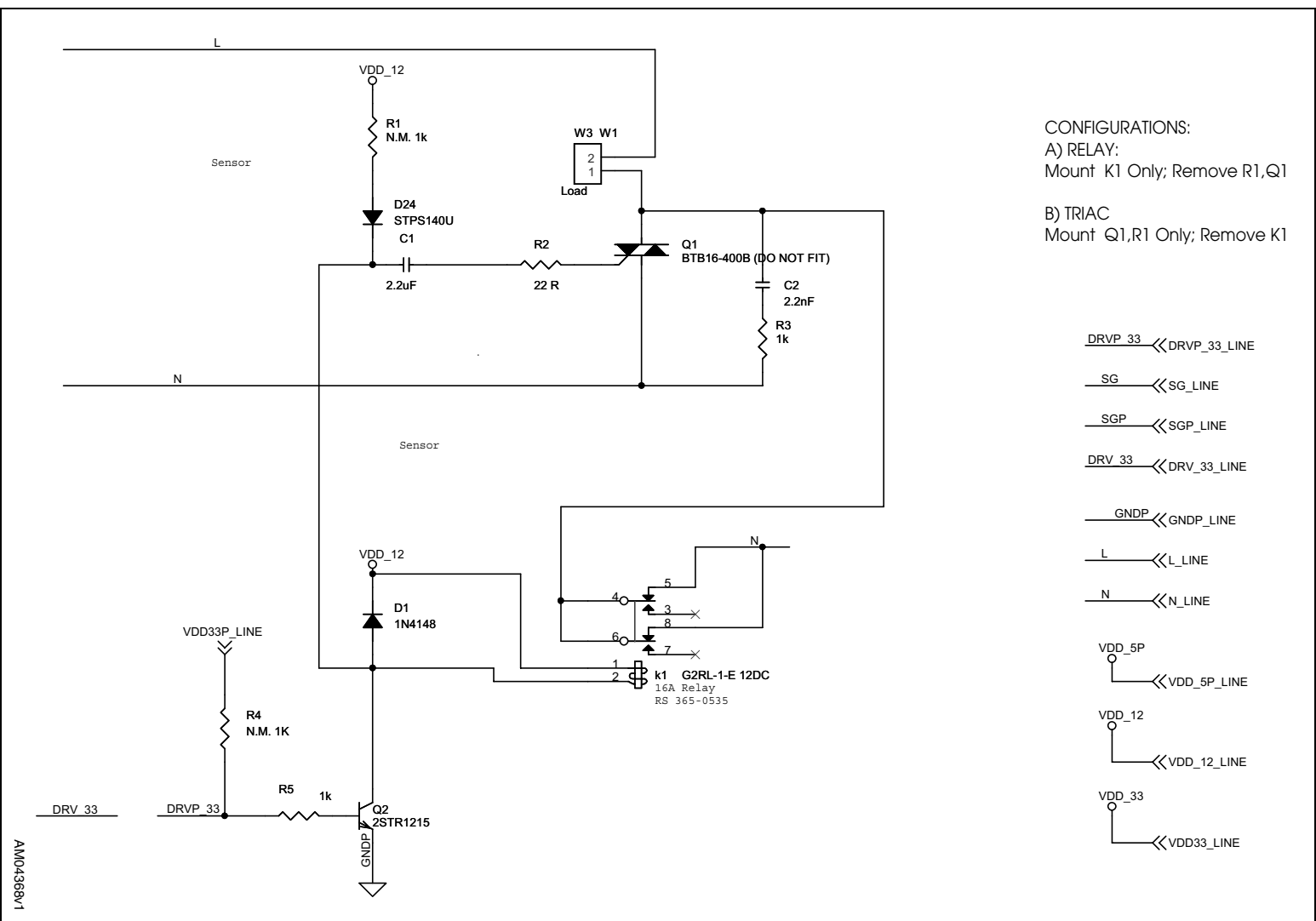
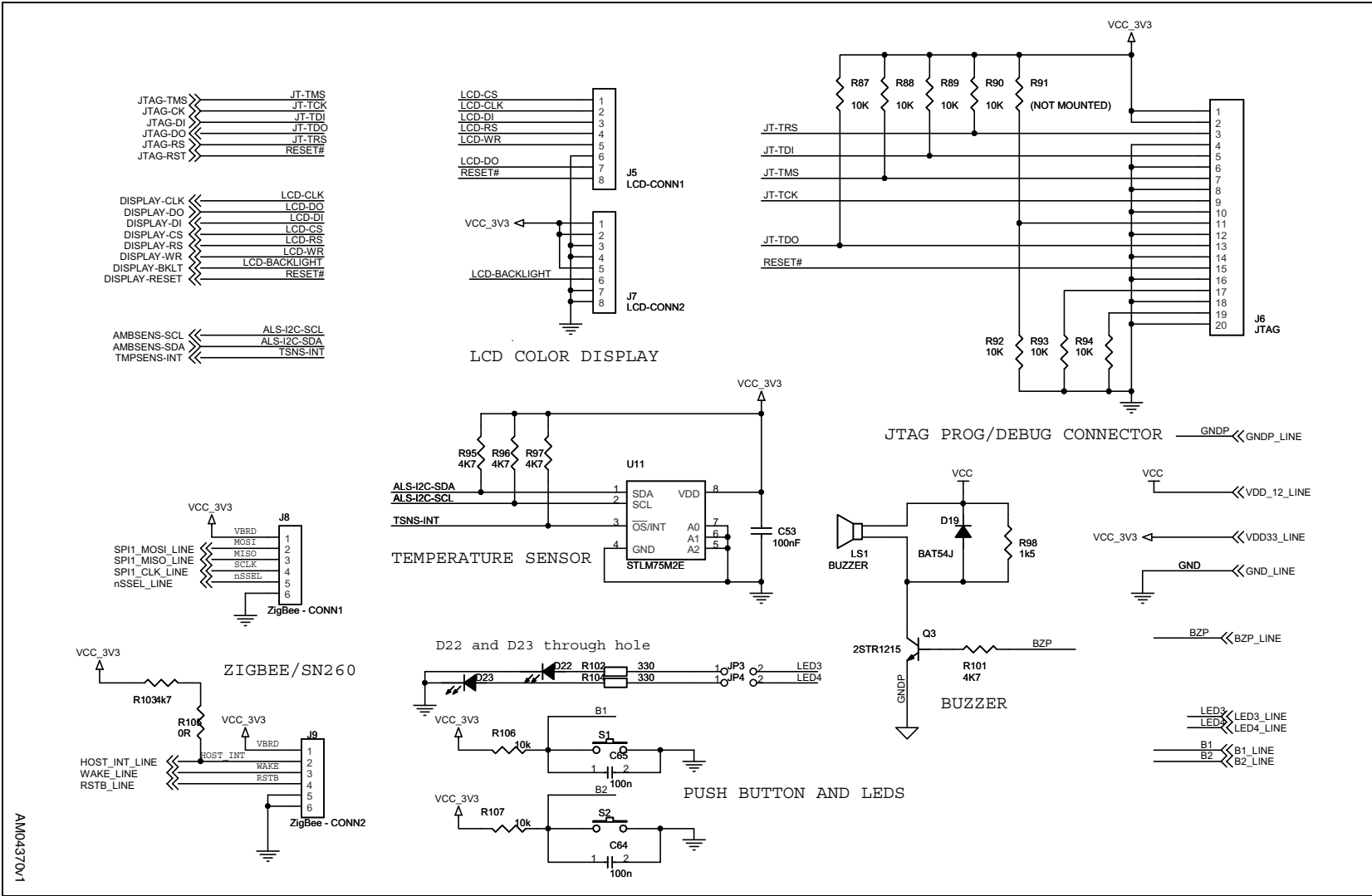
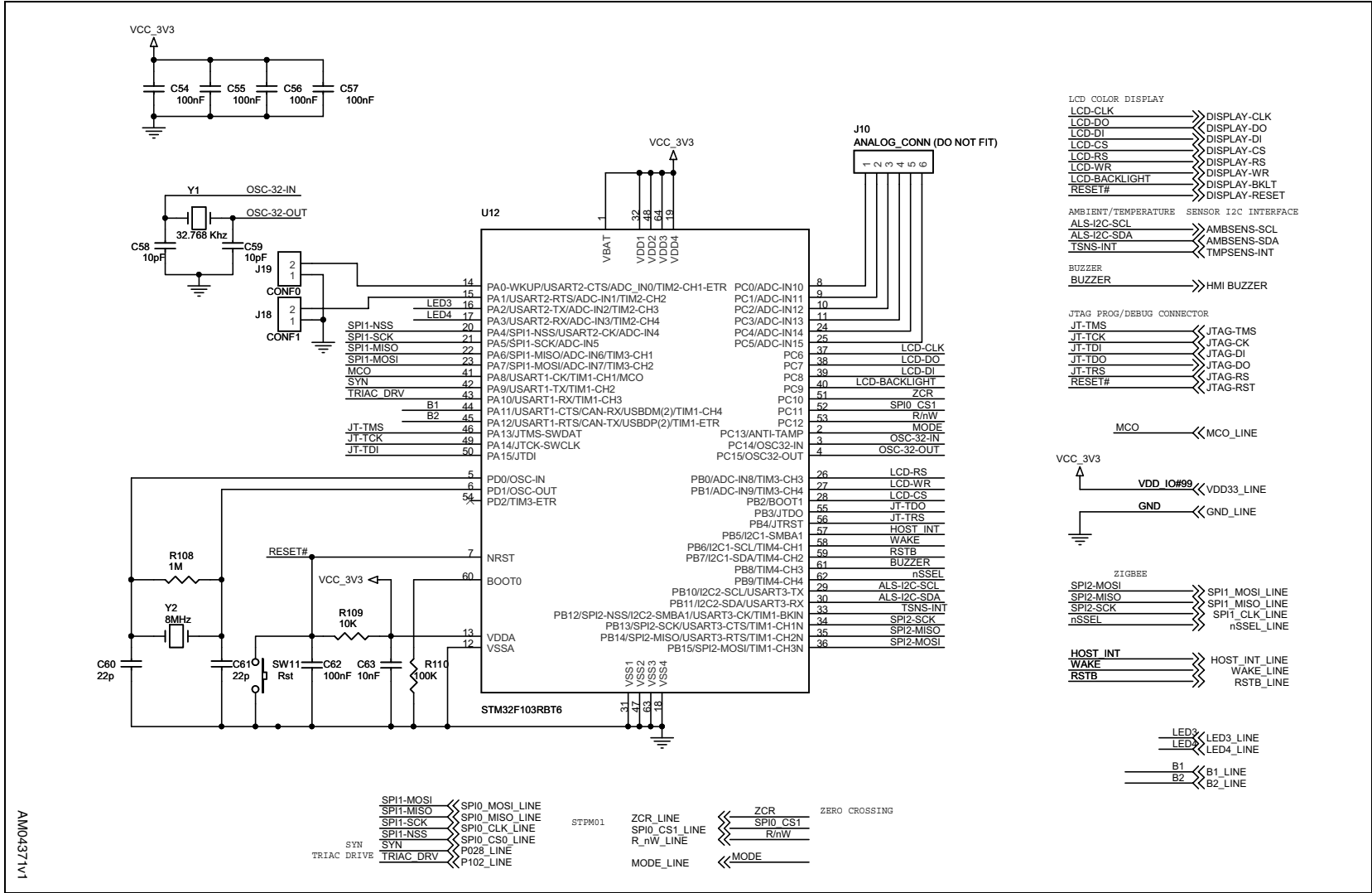

Figure 3. Temperature sensor and connectors





AM04371v1

Figure 4. Microcontroller

Figure 5. Energy meter IC

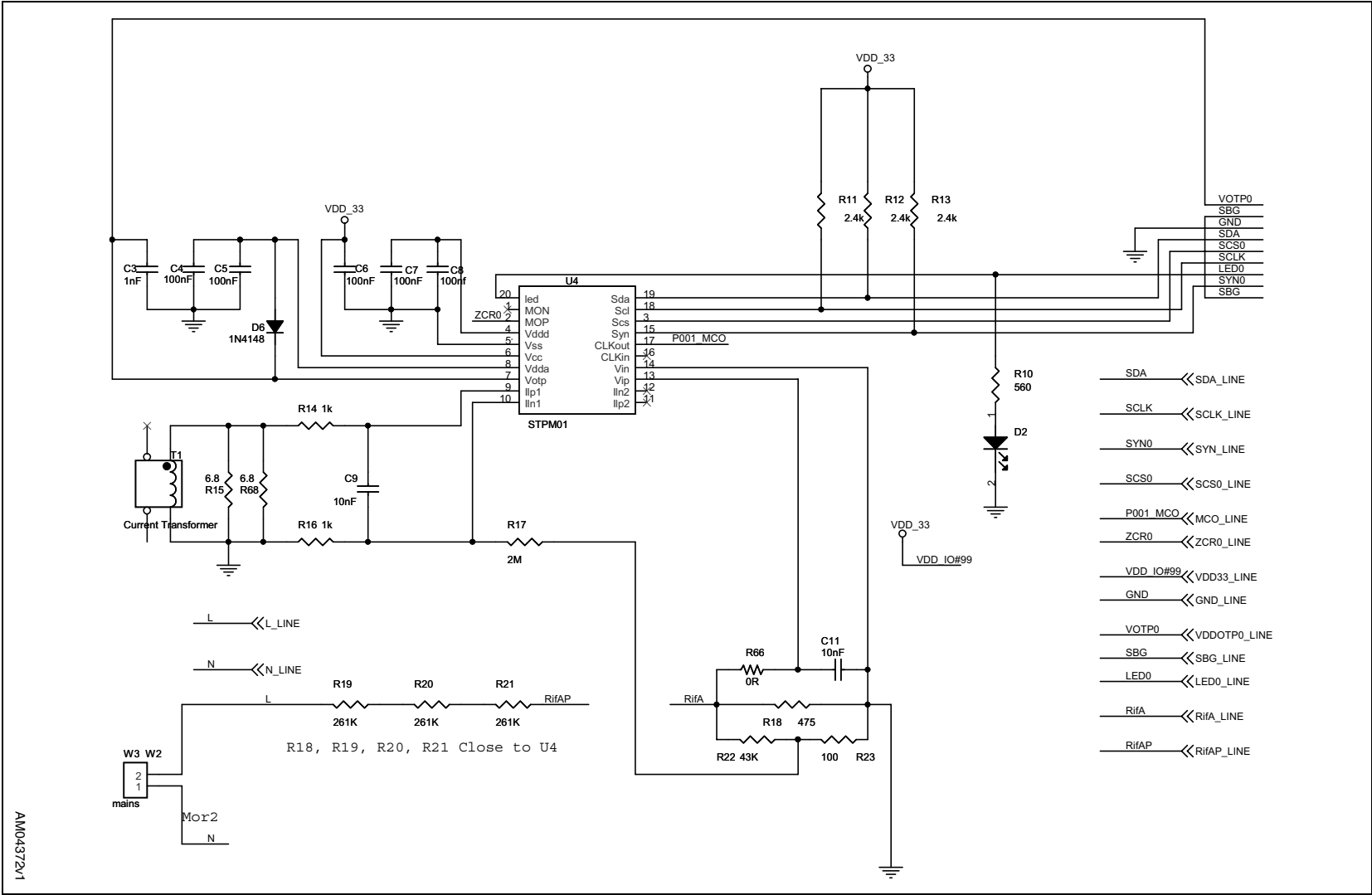

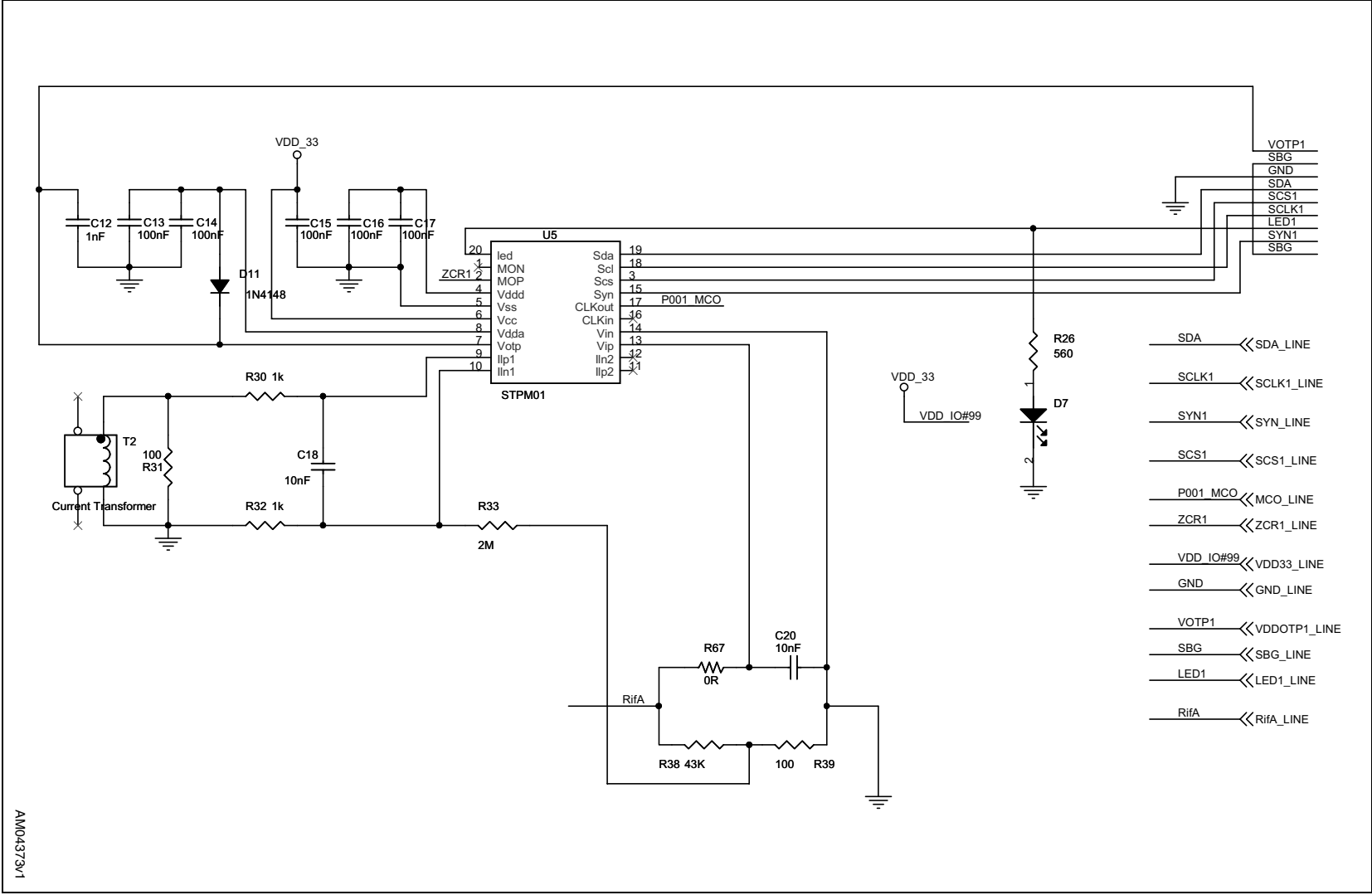

AM04373v1

Figure 6. Differential current meter

Figure 7. AC/DC converter

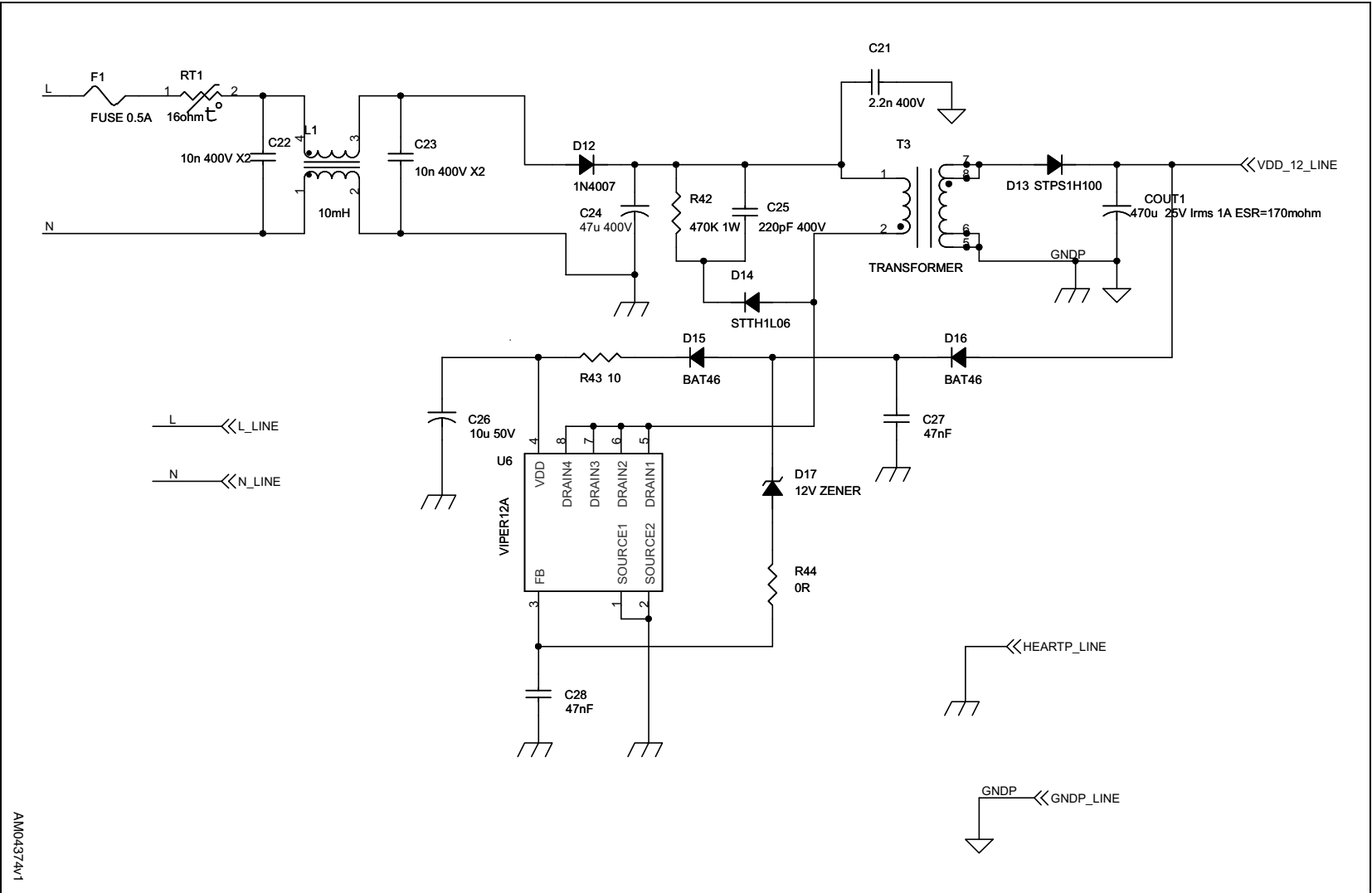

AM04374v1



Figure 8. DC/DC converter

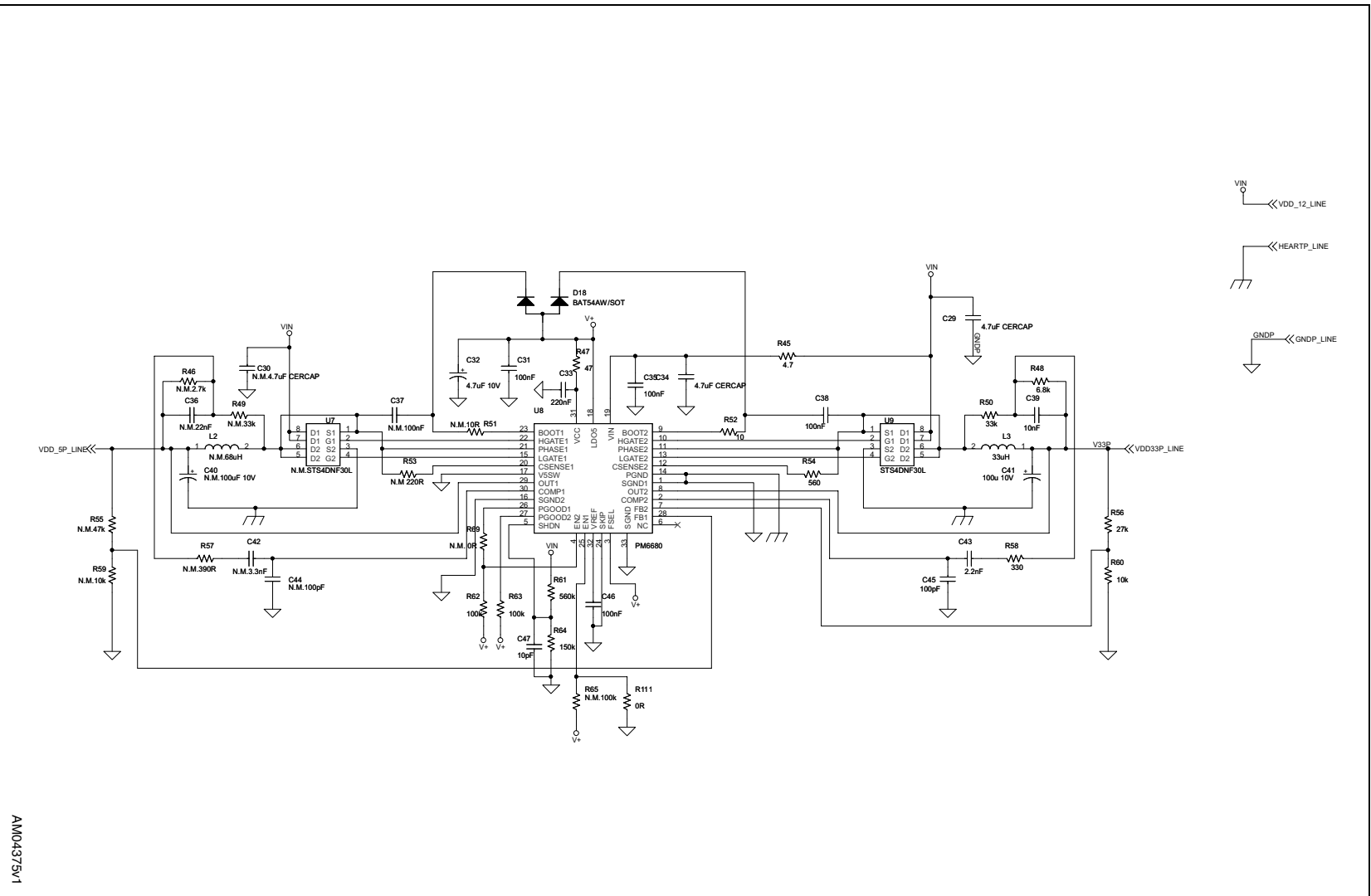

2 Revision history

Table 1. Document revision history

Date	Revision	Changes
01-Jul-2009	1	Initial release.

Please Read Carefully:

Information in this document is provided solely in connection with ST products. STMicroelectronics NV and its subsidiaries ("ST") reserve the right to make changes, corrections, modifications or improvements, to this document, and the products and services described herein at any time, without notice.

All ST products are sold pursuant to ST's terms and conditions of sale.

Purchasers are solely responsible for the choice, selection and use of the ST products and services described herein, and ST assumes no liability whatsoever relating to the choice, selection or use of the ST products and services described herein.

No license, express or implied, by estoppel or otherwise, to any intellectual property rights is granted under this document. If any part of this document refers to any third party products or services it shall not be deemed a license grant by ST for the use of such third party products or services, or any intellectual property contained therein or considered as a warranty covering the use in any manner whatsoever of such third party products or services or any intellectual property contained therein.

UNLESS OTHERWISE SET FORTH IN ST'S TERMS AND CONDITIONS OF SALE ST DISCLAIMS ANY EXPRESS OR IMPLIED WARRANTY WITH RESPECT TO THE USE AND/OR SALE OF ST PRODUCTS INCLUDING WITHOUT LIMITATION IMPLIED WARRANTIES OF MERCHANTABILITY, FITNESS FOR A PARTICULAR PURPOSE (AND THEIR EQUIVALENTS UNDER THE LAWS OF ANY JURISDICTION), OR INFRINGEMENT OF ANY PATENT, COPYRIGHT OR OTHER INTELLECTUAL PROPERTY RIGHT.

UNLESS EXPRESSLY APPROVED IN WRITING BY AN AUTHORIZED ST REPRESENTATIVE, ST PRODUCTS ARE NOT RECOMMENDED, AUTHORIZED OR WARRANTED FOR USE IN MILITARY, AIR CRAFT, SPACE, LIFE SAVING, OR LIFE SUSTAINING APPLICATIONS, NOR IN PRODUCTS OR SYSTEMS WHERE FAILURE OR MALFUNCTION MAY RESULT IN PERSONAL INJURY, DEATH, OR SEVERE PROPERTY OR ENVIRONMENTAL DAMAGE. ST PRODUCTS WHICH ARE NOT SPECIFIED AS "AUTOMOTIVE GRADE" MAY ONLY BE USED IN AUTOMOTIVE APPLICATIONS AT USER'S OWN RISK.

Resale of ST products with provisions different from the statements and/or technical features set forth in this document shall immediately void any warranty granted by ST for the ST product or service described herein and shall not create or extend in any manner whatsoever, any liability of ST.

ST and the ST logo are trademarks or registered trademarks of ST in various countries.

Information in this document supersedes and replaces all information previously supplied.

The ST logo is a registered trademark of STMicroelectronics. All other names are the property of their respective owners.

© 2009 STMicroelectronics - All rights reserved

STMicroelectronics group of companies

Australia - Belgium - Brazil - Canada - China - Czech Republic - Finland - France - Germany - Hong Kong - India - Israel - Italy - Japan -
Malaysia - Malta - Morocco - Philippines - Singapore - Spain - Sweden - Switzerland - United Kingdom - United States of America

www.st.com

