

**Fast CMOS 3.3V 8-Bit
Transparent Latch**
Features

- Compatible with LCX™ and LVT™ families of products
- Supports 5V Tolerant Mixed Signal Mode Operation
 - Input can be 3V or 5V
 - Output can be 3V or connected to 5V bus
- Advanced Low Power CMOS Operation
- Excellent output drive capability:
Balanced drives (24 mA sink and source)
- Low ground bounce outputs
- Hysteresis on all inputs
- Industrial operating temperature range: -40°C to +85°C
- Packages available:
 - 20-pin 173 mil wide plastic TSSOP (L)
 - 20-pin 150 mil wide plastic QSOP (Q)
 - 20-pin 150 mil wide plastic TQSOP (R)
 - 20-pin 300 mil wide plastic SOIC (S)

Description

Pericom Semiconductor's PI74LPT series of logic circuits are produced in the Company's advanced 0.6 micron CMOS technology, achieving industry leading speed grades.

The PI74LPT573 is an 8-bit transparent latch designed with 3-state outputs and is intended for bus oriented applications. When Latch Enable (LE) is HIGH, the flip-flops appear transparent to the data. The data that meets the set-up time when LE is LOW is latched. When \overline{OE} is HIGH, the bus output is in the high impedance state.

The PI74LPT573 can be driven from either 3.3V or 5.0V devices allowing this device to be used as a translator in a mixed 3.3/5.0V system.

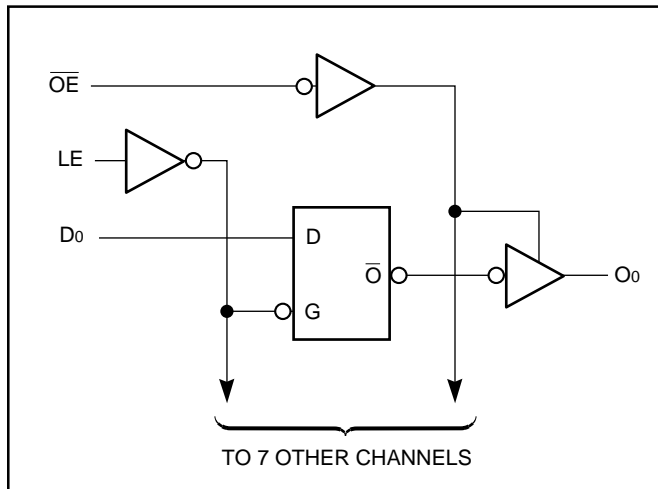
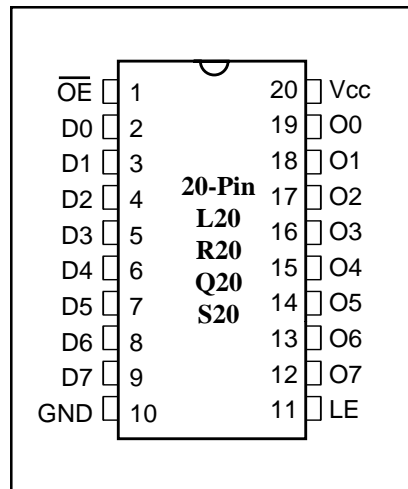
Logic Block Diagram

Pinout

Truth Table

Inputs ⁽¹⁾			Outputs ⁽¹⁾
D _N	LE	\overline{OE}	O _N
H	H	L	H
L	H	L	L
X	X	H	Z

Note:

1. H = High Voltage Level, X = Don't Care,
L = Low Voltage Level, Z = High Impedance

Pin Description

Pin Name	Description
\overline{OE}	Output Enable Input (Active LOW)
LE	Latch Enable Input (Active HIGH)
D7-D0	Data Inputs
O7-O0	3-State Outputs
GND	Ground
Vcc	Power

Maximum Ratings

(Above which the useful life may be impaired. For user guidelines, not tested.)

Storage Temperature	-65°C to +150°C
Ambient Temperature with Power Applied	-40°C to +85°C
Supply Voltage to Ground Potential (Inputs & Vcc Only)	-0.5V to +7.0V
Supply Voltage to Ground Potential (Outputs & D/O Only) ..	-0.5V to +7.0V
DC Input Voltage	-0.5V to +7.0V
DC Output Current	120 mA
Power Dissipation	1.0W

Note:

Stresses greater than those listed under MAXIMUM RATINGS may cause permanent damage to the device. This is a stress rating only and functional operation of the device at these or any other conditions above those indicated in the operational sections of this specification is not implied. Exposure to absolute maximum rating conditions for extended periods may affect reliability.

DC Electrical Characteristics (Over the Operating Range, $T_A = -40^\circ\text{C}$ to $+85^\circ\text{C}$, $V_{CC} = 2.7\text{V}$ to 3.6V)

Parameters	Description	Test Conditions ⁽¹⁾		Min.	Typ ⁽²⁾	Max.	Units
V _{IH}	Input HIGH Voltage (Input pins)	Guaranteed Logic HIGH Level		2.2	—	5.5	V
	Input HIGH Voltage (I/O pins)			2.0	—	5.5	V
V _{IL}	Input LOW Voltage (Input and I/O pins)	Guaranteed Logic LOW Level		-0.5	—	0.8	V
I _{IH}	Input HIGH Current (Input pins)	V _{CC} = Max.	V _{IN} = 5.5V	—	—	±1	µA
	Input HIGH Current (I/O pins)	V _{CC} = Max.	V _{IN} = V _{CC}	—	—	±1	µA
I _{IL}	Input LOW Current (Input pins)	V _{CC} = Max.	V _{IN} = GND	—	—	±1	µA
	Input LOW Current (I/O pins)	V _{CC} = Max.	V _{IN} = GND	—	—	±1	µA
I _{OZH}	High Impedance Output Current (3-State Output pins)	V _{CC} = Max.	V _{OUT} = 5.5V	—	—	±1	µA
I _{OZL}		V _{CC} = Max.	V _{OUT} = GND	—	—	±1	µA
V _{IK}	Clamp Diode Voltage	V _{CC} = Min., I _{IN} = -18 mA		—	-0.7	-1.2	V
I _{ODH}	Output HIGH Current	V _{CC} = 3.3V, V _{IN} = V _{IH} or V _{IL} , V _O = 1.5V ⁽³⁾		-36	-60	-110	mA
I _{ODL}	Output LOW Current	V _{CC} = 3.3V, V _{IN} = V _{IH} or V _{IL} , V _O = 1.5V ⁽³⁾		50	90	200	mA
V _{OH}	Output HIGH Voltage	V _{CC} = Min.	I _{OH} = -0.1 mA	V _{CC} -0.2	—	—	V
		V _{IN} = V _{IH} or V _{IL}	I _{OH} = -3 mA	2.4	3.0	—	V
		V _{CC} = 3.0V, V _{IN} = V _{IH} or V _{IL}	I _{OH} = -8 mA I _{OH} = -24 mA	2.4 ⁽⁵⁾ 2.0	3.0 —	— —	V
V _{OL}	Output LOW Voltage	V _{CC} = Min. V _{IN} = V _{IH} or V _{IL}	I _{OL} = 0.1 mA	—	—	0.2	V
			I _{OL} = 16 mA	—	0.2	0.4	V
			I _{OL} = 24 mA	—	0.3	0.5	V
I _{OS}	Short Circuit Current ⁽⁴⁾	V _{CC} = Max. ⁽³⁾ , V _{OUT} = GND		-60	-85	-240	mA
I _{OFF}	Power Down Disable	V _{CC} = 0V, V _{IN} or V _{OUT} ≤ 4.5V		—	—	±100	µA
V _H	Input Hysteresis			—	150	—	mV

Notes:

- For Max. or Min. conditions, use appropriate value specified under Electrical Characteristics for the applicable device type.
- Typical values are at V_{CC} = 3.3V, +25°C ambient and maximum loading.
- Not more than one output should be shorted at one time. Duration of the test should not exceed one second.
- This parameter is guaranteed but not tested.
- V_{OH} = V_{CC} - 0.6V at rated current.

Capacitance (T_A = 25°C, f = 1 MHz)

Parameters ⁽¹⁾	Description	Test Conditions	Typ.	Max.	Units
C _{IN}	Input Capacitance	V _{IN} = 0V	4.5	6	pF
C _{OUT}	Output Capacitance	V _{OUT} = 0V	5.5	8	pF

Note:

- This parameter is determined by device characterization but is not production tested.

Power Supply Characteristics

Parameters	Description	Test Conditions ⁽¹⁾		Min.	Typ ⁽²⁾	Max.	Units
I _{CC}	Quiescent Power Supply Current	V _{CC} = Max.	V _{IN} = GND or V _{CC}		0.1	10	μA
ΔI _{CC}	Quiescent Power Supply Current TTL Inputs HIGH	V _{CC} = Max.	V _{IN} = V _{CC} – 0.6V ⁽³⁾		2.0	30	μA
I _{CCD}	Dynamic Power Supply ⁽⁴⁾	V _{CC} = Max., Outputs Open \overline{OE} = GND One Bit Toggling 50% Duty Cycle	V _{IN} = V _{CC} V _{IN} = GND		50	75	μA/ MHz
I _C	Total Power Supply Current ⁽⁶⁾	V _{CC} = Max., Outputs Open f _i = 10 MHz 50% Duty Cycle \overline{OE} = GND One Bit Toggling	V _{IN} = V _{CC} – 0.6V V _{IN} = GND		0.6	2.3	mA
		V _{CC} = Max., Outputs Open f _i = 2.5 MHz 50% Duty Cycle \overline{OE} = GND 8 Bits Toggling	V _{IN} = V _{CC} – 0.6V V _{IN} = GND		2.1	4.7 ⁽⁵⁾	

Notes:

- For Max. or Min. conditions, use appropriate value specified under Electrical Characteristics for the applicable device.
- Typical values are at V_{CC} = 3.3V, +25°C ambient.
- Per TTL driven input; all other inputs at V_{CC} or GND.
- This parameter is not directly testable, but is derived for use in Total Power Supply Calculations.
- Values for these conditions are examples of the I_{CC} formula. These limits are guaranteed but not tested.
- I_C = I_{QUIESCENT} + I_{INPUTS} + I_{DYNAMIC}

$$I_C = I_{CC} + \Delta I_{CC} D_H N_T + I_{CCD} (f_{CP}/2 + f_i N_i)$$

I_{CC} = Quiescent Current (I_{CC1}, I_{CC2} and I_{CCZ})

ΔI_{CC} = Power Supply Current for a TTL High Input

D_H = Duty Cycle for TTL Inputs High

N_T = Number of TTL Inputs at D_H

I_{CCD} = Dynamic Current Caused by an Input Transition Pair (HLH or LHL)

f_{CP} = Clock Frequency for Register Devices (Zero for Non-Register Devices)

N_{CP} = Number of Clock Inputs at f_{CP}

f_i = Input Frequency

N_i = Number of Inputs at f_i

All currents are in milliamps and all frequencies are in megahertz.

Switching Characteristics over Operating Range⁽¹⁾

Parameters	Description	Conditions ⁽²⁾	LPT573		LPT573A		LPT573C		Units
			Com.		Com.		Com.		
			Min. ⁽³⁾	Max.	Min. ⁽³⁾	Max.	Min. ⁽³⁾	Max.	
tPLH tPHL	Propagation Delay Dx to Ox	CL = 50pF RL = 500Ω	1.5	8.0	1.5	5.2	1.5	4.2	ns
tPLH tPHL	Propagation Delay LE to Ox		2.0	12.0	2.0	8.5	2.0	5.5	ns
tpZH tpZL	Output Enable Time \overline{OE} to Ox		1.5	9.5	1.5	6.5	1.5	5.5	ns
tpHZ tPLZ	Output Disable Time ⁽⁴⁾ \overline{OE} to Ox		1.5	6.5	1.5	5.5	1.5	5.0	ns
tsu	Setup Time HIGH or LOW, Dx to LE		2.0		2.0		2.0		ns
th	Hold Time HIGH or LOW, Dx to LE		1.5		1.5		1.5		ns
tw	LE Pulse Width ⁽⁴⁾ HIGH		6.0		5.0		5.0		ns
tsk(o)	Output Skew ⁽⁵⁾			0.5		0.5		0.5	ns

Notes:

1. Propagation Delays and Enable/Disable times are with Vcc = 3.3V ±0.3V, normal range. For Vcc = 2.7V, extended range, all Propagation Delays and Enable/Disable times should be degraded by 20%.
2. See test circuit and waveforms.
3. Minimum limits are guaranteed but not tested on Propagation Delays.
4. This parameter is guaranteed but not production tested.
5. Skew between any two outputs, of the same package, switching in the same direction. This parameter is guaranteed by design.