

Technical Data Sheet

Rosenberger

BNC 50 Ω Adaptor
BNC 50 Ω Plug –
N 50 Ω Jack

51S153-K00N5

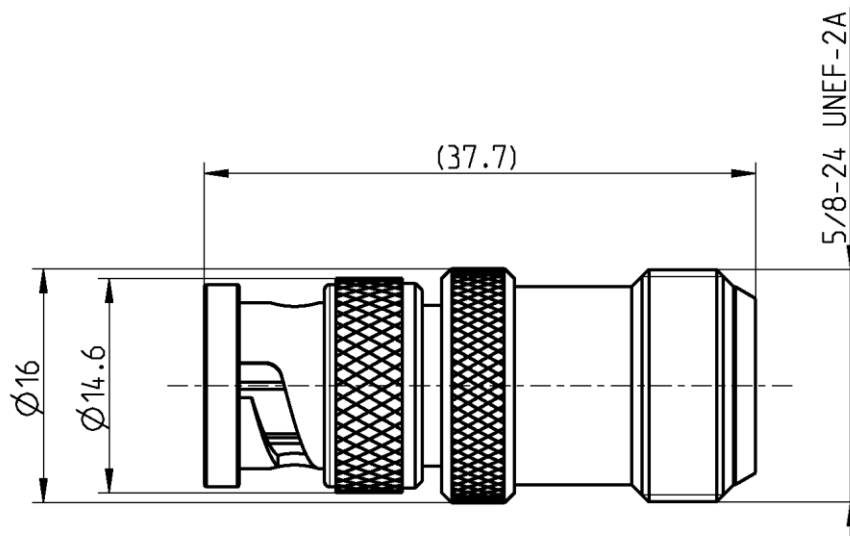

All dimensions are in mm; tolerances according to ISO 2768 m-H

Interface

According to	BNC side:	DIN EN 61169-8
	N side:	IEC 61169-16, MIL-PRF-39012, CECC 22210

Documents

N/A

Material and plating

Connector parts

Center contact BNC and N side
Outer contact BNC and N side
Body
Dielectric
Gasket

Material

CuBe
Brass
Brass
PTFE
NeopreneCR 50C6

Plating

AuroDur®, gold plated
Flash white bronze over silver(e.g. Optargen®)
Flash white bronze over silver(e.g. Optargen®)

BNC 50 Ω Adaptor
BNC 50 Ω Plug –
N 50 Ω Jack

51S153-K00N5

Electrical data

Impedance	50 Ω	
Frequency	DC to 10 GHz	
Return loss	≥ 35 dB, DC to 1 GHz	
	≥ 30 dB, 1 to 2.5 GHz	
	≥ 26 dB, 2.5 to 3 GHz	
Insertion loss	≤ 0.05 x √f [GHz] dB	
Insulation resistance	≥ 5 x10 ³ MΩ	
Center contact resistance	≤ 1.5 mΩ, BNC side;	≤ 1 mΩ, N side
Outer contact resistance	≤ 1 mΩ, BNC side;	≤ 0.25 mΩ, N side
Test voltage	1500 V rms	
Working voltage	400 V rms	
Power handling (at 20 °C, sea level, VSWR 1.0)	≤ 80 W @ 2 GHz	

Mechanical data

	BNC side	N side
Mating cycles	min. 500	min. 500
Center contact captivation: axial	≥ 28 N	≥ 28 N
Coupling test torque	N/A	max. 1.7 Nm
Recommended torque	N/A	0.7 Nm to 1.1 Nm

Environmental data

Temperature range	-55°C to +155°C
Thermal shock	MIL-STD-202, Meth. 107, Cond. B
Corrosion	MIL-STD-202, Meth. 101, Cond. B
Vibration	MIL-STD-202, Meth. 204, Cond. B
Shock	MIL-STD-202, Meth. 213, Cond. G
Moisture resistance	MIL-STD-202, Meth. 106
RoHS	compliant

Tooling

N/A

Suitable cables

N/A

Weight

Weight 31.9 g/pce

While the information has been carefully compiled to the best of our knowledge, nothing is intended as representation or warranty on our part and no statement herein shall be construed as recommendation to infringe existing patents. In the effort to improve our products, we reserve the right to make changes judged to be necessary.

For the installation of the electrotechnical equipment, particular electrotechnical expertise is required.



Draft	Date	Approved	Date	Rev.	Engineering change number	Name	Date
Chr. Entsfellner	17.07.08	Chr. Janßen	21.12.20	f00	20-1927	S. Huber-Siegl	21.12.20

Rosenberger Hochfrequenztechnik GmbH & Co. KG P.O.Box 1260 D-84526 Tittmoning Germany www.rosenberger.com	Tel. : +49 8684 18-0 Email : info@rosenberger.com	Page 2 / 2
--	--	---------------