

36V Boost LED Driver with PWM and single wire interface dimming UM1663S SOT23-6

General Description

The UM1663S is a highly integrated LED driver IC capable of driving 10 WLEDs in series. It is composed of a current mode boost converter integrated with a 38V/1A power switch.

The UM1663S supports a wide input voltage range from 2.8V to 5.5V and runs at a fixed frequency of 1MHz. The LED current is set via an external resistor and the feedback voltage is regulated to 200mV. During operation, the LED current is controlled by the duty cycle of the $\overline{\text{SHDN}}$ input signal, which determines the feedback reference voltage.

The UM1663S can modify dimming to support 64-step pulse dimming. More details are shown in the Timing Diagram section.

The UM1663S also has internal overvoltage protection setting to prevent the output from exceeding the absolute maximum ratings during open LED conditions. It is available in Green SOT23-6 package and operates over an ambient temperature range of -40°C to $+85^{\circ}\text{C}$.

Applications

- Mobile Phone and Smart Phone
- Digital Camera and GPS
- Portable DVD Player

Features

- High Output Voltage: Up to 36V
- Internal Soft-Start and Compensation
- 200mV Reference Voltage
- PWM Dimming and Frequency Range from 500Hz to 50kHz
- 64-Step Pulse Dimming
- Open LED Protection
- Internal Over Voltage Protection Setting
- Over Temperature Protection
- Current Limit Protection
- RoHS Compliant and Halogen Free

Typical Application Circuit

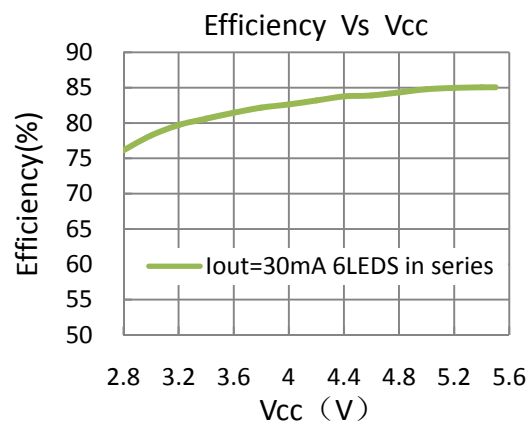
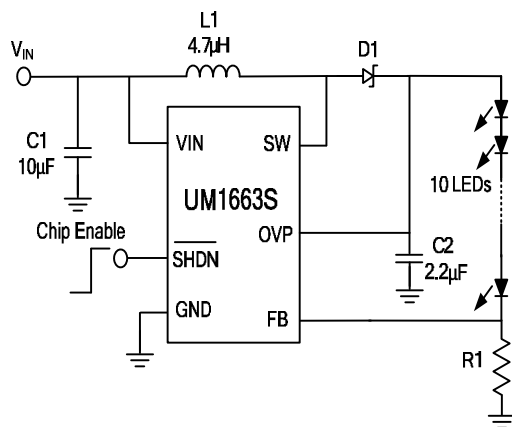

Pin Configurations

Top View

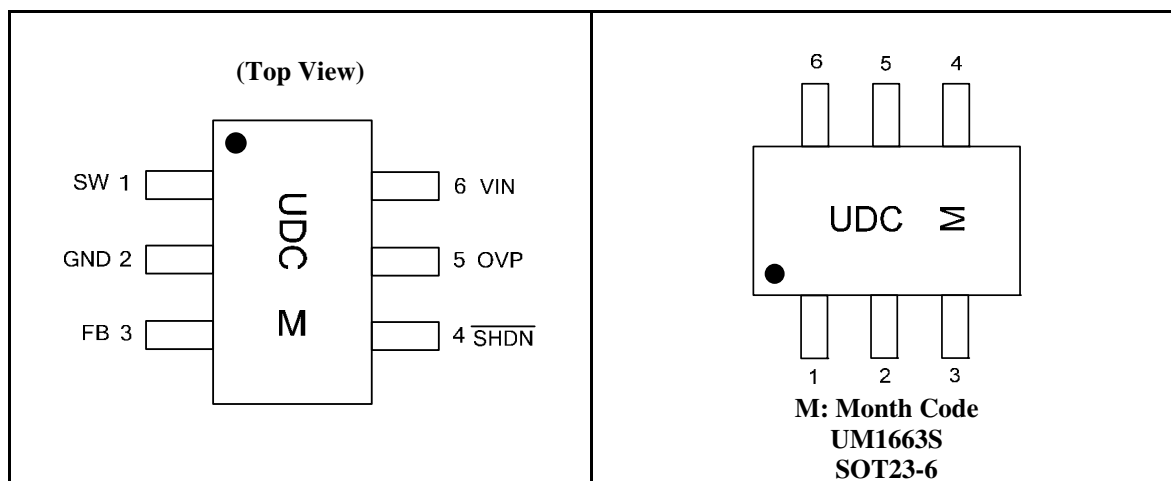

Ordering Information

Part Number	Packaging Type	Marking Code	Shipping Qty
UM1663S	SOT23-6	UDC	3000pcs/7Inch Tape & Reel

Pin Description

Pin Number	Symbol	Function
1	SW	Switch pin. Connect the inductor and the Schottky diode to this pin.
2	GND/PGND	Ground.
3	FB	Feedback voltage pin.
4	SHDN	Chip enable and PWM/Pulse mode dimming pin
5	OVP	Overvoltage protection pin. The pin is connected to an output capacitor to determine overvoltage of the chip. The default overvoltage threshold is 38V.
6	VIN	Supply voltage pin.

Absolute Maximum Ratings

Over operating free-air temperature (unless otherwise noted) (Note 1)

Symbol	Parameter	Value	Unit
V _{IN}	Supply Voltage on VIN (Note 2)	-0.3 to +6	V
V _{FB} , V _{/SHDN}	Voltages on FB, $\overline{\text{SHDN}}$ (Note 2)	-0.3 to +6	V
V _{SW} , V _{OVP}	Voltages on SW, OVP (Note 2)	-0.3 to +42	V
P _D	Power Dissipation at T _A = 25°C	0.684	W
	Power Dissipation at T _A = 70°C	0.447	
θ _{JA}	Package Thermal Resistance(Note 3)	190	°C/W
T _J	Operating Junction Temperature	+155	°C
T _{STG}	Storage Temperature Range	-65 to +150	°C
T _L	Maximum Lead Temperature for Soldering 10seconds	+260	°C

Note1: Stresses beyond those listed under absolute maximum ratings may cause permanent damage to the device. These are stress ratings only, and functional operation of the device at these or any other conditions beyond those indicated under recommended operating conditions is not implied. Exposure to absolute-maximum-rated conditions for extended periods may affect device reliability.

Note2: All voltage values are with respect to network ground terminal.

Note3: Junction to Ambient thermal Resistance is highly dependent on PCB layout.

Note4: θ_{JA} is measured in the convection at T_A=25°C(or T_A=70°C) on a High effective thermal conductivity test board of JESD51-7 thermal measurement standard

Note5: The maximum recommended junction temperature (T_J) of the UM1663S is 155°C, the thermal resistance of the UM1663S is θ_{JA}=190°C/W, specified regulator operation is assured to a maximum ambient temperature T_A of 25°C. there for the maximum power dissipation is calculated as below:

$$P_{D(\text{MAX})} = (T_{J(\text{MAX})} - T_A) / \theta_{JA} = (155 - 25) / 190 = 0.684\text{W}$$

Note 6: The device is not guaranteed to function properly beyond absolute maximum ratings.

Electrical Characteristics

($V_{IN}=3.7V$, $\overline{SHDN}=VIN$, $T_A = -40^{\circ}C$ to $85^{\circ}C$, typical value are at $T_A = 25^{\circ}C$, unless otherwise noted)

Symbol	Parameter	Test Conditions	Min	Typ	Max	Unit
V_{IN}	Input Voltage Range		2.8		5.5	V
I_Q	Operating Quiescent Current	Not switching, $V_{FB}=0.3V$		600		μA
		Switching, $V_{FB}=0.1V$		1.2	3	mA
I_{SD}	Shutdown Current	$\overline{SHDN}=GND$		0.5	2	μA
V_{UVLO}	Under-voltage Lockout Threshold		2	2.2	2.45	V
	UVLO Hysteresis			0.1		V
V_{IH}	\overline{SHDN} High Level Input Voltage	$VCC=3.7V$	1.5			V
		$VCC=5V$	1.8			
V_{IL}	\overline{SHDN} Low Level Input Voltage	$VCC=3.7V$			0.6	V
		$VCC=5V$			0.8	
I_L	\overline{SHDN} Input Leakage Current	$\overline{SHDN}=GND$ or VIN		0.1	1	μA
		\overline{SHDN} Dimming Frequency		500		50K
	\overline{SHDN} Shut Down Delay Time		20			ms
	\overline{SHDN} Pulse Dimming Time	Logic High	0.5			μs
		Logic Low	0.5			μs
V_{SW}	Maximum Switch Voltage			40		V
f_{OSC}	OSC Frequency			1		MHz
D_{MAX}	Maximum Duty			93		%
$R_{DS(ON)}$	MOSFET On-Resistance			550		m Ω
	MOSFET Leakage Current	$V_{SW}=38V$		1	10	μA
I_{LIM}	MOSFET Current Limit		0.8	1	1.2	A
V_{OUT}	Adjustable Output Voltage Range		V_{IN}		36	V
V_{REF}	Internal Voltage Reference	$2.5V \leq V_{IN} \leq 5.5V$	190	200	210	mV
	Over Voltage Protection			36		V
	Over Temp Protection			155		$^{\circ}C$
	OTP Hysteresis			25		$^{\circ}C$

ESD AND LATCH UP PERFORMANCE					
I/O Pin ESD-Protection Voltage		Human Body Model		±2	KV
LatchUpPerformance		JEDEC Standard No.78E		±200	mA

Pulse/PWM Dimming Timing Diagram

For the UM1663S, dimming method is determined by the length of the initial pulse period.

If initial pulse width $\geq 2\text{ms}$, the UM1663S will be set to PWM dimming.

If initial pulse width $\leq 1.5\text{ms}$, then UM1663S will be set to Pulse dimming.

For pulse dimming logic high time T_{IH} of $\overline{\text{SHDN}}$ should $> 0.5\mu\text{s}$, logic low time T_{IL} should be between $0.5\mu\text{s} \sim 500\mu\text{s}$.

If $\overline{\text{SHDN}}$ is logic low $> 20\text{ms}$, both in Pulse dimming and PWM dimming mode UM1663S is shutdown.

PWM Dimming

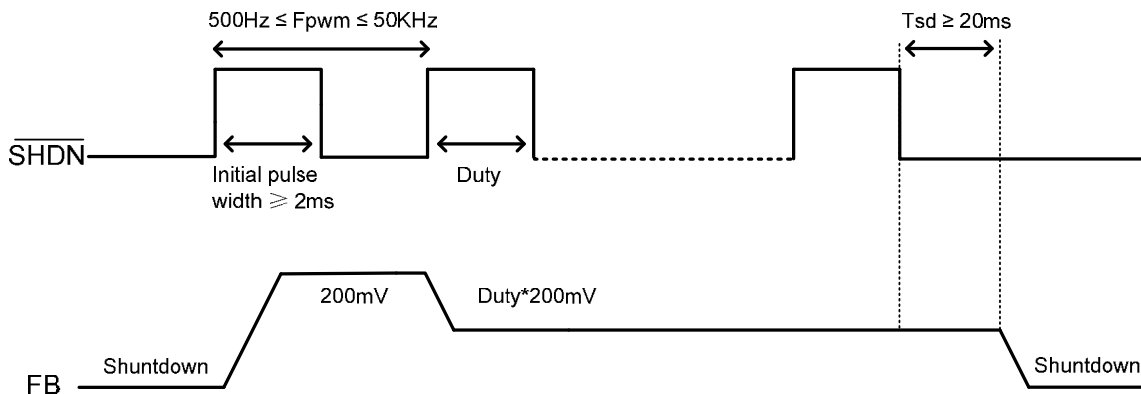

Figure 1. UM1663S PWM dimming

Pulse Dimming

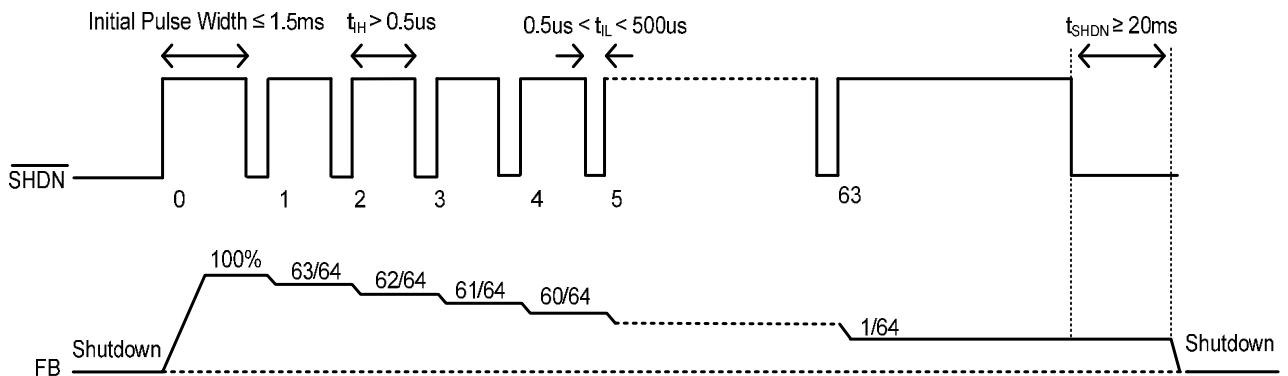
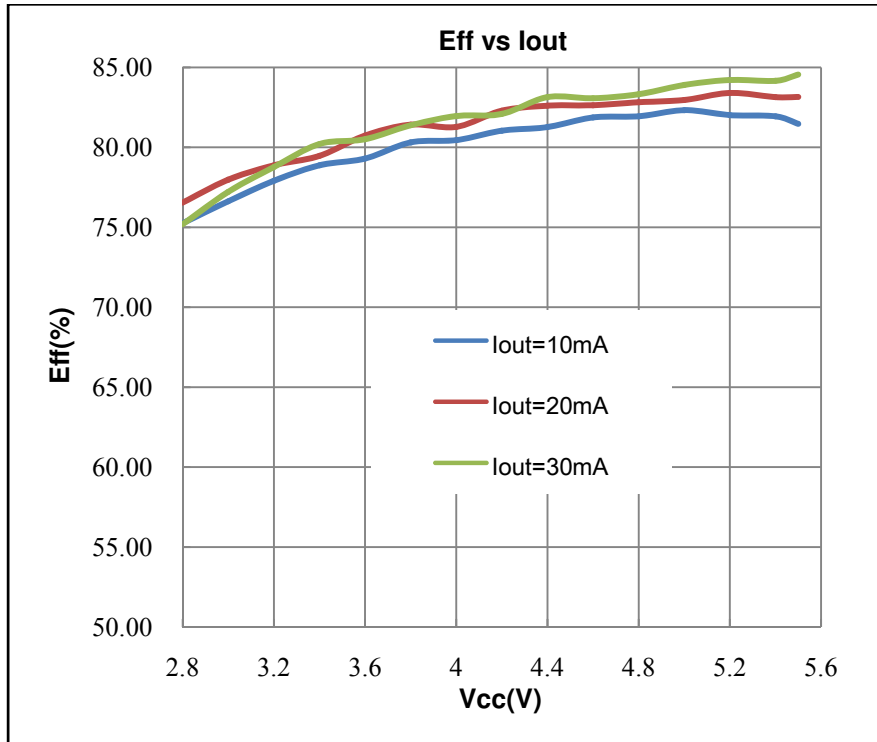
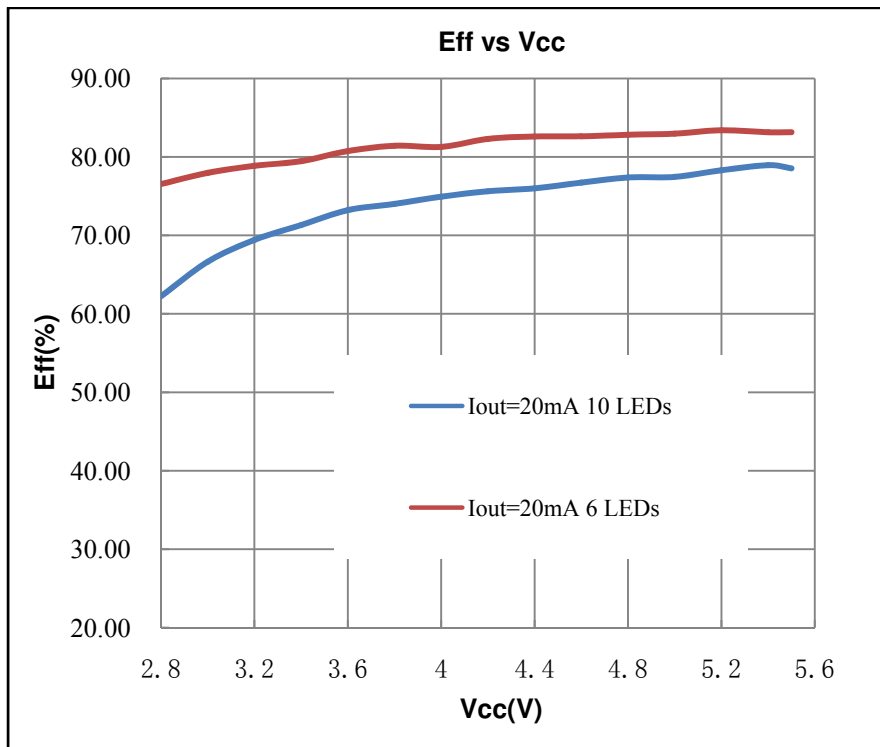

Figure 2. UM1663S pulse dimming

Typical Operating Characteristics



Efficiency Waveform (Vcc=3.6V 6 WLED String)



Efficiency Waveform

Typical Operating Characteristics

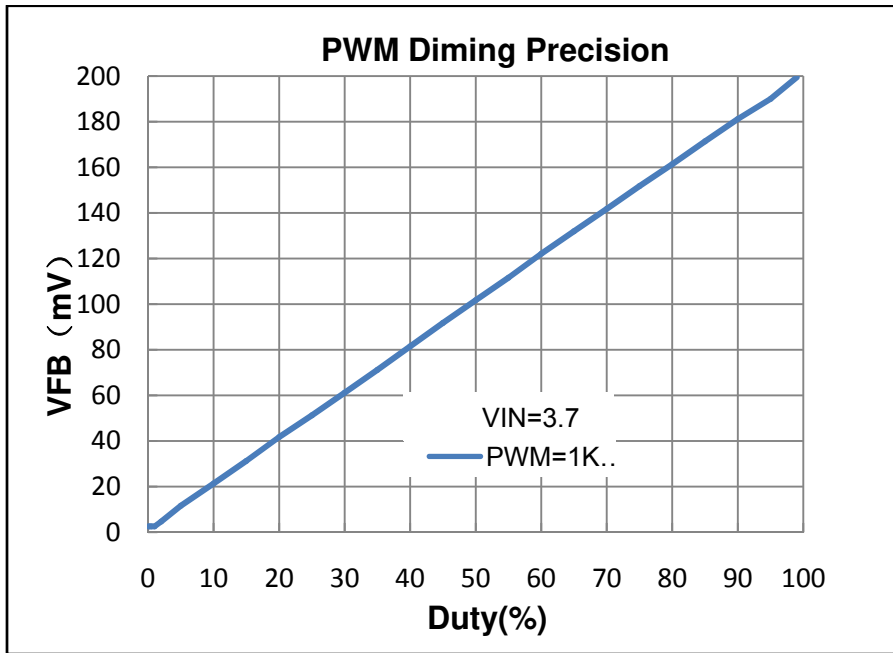

PWM Dimming Pulse vs V_{FB} Voltage Curve

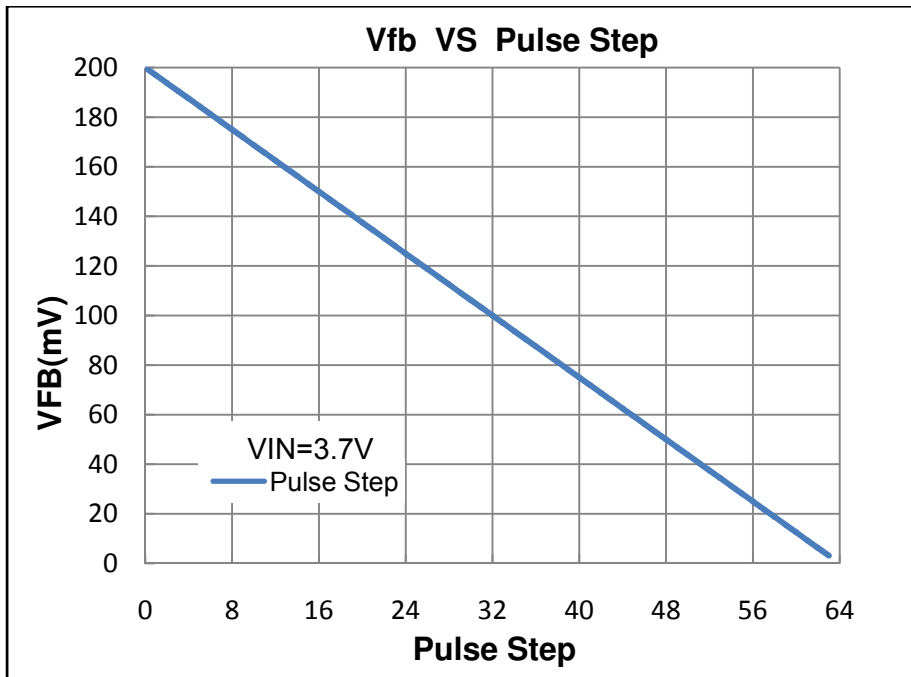

Pulse Dimming Pulse Step vs V_{FB} Voltage Curve

Typical Operating Characteristics

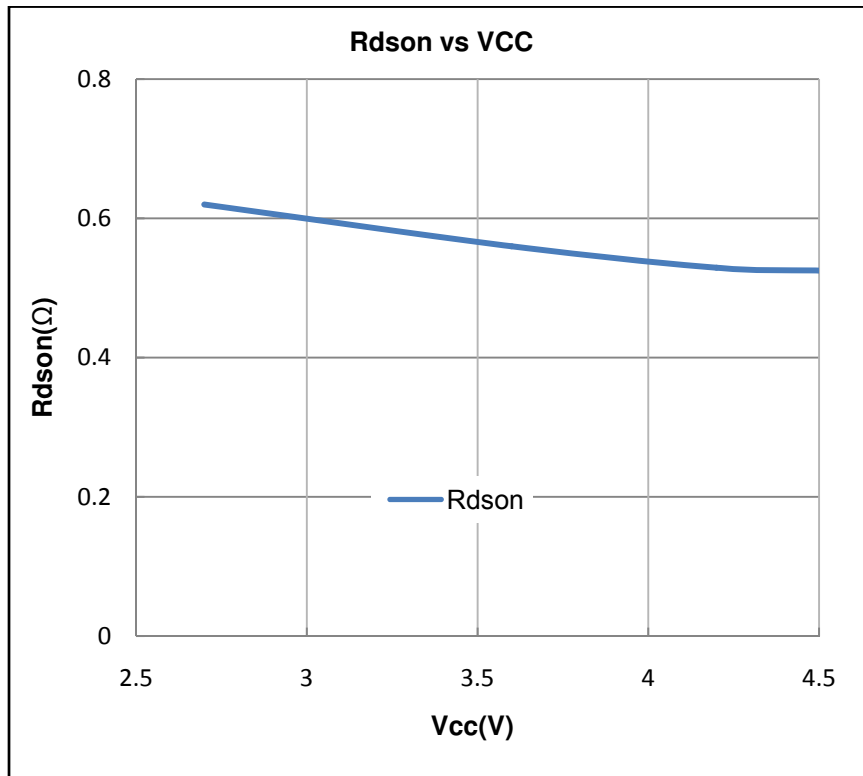

Internal Power NMOS Rds(on) Vs VCC Curve

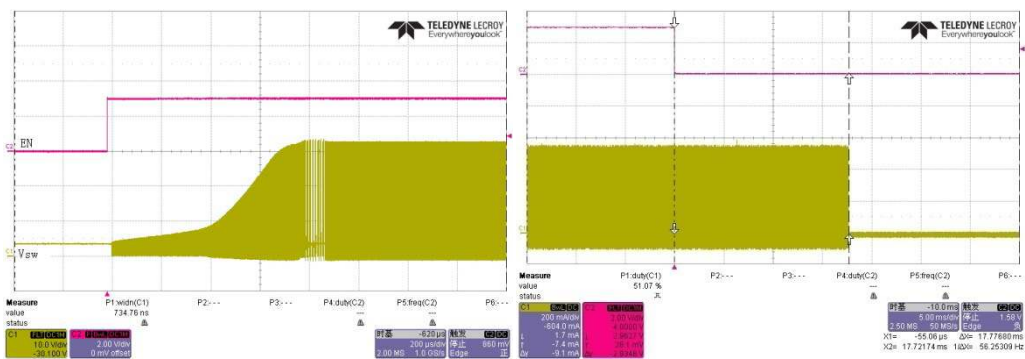

Power ON from EN

Power OFF from EN

Typical Operating Characteristics

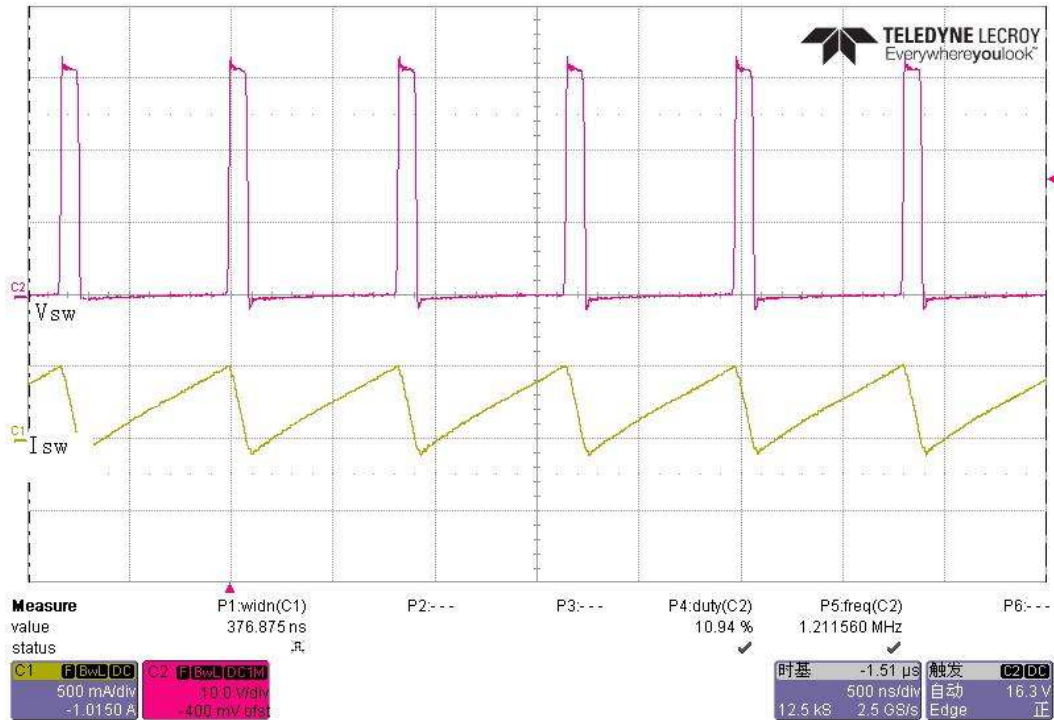

Vsw&Isw Waveform(VCC=3.6V Iout=20mA 10 WLED String)

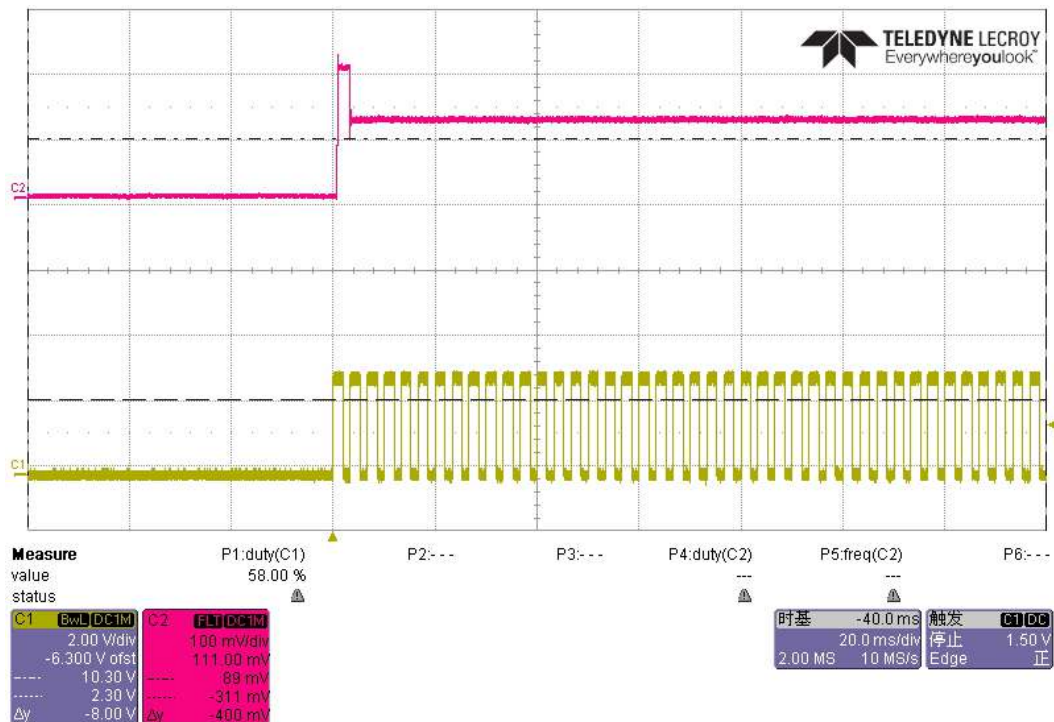

PWM Dimming

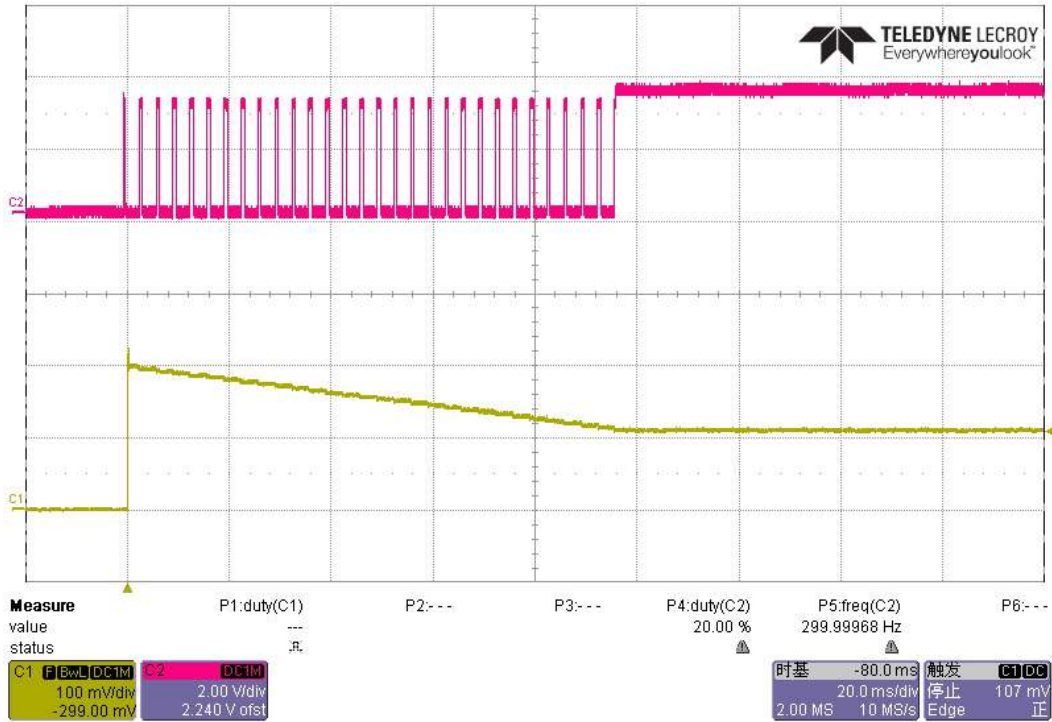

Pulse Dimming

Function Block Diagram

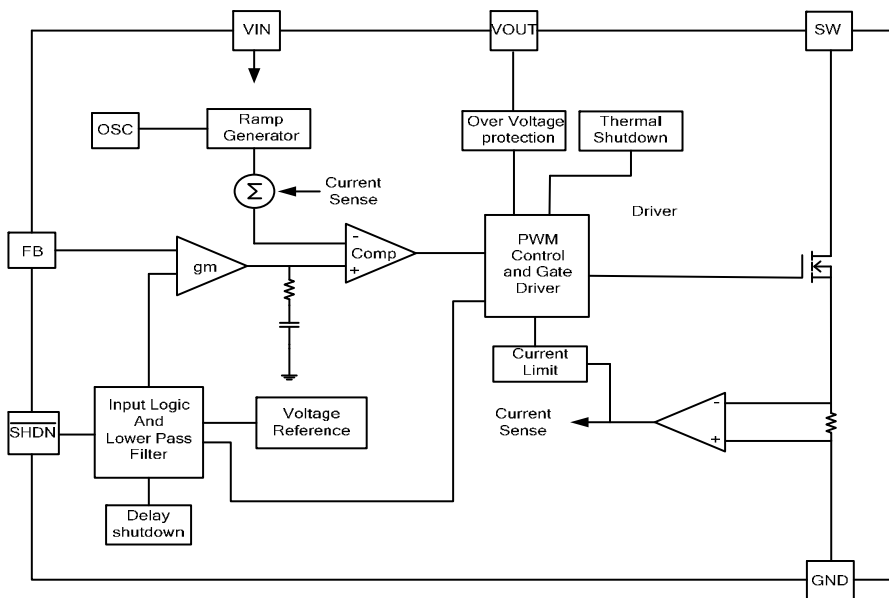

Figure 3. UM1663S function block diagram

Functional Description

The UM1663S uses PWM current-mode boost converter architecture to control the LED current by regulating the feedback voltage. Refer to functional block diagram. The beginning of each cycle turns on the Power MOSFET. A slope compensation ramp is added to the output of the current sense amplifier and the result is fed into the positive input of the comparator (COMP). When this voltage goes above the output voltage of the error amplifier (gM), the Power MOSFET is turned off. The voltage at the output of the gM block amplifies the difference between the reference voltage and the feedback voltage (VFB), so that FB pin voltage can be regulated to the reference voltage.

The UM1663S has built-in soft start to limit the inrush current during startup and to limit the amount of overshoot on the output. Protection features include internal over-voltage protection(OVP), cycle-by-cycle current limit protection and thermal shutdown protection. OVP protects in the event where an LED fails open, which forces the feedback voltage to zero. This causes the boost converter to operate in maximum duty cycle mode, ramping up the output voltage. Switching will stop when the output reaches the OVP threshold. The OVP feature protects the IC from damaging itself by exceeding the voltage rating on LX pins.

Typical Application Circuit

The UM1663S could drive different WLED topology. For example Figure 4 shows the 3*7 WLEDs and the current is equal to 90mA. The total WLEDs current could be set by the Rset which is equal to following equation:

$$I_{total} = 200mV/R1$$

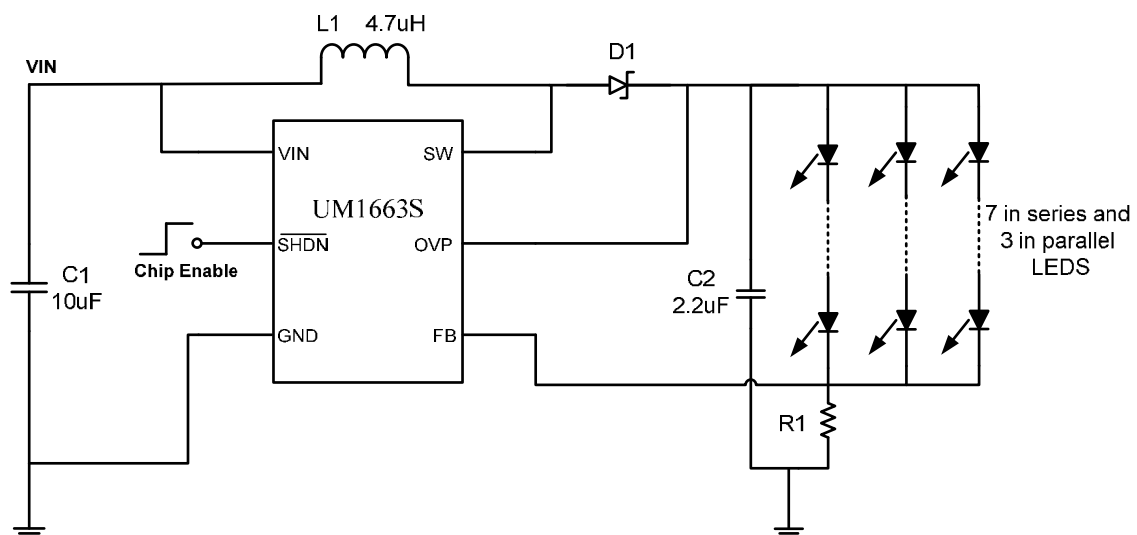

Figure 4. UM1663S driving 7 in series and 3 in parallel LEDs

Low input voltage application

In application that have low input voltage range(Figure5),such as those powered from 1AA cells, the UM1663S may still be used if there is a suitable system supply (such as 3.3V) available to power the controller.In such an application,the inductor may be connected directly

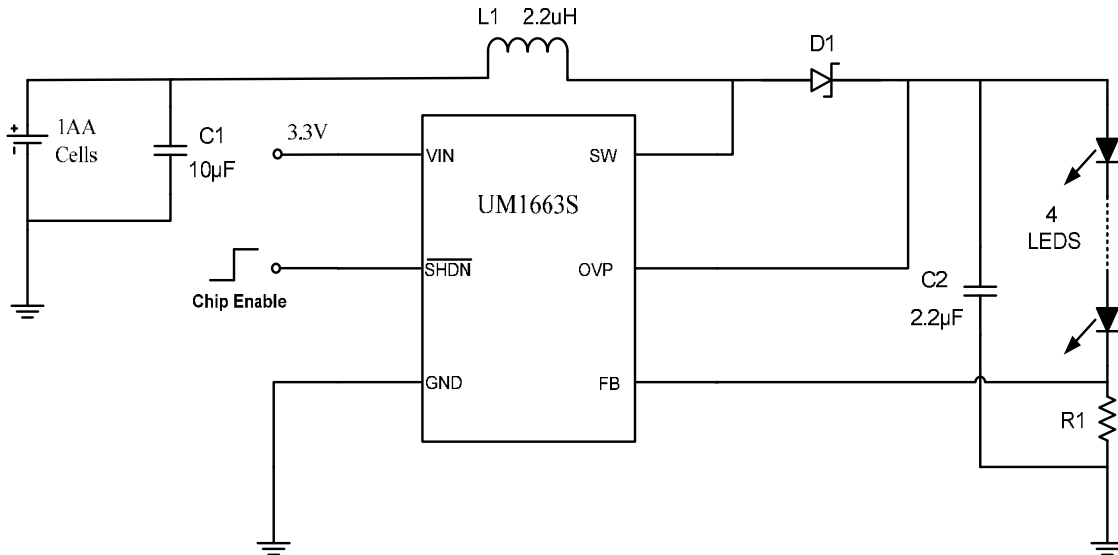

Figure 5. Using UM1663S to drive LED strings power from 1AA Cell

High input voltage application

In applications that UM1663S have high input voltage range(Figure6),such as those power form a series connected Li-ion batteries. The UM1663S could be used if there is a suitable system supply available (such as 3.3V) to power the controller,or use high input voltage LDO such as UM1460-33 to generate a 3.3V power supply from Li-ion battery. In such cases, the inductor could be connected directly to the battery while the UM1663S power is supply by the system supply or output of LDO UM1460-33.

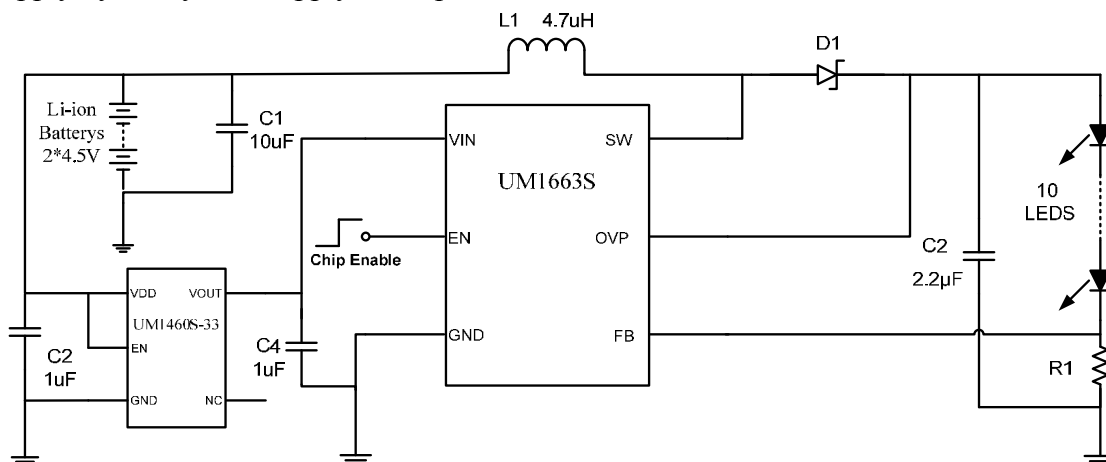

Figure 6. UM1663S based LED driver circuit powered from high input voltage

Applications Information

Soft-Start

The UM1663S includes a soft-start function to avoid high inrush current during start up.

LED Current

The loop control of the boost converter keeps V_{FB} equal to a reference voltage, V_{REF} . Therefore, when RSET is connected between the FB pin and GND, the LED current will be determined by the current through R_{SET} , which is equal to V_{FB} / R_{SET} .

Pulse/PWM Dimming

For the UM1663S, dimming method is determined by the length of the initial pulse period.

If initial period $\leq 1.5ms$, the UM1663S will be set to pulse dimming.

If initial period $\geq 2ms$, the UM1663S will be set to PWM dimming. The detail operation of brightness dimming is shown in the Figure 1&Figure 2.

When adding the PWM signal to the \overline{SHDN} pin, the UM1663S is turned on or off by the PWM signal, so the LEDs operate at either zero or full current. The average LED current increase proportionally with the duty cycle of the PWM signal. The magnitude of the PWM signal should be higher than the maximum enable voltage of the \overline{SHDN} pin, in order to let the dimming control perform correctly. The recommended frequency range of the PWM signal is from 500Hz to 50kHz.

Once selection has been made, the dimming method may not be changed until system shutdown, even if the dimming frequency is modified.

Current Limiting

The current flowing through the inductor during a charging period is detected by a current sensing circuit. If the value is over the current limit, the N-MOSFET will be turned off. The inductor will then be forced to leave charging stage and enter discharging stage. Therefore, the inductor current will not increase over the current limit.

Shutdown Delay

When the \overline{SHDN} voltage is in logic low for 20ms (min.) during pulse dimming, the system will enter shutdown.

OVP/UVLO/OTP

When the output voltage is higher than a specified value or input voltage is lower than a specified value, the IC will enter protection mode. If the die temperature $> 155^{\circ}C$, the IC will also enter protection mode. During protection mode, the P-MOSFET is turned off to prevent abnormal operation.

Inductor Selection

The recommended Inductor value for 10 WLEDs applications is $4.7\mu H$. Small size and better efficiency are the major concerns for portable devices, such as for mobile phone. The inductor should have low core loss at 1MHz and low DCR for better efficiency. The inductor saturation current rating must be greater than the inductor peak current.

Capacitor Selection

$10\mu F$ input ceramic capacitor and $2.2\mu F$ output ceramic capacitor are recommended for driving 10 WLEDs applications. For better voltage filtering, ceramic capacitors with low ESR are recommended. X5R and X7R types are suitable because of their wide voltage and temperature

Diode Selection

Using a schottky diode is recommended in UM1663 application because of its low forward

voltage drop and fast reverse recovery time. The current rating of the schottky diode should exceed the peak current of the boost converter. The voltage rating should also exceed the target output voltage.

Layout Consideration

PCB layout is very important for high frequency switching regulators in order to keep the loop stable and minimize noise. The input capacitor should be very close to the IC to get the best decoupling. The path of the inductor, schottky diode and output capacitor should be kept as short as possible to minimize noise and ringing. FB is a sensitive node and it should be kept separate from the SW switching node in the PCB layout.

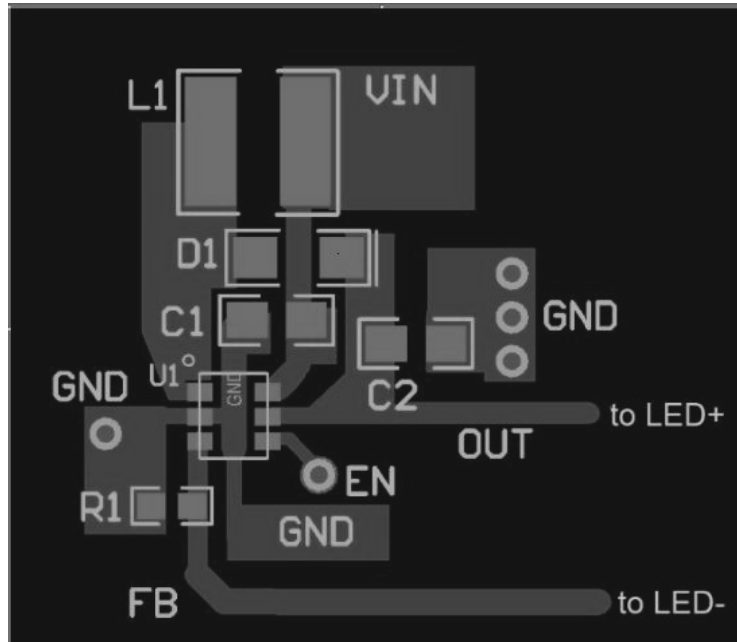

Thermal Consideration

For continuous operation, do not exceed absolute maximum junction temperature. The maximum power dissipation depends on the thermal resistance of the IC package, PCB layout, rate of surrounding airflow, and difference between junction and ambient temperature. The maximum power dissipation can be calculated by the following formula:

$$P_{D(MAX)} = (T_{J(MAX)} - T_A) / \theta_{JA}$$

where $T_{J(MAX)}$ is the maximum junction temperature, T_A is the ambient temperature, and θ_{JA} is the junction to ambient thermal resistance.

For recommended operating condition specifications of the UM1663S, the maximum junction temperature is 155°C and T_A is the ambient temperature. The junction to ambient thermal resistance, θ_{JA} , is layout dependent.

The maximum power dissipation depends on the operating ambient temperature for fixed $T_{J(MAX)}$ and thermal resistance, θ_{JA} .

Package Information

UM1663S: SOT23-6

Outline Drawing

Symbol	DIMENSIONS			
	MILLIMETERS		INCHES	
	Min	Max	Min	Max
A	1.050	1.250	0.041	0.049
A1	0.000	0.100	0.000	0.004
A2	1.050	1.150	0.041	0.045
b	0.300	0.500	0.012	0.020
c	0.100	0.200	0.004	0.008
D	2.820	3.020	0.111	0.119
E	1.500	1.700	0.059	0.067
E1	2.650	2.950	0.104	0.116
e	0.950REF		0.037REF	
e1	1.800	2.000	0.071	0.079
L	0.600REF		0.023REF	
L1	0.300	0.600	0.012	0.024
θ	0°	8°	0°	8°

Land Pattern

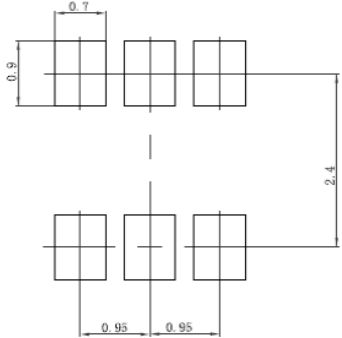
	<p>NOTES:</p> <ol style="list-style-type: none"> 1. Compound dimension: 2.92×1.60 ; 2. Unit: mm; 3. General tolerance ±0.05mm unless otherwise specified; 4. The layout is just for reference.
---	--

Tape and Reel Orientation

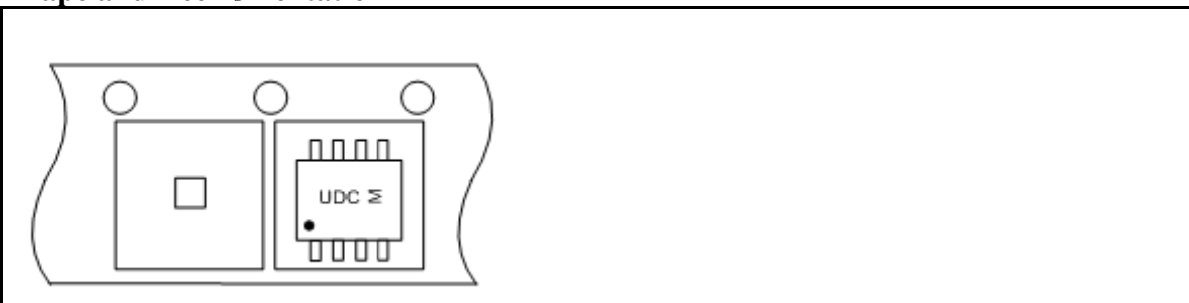

GREEN COMPLIANCE

Union Semiconductor is committed to environmental excellence in all aspects of its operations including meeting or exceeding regulatory requirements with respect to the use of hazardous substances. Numerous successful programs have been implemented to reduce the use of hazardous substances and/or emissions.

All Union components are compliant with the RoHS directive, which helps to support customers in their compliance with environmental directives. For more green compliance information, please visit:

http://www.union-ic.com/index.aspx?cat_code=RoHSDeclaration

IMPORTANT NOTICE

The information in this document has been carefully reviewed and is believed to be accurate. Nonetheless, this document is subject to change without notice. Union assumes no responsibility for any inaccuracies that may be contained in this document, and makes no commitment to update or to keep current the contained information, or to notify a person or organization of any update. Union reserves the right to make changes, at any time, in order to improve reliability, function or design and to attempt to supply the best product possible.