



Standard PM Step Motors

PM35S-048-HHC6

Step Angle: 7.5°

Model Specifications

Model:	PM35S-048-HHC6
Shaft Length:	10mm
Wire Length:	300mm fly lead (no connector)
Wire Holder:	90 deg. Left
Front Plate:	FPH
Electrical:	24V, 600mA
	Bipolar Constant Current
	5.5 ohms, MS70M

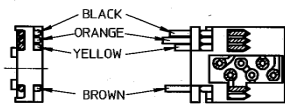

WIRE COLOR CODE

WIRE COLOR	MOTOR
BLACK	A1
BROWN	A3
ORANGE	B1
YELLOW	B3

MARKING

NMB-MAT PM35S-048-HHC6
JAPAN H9806
<JAPAN>

NMB-MAT PM35S-048-HHC6
THAILAND TA9806
<THAILAND>

COLOR	BLACK	ORANGE	BROWN	YELLOW
STEP				
1	-	+	+	-
2	-	-	+	+
3	+	-	-	+
4	+	+	-	-

SWITCHING SEQUENCE
(VIEWED FROM MOUNTING SURFACE)

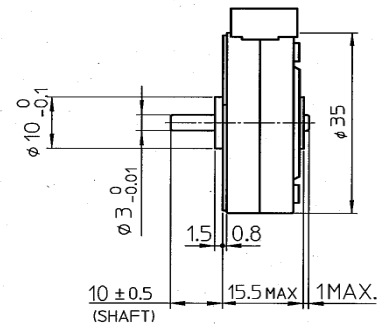
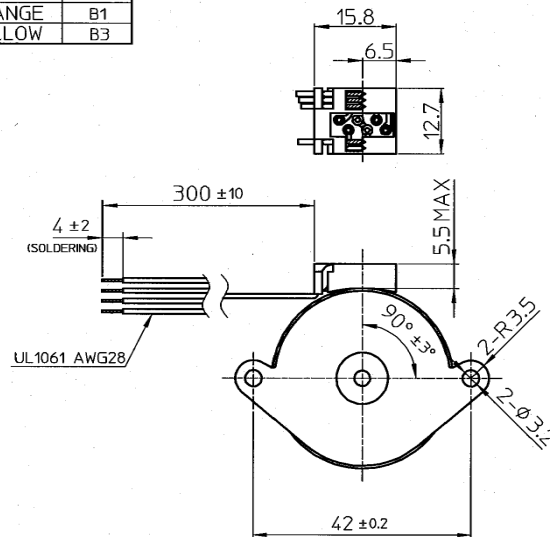



Standard PM Step Motors

PM35S-048-HHC6

DYNAMIC TORQUE CHARACTERISTICS (No. 62788)

(ALL VALUES ARE GAINED BY MEASUREMENT AND NOT SPECIFICATIONS VALUES)

Model : PM35S-048-HHC6
 Drive Mode : BIPOLAR CHOPPER
 Drive Voltage : 24.0 V
 Method : 2-2P
 Drive IC : UDN2917EB
 Surge/Current : / 600 mA / Phase (Peak)
 Coil Resistance : 5.5 Ω
 Magnet Material : MS70M
 Stator Material : SECC

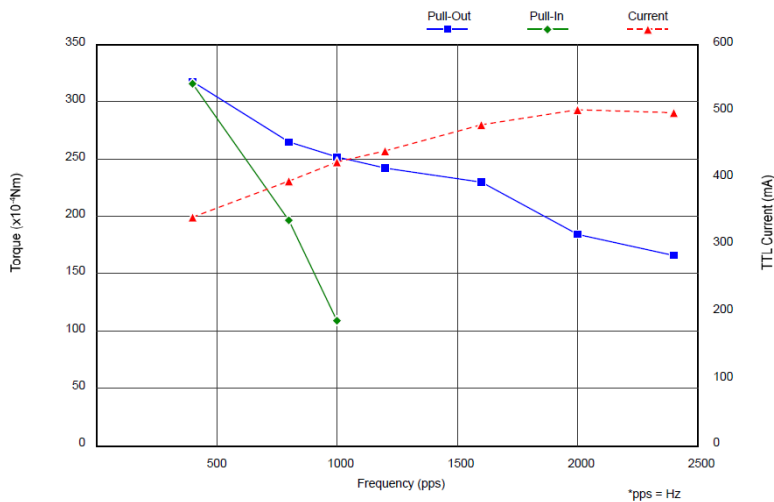

(TTL Current = Over all current drawn by the driver)

Frequency (pps)	400	800	1000	1200	1600	2000	2400
■ Pull-Out (x10 ⁻⁴ Nm)	316.8	264.8	252.0	242.2	229.5	184.4	165.7
◆ Pull-In (x10 ⁻⁴ Nm)	315.8	196.1	108.9				
▲ Current (mA)	342	395	424	440	479	502	498

Minebea Motor Manufacturing Corporation