

THIS INFORMATION IS CONFIDENTIAL AND PROPRIETARY TO TYCO ELECTRONICS CORPORATION AND ITS WORLDWIDE
 SUBSIDIARIES AND AFFILIATES. IT MAY NOT BE DISCLOSED TO ANYONE, OTHER THAN TYCO ELECTRONICS PERSONNEL,
 WITHOUT WRITTEN AUTHORIZATION FROM TYCO ELECTRONICS CORPORATION, HARRISBURG PENNSYLVANIA USA

PROPRIETARY:

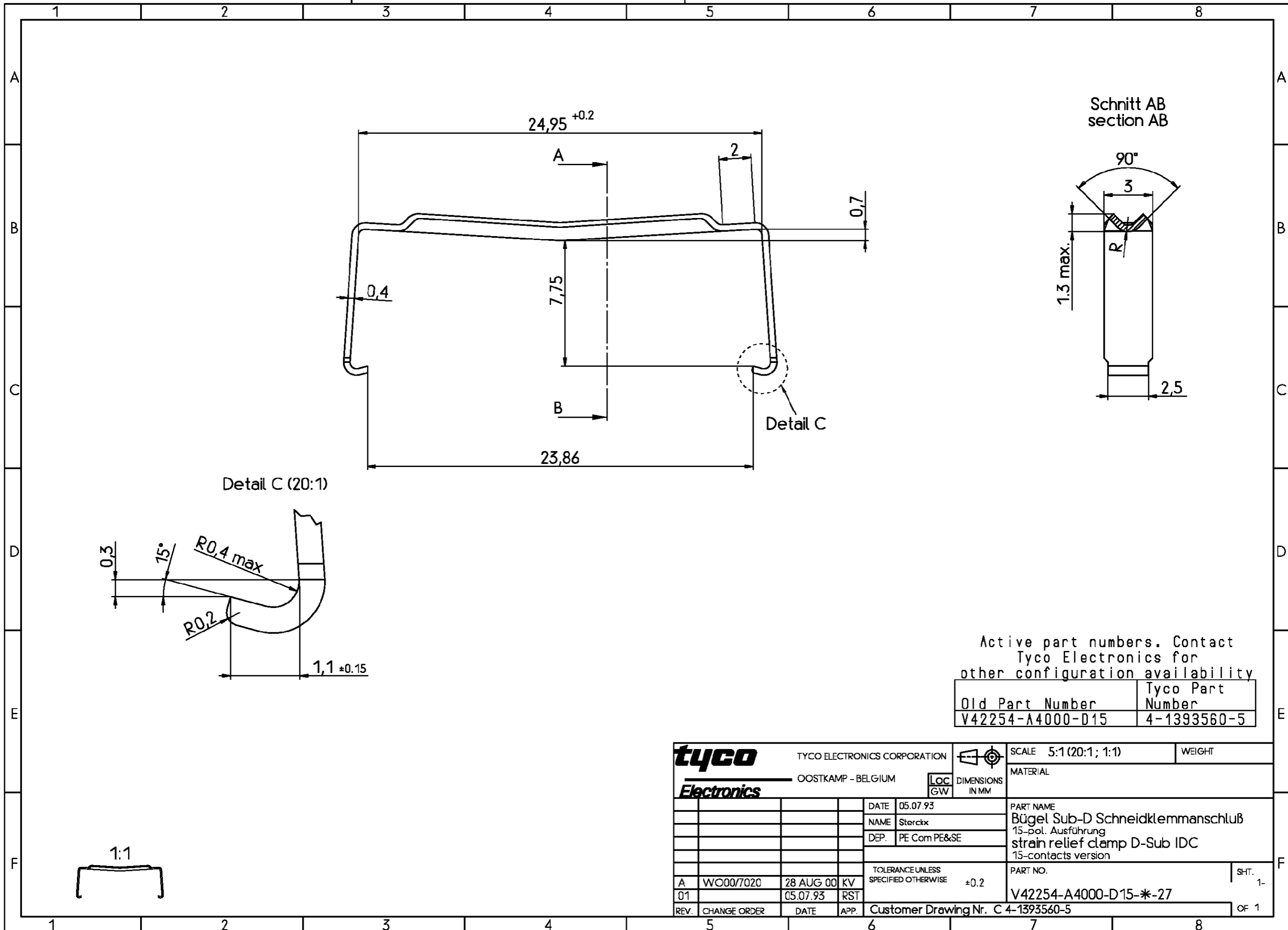

Active part numbers. Contact
 Tyco Electronics for
 other configuration availability

Old Part Number	Tyco Part Number
V42254-A4000-D15	4-1393560-5

tyco TYCO ELECTRONICS CORPORATION		SCALE 5:1 (20:1; 1:1)		WEIGHT	
OOSTKAMP - BELGIUM		DIMENSIONS IN MM		MATERIAL	
LOC GW		DATE 05.07.93		PART NAME	
		NAME Sterckx		Bügel Sub-D Schneidklemmanschluß	
		DEP. PE Com PE&SE		15-pol. Ausführung	
				strain relief clamp D-Sub IDC	
				15-contacts version	
		TOLERANCE UNLESS SPECIFIED OTHERWISE ±0.2		PART NO.	
A WO00/7020		28 AUG 00 KV		V42254-A4000-D15-*27	
01		05.07.93 RST		SHT. 1-	
REV. CHANGE ORDER		DATE APP.		Customer Drawing Nr. C 4-1393560-5	
				OF 1	