

## IS6607A Evaluation Board User Guide

### EVM Schematic

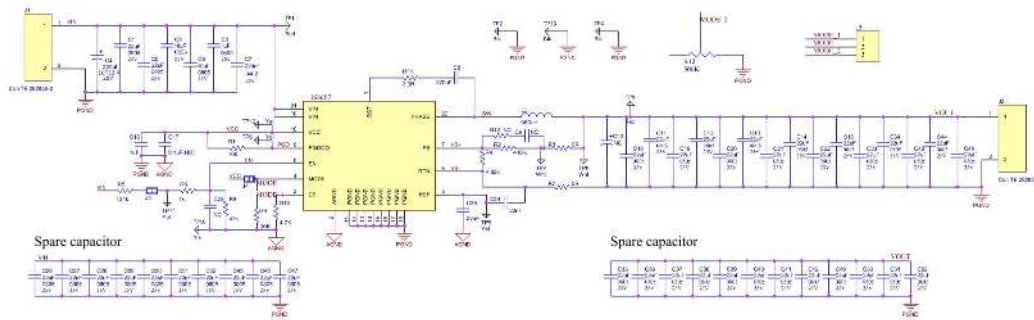

**Note:**

- 1) This schematic design is based on  $V_{IN}=12V$ ,  $V_{OUT}=1.2V$ .
- 2) PGGOOD is an indicator of system fault (including UV, OV, OC and OT). If it is not needed, remove R1 to float PGGOOD.
- 3) EN is used to enable the IC. It is connected via a resistor divider from  $V_{in}$  (to generate 3.3V). If EN is supplied by external signal, remove J3 jumper and connect it directly to the external enable signal.
- 4) The current limit for this EVM is set at 25.5A. If needed, the current limit can be changed using the

Comment	Description	Designator	Footprint	LibRef	Quantity	
50A	Input output connectors	PGND, PGND, VIN, VOUT	Header - 2x3 - 5mm	Power interface_pin 6	4	
22uF	SMD Capacitor 0805	C1, C5, C11, C12, C13, C14, C15, C18, C19, C20, C21, C22, C33, C34, C43, C44, C48	C0805_SMALL	Capacitor 0805	17	
22uF	SMD Capacitor 0805	C26, C27, C28, C29, C30, C31, C32, C35, C36, C37, C38, C39, C40, C41, C42, , C45, C46, C47, C49, C50, C51, C52	C0805_SMALL	Capacitor 0805	22	NC
10uF	SMD Capacitor 0805	C2, C6	C0805_SMALL	Capacitor 0805	2	
1uF	SMD Capacitor 0603	C3	C0603_SMALL	Capacitor 0603	1	
220u	Capacitor Alum Poly, 220uF, 25V, 20% SMD	C4	WCAP-PSLC 10x12.4x4.5	220uF, 25V, Alum Polymer, +/-20%	1	
220nF	SMD Capacitor 0402	C7, C8	RC0402_SMALL	Capacitor 0402	2	
3.3nF	SMD Capacitor 0402	C9	RC0402_SMALL	Capacitor 0402	1	NC
220uF	T55B227M6R3C0025	C10	DFN3528	220uF, 6.3V, Polymer Cap	1	NC
1uF	SMD Capacitor 0402	C16	RC0402_SMALL	Capacitor 0402	1	
0.1uF	SMD Capacitor 0402	C17	RC0402_SMALL	Capacitor 0402	1	NC
1uF	SMD Capacitor 0402	C23	RC0402_SMALL	Capacitor 0402	1	NC
22nF	SMD Capacitor 0402	C24, C25	RC0402_SMALL	Capacitor 0402	2	
Header 1x3	Con Header 2Pos .100" Gold	J5	Header - 1x3 - 100mil	Header 1x3	1	
Header 1x2	Con Header 2Pos .100" Gold	J3, J4	Header - 1x2 - 100mil	Header 1x2	2	
0.68uH	Inductor,0.68uH,20A,3.3 mohm	L1	1040	MCF-1040-1R0-N2	1	

10k	SMD Resistor 0402	R1	RC0402_SMALL	Resistor 0402	1	
4.02K	SMD Resistor 0402	R2, R4	RC0402_SMALL	Resistor 0402	2	
0R	SMD Resistor 0402	R3, R7	RC0402_SMALL	Resistor 0402	2	
121k	SMD Resistor 0402	R5	RC0402_SMALL	Resistor 0402	1	
1k	SMD Resistor 0402	R6	RC0402_SMALL	Resistor 0402	1	
47k	SMD Resistor 0402	R8	RC0402_SMALL	Resistor 0402	1	
30k	SMD Resistor 0402	R9	RC0402_SMALL	Resistor 0402	1	
4.7K	SMD Resistor 0402	R10	RC0402_SMALL	Resistor 0402	1	
3.3R	SMD Resistor 0402	R11	RC0402_SMALL	Resistor 0402	1	
500K	Potentiometer	R12	RM065	Resistor_adjustable	1	
0R	SMD Resistor 0402	R13	RC0402_SMALL	Resistor 0402	1	NC
Red	Test point, Red, .062 hole	TP1, TP5	TP-RED	Test Pont - Red	2	
Blk	Test point, Black, .062 hole	TP2, TP4, TP10, TP13	TP-BLK	Test Pont - Blk	4	
Yel	Test point, Yellow, .062 hole	TP6, TP9, TP11, TP12	TP-YEL	Test Pont - Yellow	4	
IS6607A	IC	U1	IS6607A QFN21	IS6607A	1	

## Configuration and Operation

The IS6607A Eval Board has designed all necessary connections and test points to test and evaluate its performance. Before operation, make sure that all external power supplies and loads are disabled or turned off.

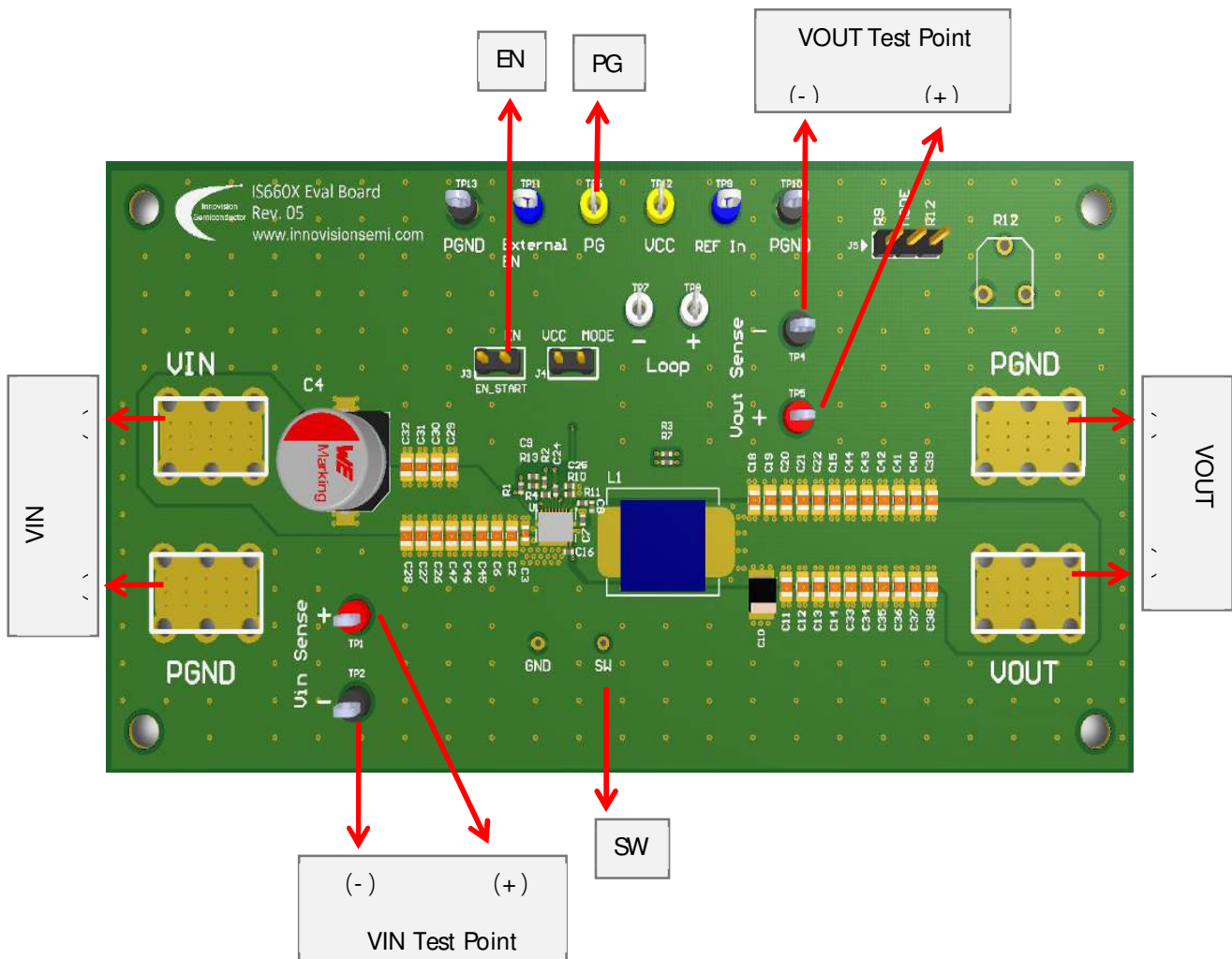

## Power On

It is assumed that all power supplies and active loads are preset to proper output and load conditions, and all connections are made.

- 1) Ensure that all power supply voltages are turned off.
- 2) VIN input 12V.
- 3) Connect the J3 jumper cap or apply 3V to 5V to the "EN".  
external point shown to make the circuit work normally.
- 4) Use electronic load (0-20A).
- 5) Power off in reverse order.

When measuring efficiency, it is recommended to use a precision shunt and a multimeter with more than 5 digits to measure current and voltage. If the above conditions are met, your efficiency results should be accurate.

## Change Settings

Users can change four settings on IS6607A Eval Board:

Step 1. Output voltage

Step 2. Current limitation

Step 3. Soft start time

Step 4. Switching frequency

Step 1. To change the output voltage, use the following equation to calculate. R2 is the top resistor (from VOUT to FB) and R4 is the bottom resistor (from FB to GND). Reference to the table below for actual resistor value.

$$V_{OUT} = \frac{R_2 + R_4}{R_4} \times 0.6V$$

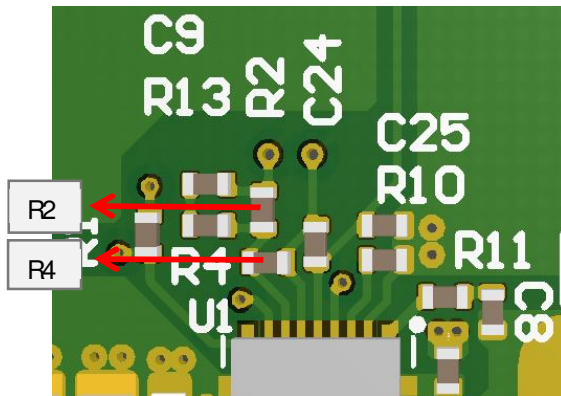

$V_{OUT} (V)$	$R_{top} (K\Omega)$	$R_{bot} (K\Omega)$
1.0	2	3
1.2	4.02	4.02
1.8	4.02	2
3.3	8.2	1.8
5	8.2	1.1

Step 2. To change current limit, use the following equation to determine the desired R10 value.

$$I_{LIM}(A) = \frac{V_{OCP}}{R_{CS} \times G_{CS}} + \frac{V_{OUT} \times (V_{IN} - V_{OUT})}{V_{IN}} \times \frac{1}{2 \times L \times f_s}$$

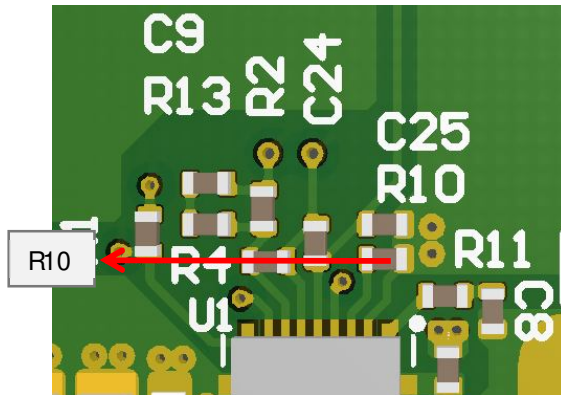

The inductor current information is reflected to the CS pin by Gcs.

$$V_{OCP} = 1.2V$$

$$G_{CS} = 10\mu A/A$$

Step 3. In order to change Soft Start time, use the following equation to calculate.

$$T_{SS}(ms) = \frac{C_{REF}(nF) \times 0.6(V)}{36(\mu A)}$$

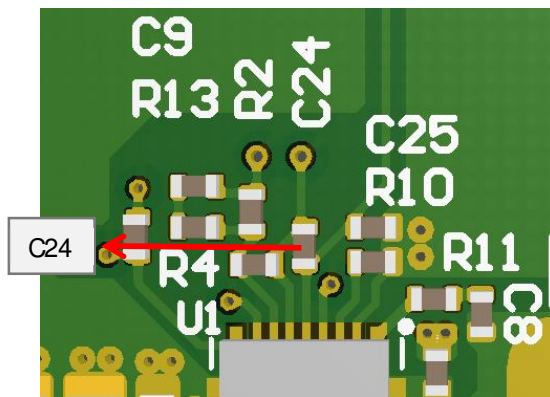

SS time is set at default of 1 msec. Adding a small MLCC capacitor between REF and RTN can extend the soft start time.

Step 4. In order to change the switching frequency of the EVM, the IC must be turned off or power removed first.

## MODE Selection

MDOE	Light-Load Mode	Switching Frequency
VCC	Pulse skip	600KHz
243kΩ(±20%) to GND	Pulse skip	800KHz
121kΩ(±20%) to GND	Pulse skip	1000KHz
GND	Forced CCM	600KHz
30.1kΩ(±20%) to GND	Forced CCM	800KHz
60.4kΩ(±20%) to GND	Forced CCM	1000KHz

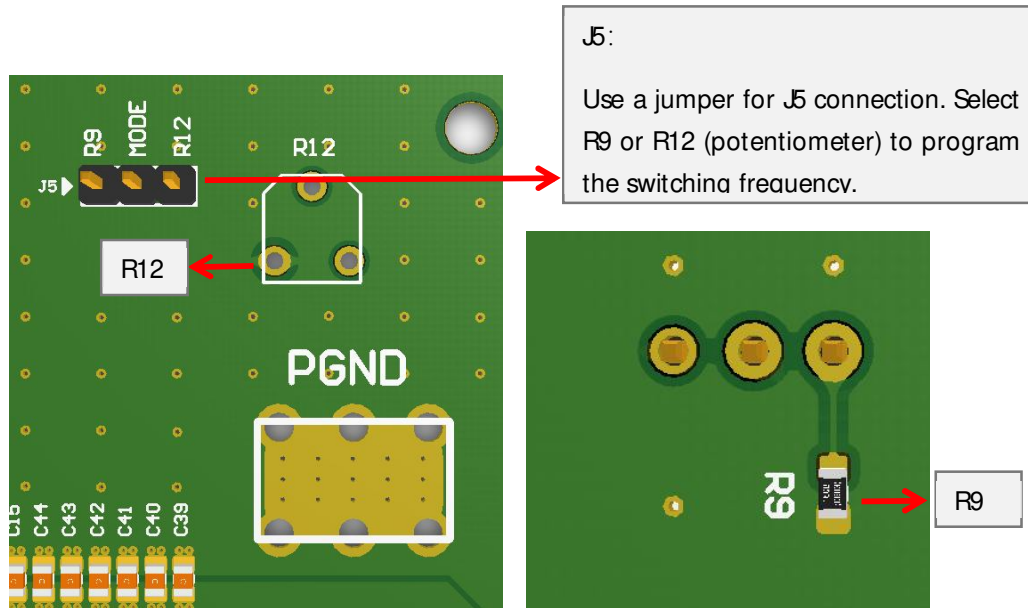



## PCB Layout Guidelines:

An effective PCB layout is critical to the stable operation of the circuit. For best performance, please refer to the diagram in the PCB layout column and follow the PCB layout recommendations below.

- 1) The input ceramic capacitor should be as close as possible to the VIN and PGND pins, and the main ceramic capacitor should be placed on the same wiring layer as IS6607A. VIN and PGND of copper plane should be a maximum of make parasitic resistance is minimized .
- 2) Vin (pin 10) must be connected to a capacitance value close to the minimum 0.1 $\mu$ F capacitor. At least two 20/10 mil vias connected to the ground terminal of the capacitor is connected to the PCB ground.
- 3) Place as many PGND holes as possible closest to the PGND pin to minimize parasitic impedance and thermal resistance.
- 4) The VCC capacitor should be as close as possible to IS6607A. Connect AGND and PGND at the ground point of the VCC capacitor.

- 5) Place the BST capacitor as close as possible to BST and SW.  
The wiring width should be greater than 20mm. We recommend the use of 0.1  $\mu\text{F}$  - 1  $\mu\text{F}$  of the capacitor. The resistor is placed between the IC and BST capacitor. It is recommended to use a 3.3  $\Omega$  resistor.
- 6) Place the REF capacitor close to REF and connect to RTN.  
22 nF is recommended to use a capacitor.
- 7) If the via must be placed on the PGOOD pin , place it at least 10 mm away from the positive side of the 1st input decoupling capacitor near IS6607A .

## PCB Layout Example

### 1) TOP Layer

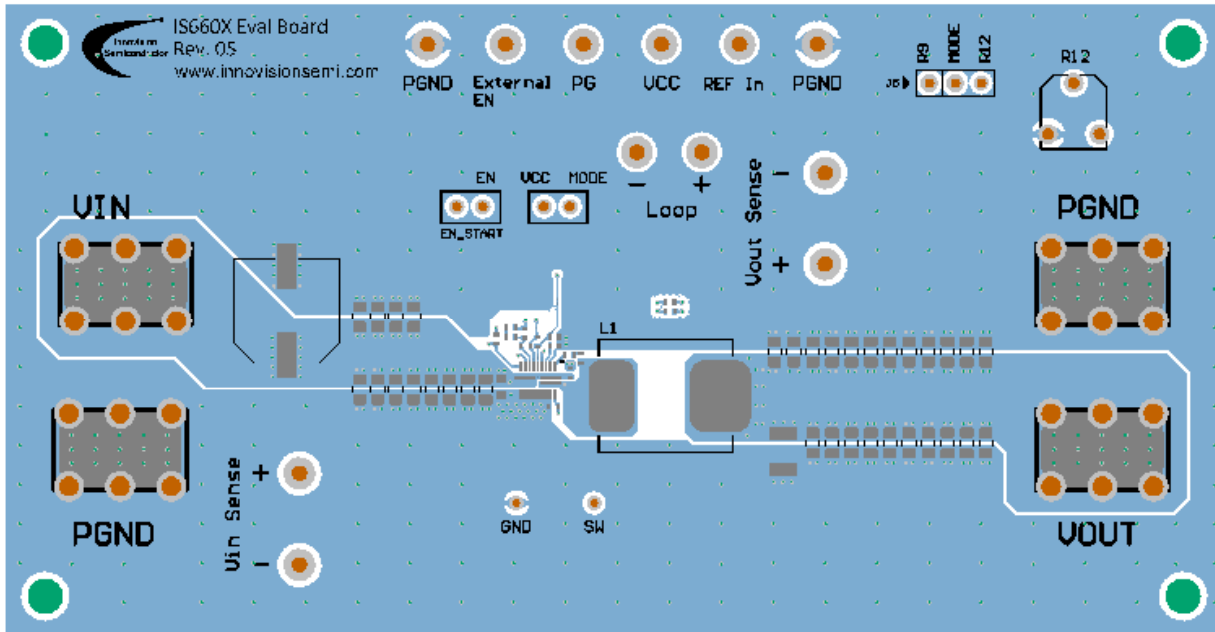

### 2) Layer 2

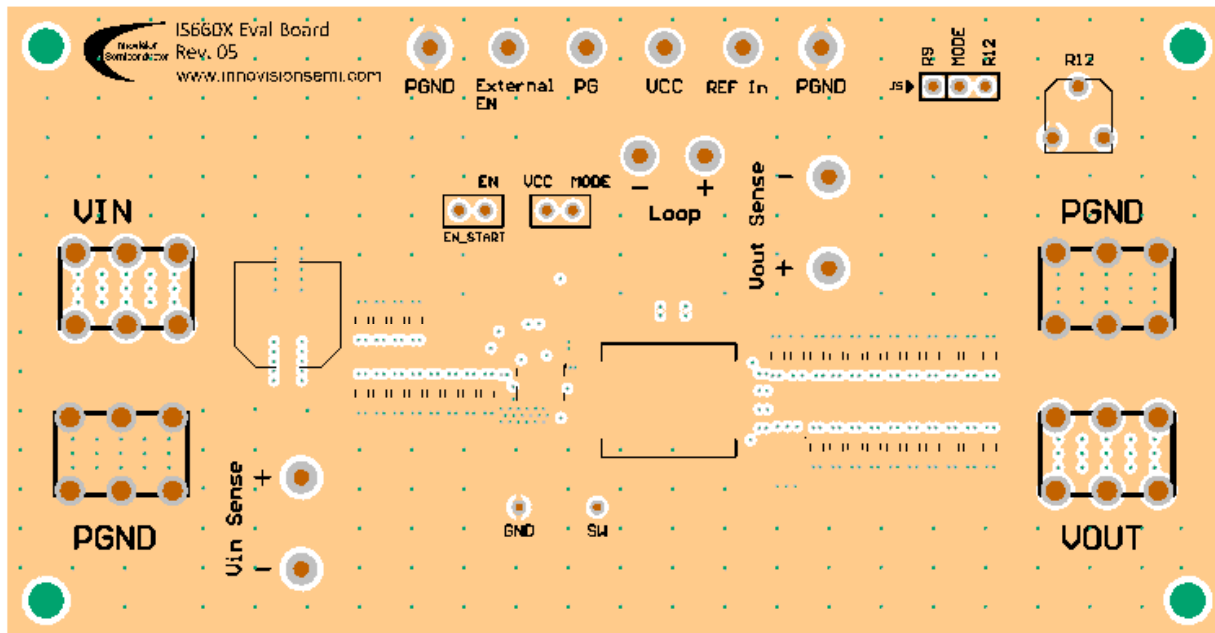

## 3) Layer 3

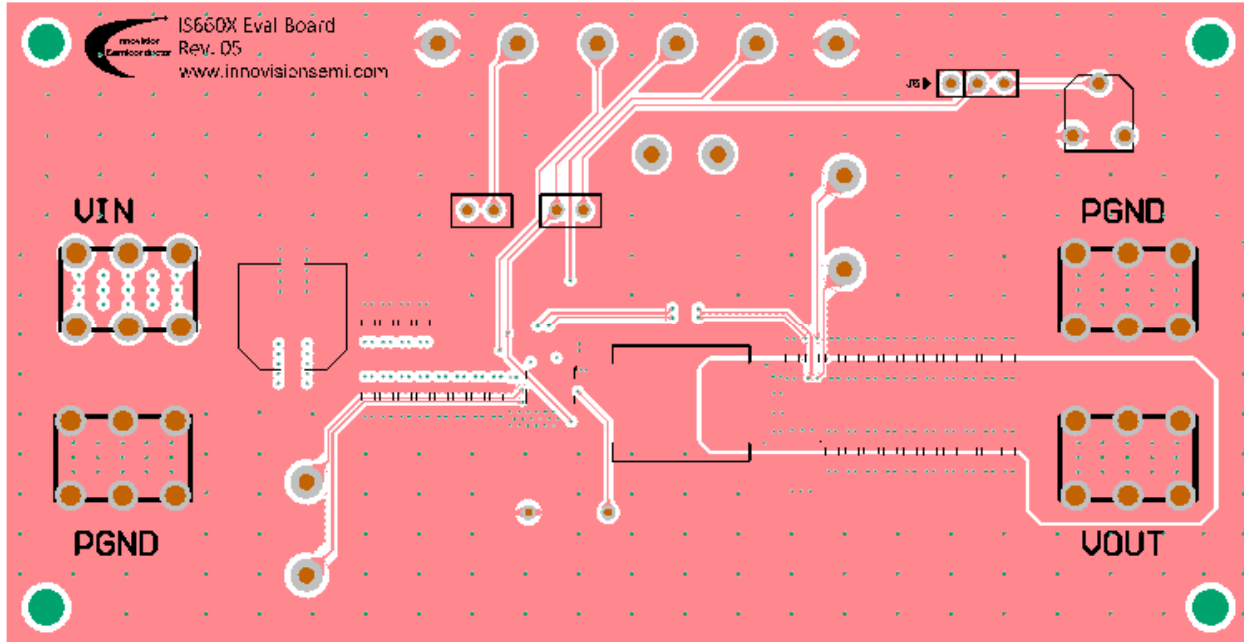

## 4) Bottom Layer

