



Introducing
G13 Style SMT Assembly
and End Cap Cover

G13 Style SMT Assembly and End Cap Cover

KEY FEATURES

- 2 Position G13 Style SMT Assembly
- The End Cap Cover is designed to interface with G13 Style SMT assembly, heat sink and tube. (Custom configurations are available upon special request.)
- End Cap Cover packaged unassembled
- 0.5 inch pin centerline per G13 specification
- The surface mount hold down provides stability during tube insertion and extraction
- High temperature material for reflow processing
- The G13 Style SMT Assembly is compatible with FR4 and aluminum clad boards
- The G13 Style SMT Assembly is tape and reel packaged for high speed SMT processing
- RoHS compliant

DESCRIPTIONS

The G13 Style SMT Assembly and End Cap Cover are designed for use on printed circuit board LED strip lighting modules in T8 and T12 fluorescent retrofit LED tubes.

APPLICATIONS

Standard T8 and T12 fluorescent fixtures

ELECTRICAL

Operating Current : 2 AMPS

Operating Voltage : 250VAC/250VDC

Dielectric Withstanding Voltage : 1500VAC

MECHANICAL

Operating Temperature : -40°C to 120°C

Mating Cycles : 10

MATERIALS

G13 Style SMT Assembly : UL 94 V0 rated high temperature resistant thermoplastic

End cap cover : UL 94 V0 Thermoplastic

Contacts : Tin plated brass

SMT hold down : Tin plated brass

STANDARDS AND SPECS

114-13255 : G13 Style SMT Assembly & End Cap Application Specification

108-2393 : G13 Style SMT Assembly & End Cap Product Specification

ETL Recognized, File No. 3177705CRT-001 to UL 8750 and UL 1993 Standards

PRODUCT OFFERING

2106646-1 : End Cap Cover (T8 sized tube applications)

2106150-1 : G13 Style SMT Assembly

G13 Style SMT Assembly and End Cap Cover

PRODUCT DIMENSIONS

PIN 2106150-1

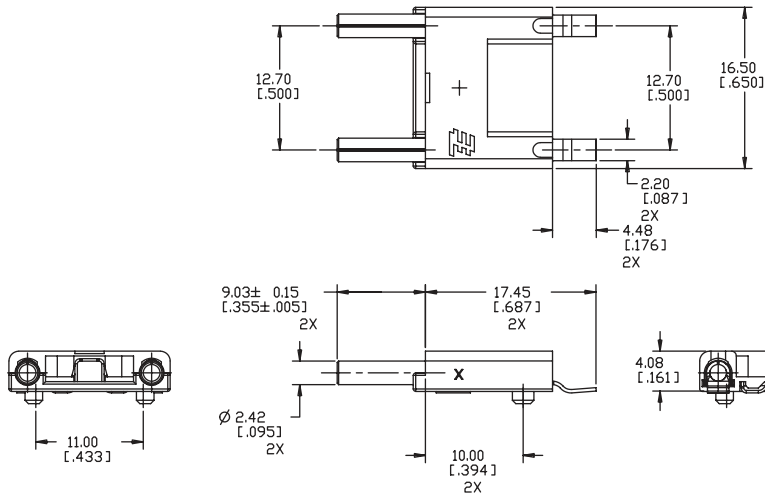

Recommended PC Board Layout

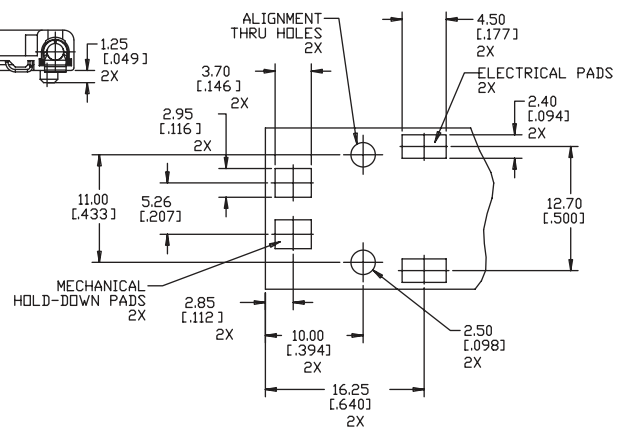

PIN 2106646-1

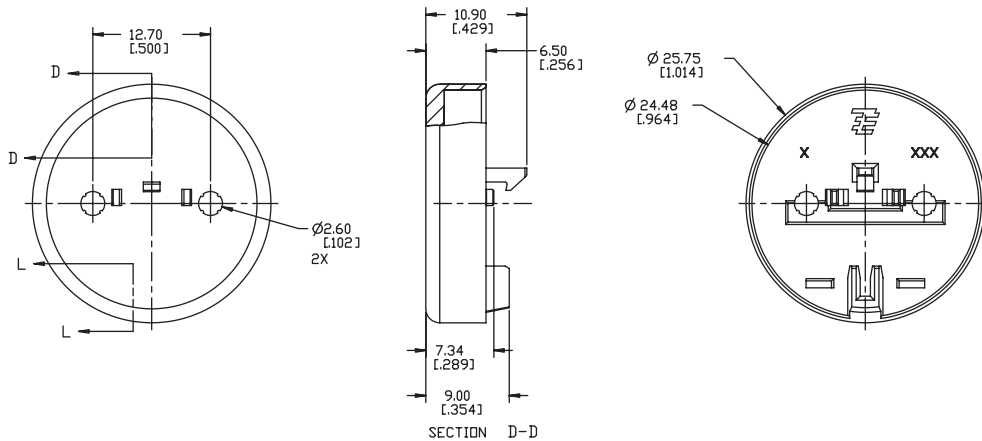

FOR MORE INFORMATION

www.tycoelectronics.com/lighting

Technical Support

Internet:	www.tycoelectronics.com/help
USA:	+1 (800) 522-6752
Canada:	+1 (905) 470-4425
Mexico & Central America:	+ 52(0) 55-1106-0814
South America:	+55 (0) 11-2103-6000
Germany:	+49 (0) 6251-133-1999
UK:	+ 44 (0) 8706-080208
France:	+33 (0) 1-3420-8686
Netherlands:	+31 (0) 73-6246-999
China:	+86 (0) 400-820-6015

Part numbers in this brochure are RoHS Compliant*, unless marked otherwise.

*as defined www.tycoelectronics.com/leadfree

Tyco Electronics Corporation

Harrisburg, PA

tycoelectronics.com

©2009 Tyco Electronics Corporation All Rights Reserved.

5-1773455-0 3M CGX 12/2009

TE (logo) and Tyco Electronics are trademarks of the Tyco Electronics group of companies and its licensors.

Other products, logos, and Company names mentioned herein may be trademarks of their respective owners.

While Tyco Electronics has made every reasonable effort to ensure the accuracy of the information in this catalog, Tyco Electronics does not guarantee that it is error-free, nor does Tyco Electronics make any other representation, warranty or guarantee that the information is accurate, correct, reliable or current. Tyco Electronics reserves the right to make any adjustments to the information contained herein at any time without notice. Tyco Electronics expressly disclaims all implied warranties regarding the information contained herein, including, but not limited to, any implied warranties of merchantability or fitness for a particular purpose. The dimensions in this catalog are for reference purposes only and are subject to change without notice. Specifications are subject to change without notice. Consult Tyco Electronics for the latest dimensions and design specifications.



Tyco Electronics
Our commitment. Your advantage.