

TOSHIBA Bi-CD Integrated Circuit Silicon Monolithic

TB67B001BFTG

Sensorless PWM Driver for 3-Phase Brushless Motors

The TB67B001BFTG (Later omitted TB67B001B), is a three-phase PWM chopper driver for sensorless brushless motors. It controls motor rotation speed by changing the PWM duty cycle, based on the speed control input.

TB67B001B: Normal state: High, Abnormal state: Low

Features

- Sensorless drive in three-phase full-wave
- PWM chopper control
- Control based on the PWM duty cycle input or analog voltage input is selectable
- Output current: Absolute maximum rating: 3 A
- Power supply: Absolute maximum rating: 25 V
- Adjustable output PMW duty cycle
- Selectable lead angle control function
- Selectable overlapping commutation (120°, 135°, and 150°)
- Selectable soft switching
- Rotation speed detecting signal (FG_OUT)
- Lock detecting signal (LD_OUT)

TB67B001B: Normal state: High, Abnormal state: Low

- Adjustable startup settings
- Selectable forced commutation frequency control function
- Selectable PWM frequency
- Restart function
- Overcurrent protection circuit (ISD)
- Thermal shutdown circuit (TSD)
- Under voltage lockout circuit (UVLO)
- Current limiter circuit

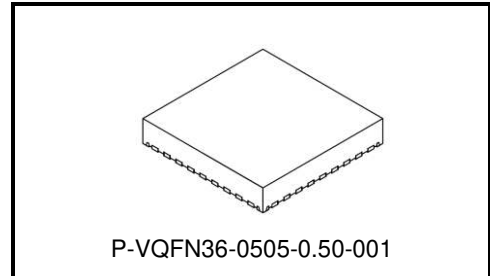

Weight: 0.05 g (typ.)

Start of commercial production
2022-10

Pin Assignment

<Top View>

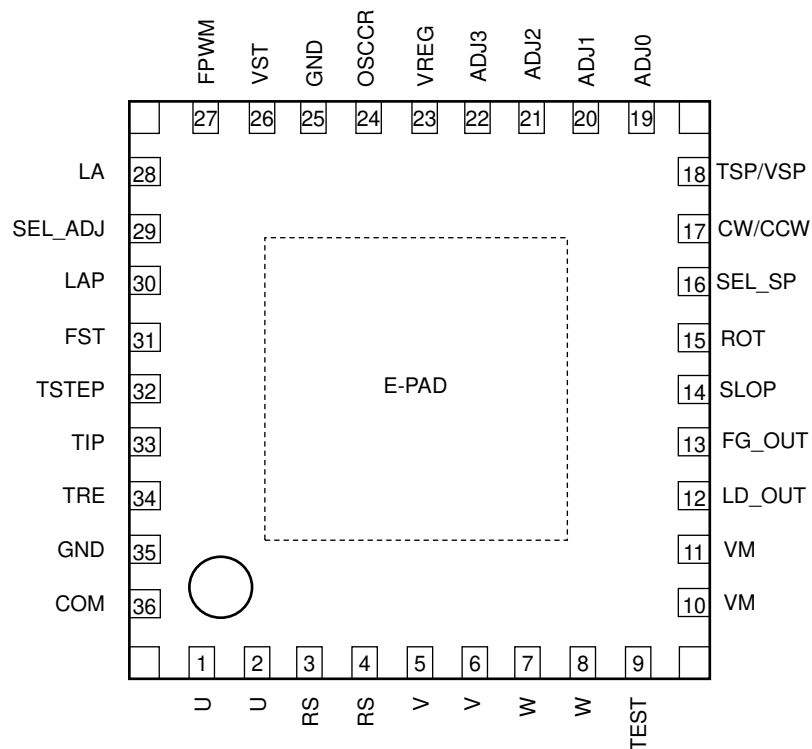

Note 1: Design the pattern in consideration of the heat design because a metal on the back side of a package E-PAD (3.4 mm × 3.4 mm) and the four corner PADS of a package have the role of heat radiation.

(A metal on the back side of a package (E-PAD) and the four corner PADS of a package are connected each other. And they should be connected to GND because they are connected to the back of the chip electrically.)

Note 2: Because each U, V, W, RS, and VM signal has two pins, short out these two pins at the external pattern respectively.

Pin Description

Pin No.	Symbol	I/O	Description
1	U	O	U-phase output pin
2	U	O	U-phase output pin
3	RS	—	Connection pin for output current detecting resistance
4	RS	—	Connection pin for output current detecting resistance
5	V	O	V-phase output pin
6	V	O	V-phase output pin
7	W	O	W-phase output pin
8	W	O	W-phase output pin
9	TEST	—	Test pin (Connect to ground)
10	VM	—	Motor power supply pin
11	VM	—	Motor power supply pin
12	LD_OUT	O	Lock detecting signal output pin (open-drain)
13	FG_OUT	O	Rotation speed detecting signal output pin (open-drain)
14	SLOP	I	Soft switching select input pin
15	ROT	I	Rotation speed of lead angle switching select input pin
16	SEL_SP	I	Control signal to TSP/VSP pin select input pin
17	CW/CCW	I	Forward/Reverse rotation direction select input pin
18	TSP/VSP	I	Speed command input pin (PWM duty cycle control or analog voltage control) in sensorless drive mode
19	ADJ0	I	Adjusting pin for characteristics of speed command input
20	ADJ1	I	Adjusting pin 1 for characteristics of output PWM duty cycle
21	ADJ2	I	Adjusting pin 2 for characteristics of output PWM duty cycle
22	ADJ3	I	Adjusting pin 3 for characteristics of output PWM duty cycle
23	VREG	—	Reference voltage output
24	OSCCR	—	Internal OSC setting pin
25	GND	—	Ground connection pin
26	VST	I	Output PWM duty cycle setting pin in DC excitation and forced commutation modes
27	FPWM	I	Output PWM frequency select input pin
28	LA	I	Lead angle setting input pin
29	SEL_ADJ	I	Output PWM duty cycle function setting input pin
30	LAP	I	Overlapping commutation select pin
31	FST	I	Forced commutation frequency select input pin
32	TSTEP	—	Connection pin for a capacitor to set the Output PWM duty cycle increasing time
33	TIP	—	Connection pin for a capacitor to set the DC excitation time
34	TRE	—	Connection pin for a capacitor to set the restart time
35	GND	—	Ground connection pin
36	COM	I	Connection pin for the center tap of the motor

Functional Description

In this chapter, the equivalent circuit diagrams may be simplified or some parts of them may be omitted for explanatory purposes. Timing charts may be simplified for explanatory purposes.

1. Sensorless Drive mode

Based on a command for a startup operation, the position of the rotor is fixed in DC excitation mode.

Then, the forced commutation signal is generated to start the motor rotation. As the motor rotates, the induced voltage occurs in each phase of the coil.

When a signal indicating the polarity of each phase voltage which includes the induced voltage is detected as a position signal, the motor driving signal is automatically switched from the forced commutation signal to the normal commutation signal that is based on the position signal (induced voltage). Then, a brushless motor starts running in sensorless commutation mode.

1.1 Forward /Reverse rotation direction select input pin: CW/CCW pin

When CW/CCW pin = Low, a motor rotates in forward direction. When CW/CCW pin = High, a motor rotates in reverse direction.

Switch the rotation direction after a motor is stopped to avoid stepping out.

- CW/CCW pin = Low (Forward)

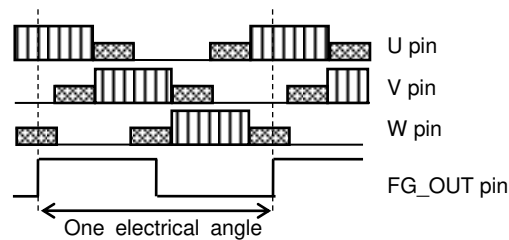

- CW/CCW pin = High (Reverse)

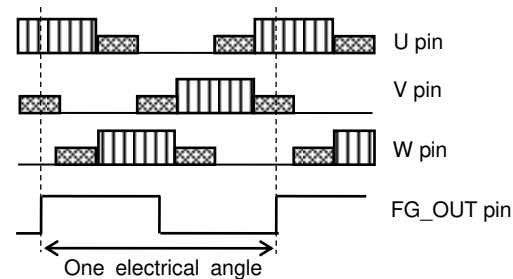

1.2 Rotation speed detection signal output pin: FG_OUT pin

A two-pole motor outputs a signal of 1 ppr (1 pulse/electrical angle) according to the induced voltage.

A four-pole motor outputs signal of 2 ppr similarly.

2. Startup Operation

At startup, no induced voltage is generated due to the stationary motor, and the rotor position cannot be detected for sensorless drive.

Therefore, first, this IC fixes a rotor position of motor in DC excitation mode for an appropriate period of time. And then it has a motor make starting up in forced commutation mode.

The DC excitation time is determined by the TIP pin.

The forced commutation frequency is determined by the FST pin.

The output PWM duty cycles in DC excitation and forced commutation modes are determined by the voltage of VST pin.

For sensorless drive mode, the output PWM duty cycle is determined by the speed command input to TSP/VSP pin to start and stop the motor operation, and to control the motor speed.

Since the time and startup torques (output PWM duty cycle) in DC excitation and forced commutation vary depending on the motor type and load, they should be adjusted experimentally.

2.1 DC Excitation Mode

The DC excitation time is determined by the value of capacitor (C2) connected to the TIP pin.

$$\text{DC excitation time: Tip (s)} = 0.25 \times 31.5 \text{ times} \times C2 \text{ (F)} \times 10^6$$

When C2 = 0.01 μF, Tip = 0.0986 s

2.2 Forced Commutation Mode

The forced commutation frequency is determined by the voltage of the FST pin.

FST = High: Forced commutation frequency $f_{ST} \approx 8.0\text{Hz}$

FST = Middle or Open: Forced commutation frequency $f_{ST} \approx 4.0\text{ Hz}$

FST = Low: Forced commutation frequency $f_{ST} \approx 2.0\text{ Hz}$

(Note: ROsc=16kΩ)

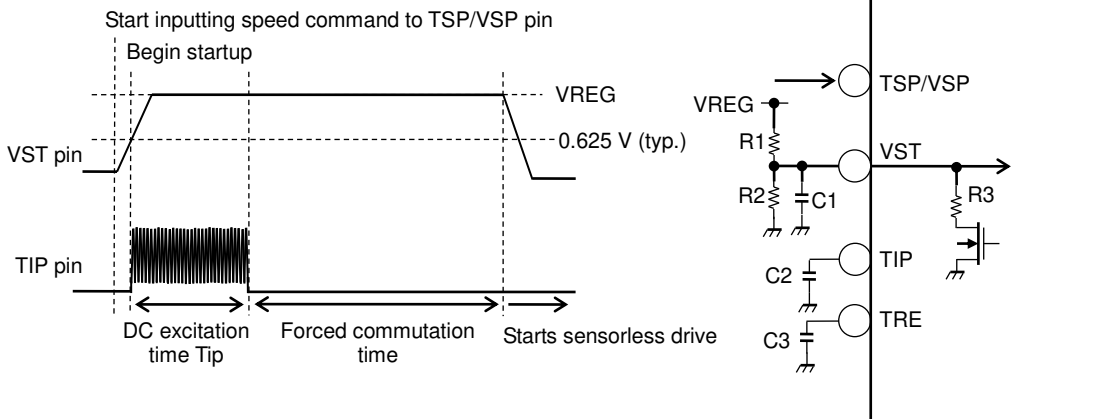

2.3 Timing Chart of the Startup Operation

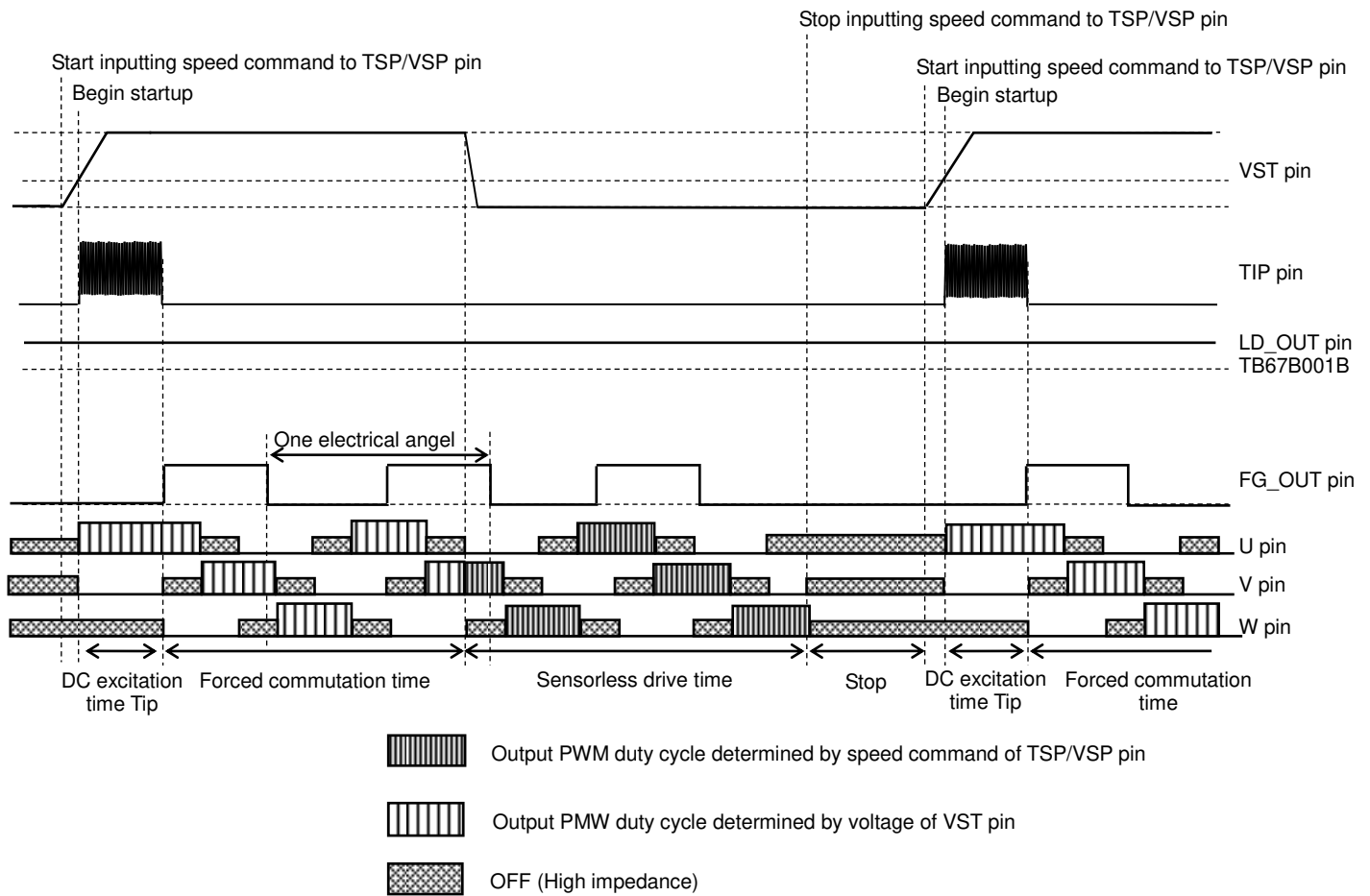

3. Operation in Abnormality Detection

When the following events are detected, the operation in abnormality detection is done.

1. The forced commutation frequency exceeds four electrical-degree period.
2. The overcurrent protection circuit (ISD) is activated.
3. The thermal shutdown circuit (TSD) is activated.
4. The rotation frequency in sensorless drive mode is the forced commutation frequency or less.
5. The rotation frequency (commutation frequency) is the maximum rotation frequency (FMAX) or more.

FMAX depend on the state of FST pin is shown below.

FST pin = High:	FMAX = 1.875 kHz / 1 electrical angle frequency
FST pin = Middle or open:	FMAX = 1.875 kHz / 1 electrical angle frequency
FST pin = Low:	FMAX = 937.5 Hz / 1 electrical angle frequency

Note: ROsc=16kΩ

When any abnormality is detected, output pins are turned off (high impedance) during the operation restart time (Tre).

The restart time is determined by the value of a capacitor (C3) connected to TRE pin.

$$\text{Restart time: } T_{re} \text{ (s)} = 0.25 \times 31.5 \text{ times} \times C3 \text{ (F)} \times 10^6$$

When C3 = 1 μF, Tre = 9.86 s.

3.1 Timing Chart of Abnormality Detection

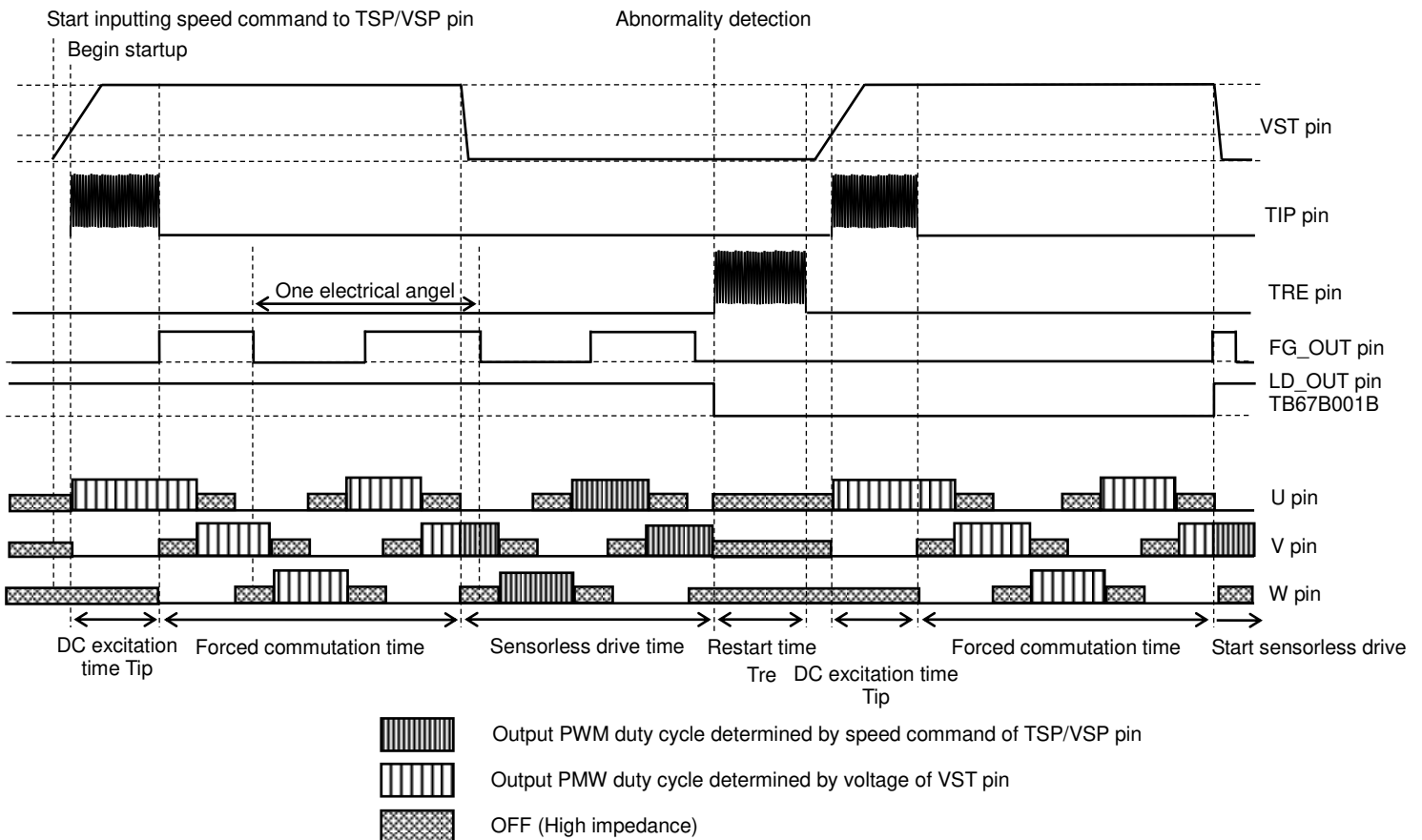

3.2 Operation in Lock Detection

When the operation mode does not change from the forced commutation mode to the senseless drive mode by the motor rotation lock and so on, the LD_OUT pin outputs low from starting the restart.

Then, the following operations are repeated and the LD_OUT pin keeps low until the sensorless drive mode starts normally.

Restart time → DC excitation time → forced commutation time (during 4-electrical angles) → Restart time → DC excitation time...

When the inputting speed command to TSP/VSP pin is stopped in the lock detection, the LD_OUT pin keeps low until the sensorless drive mode starts.

3.3 Timing Chart of Lock Detection

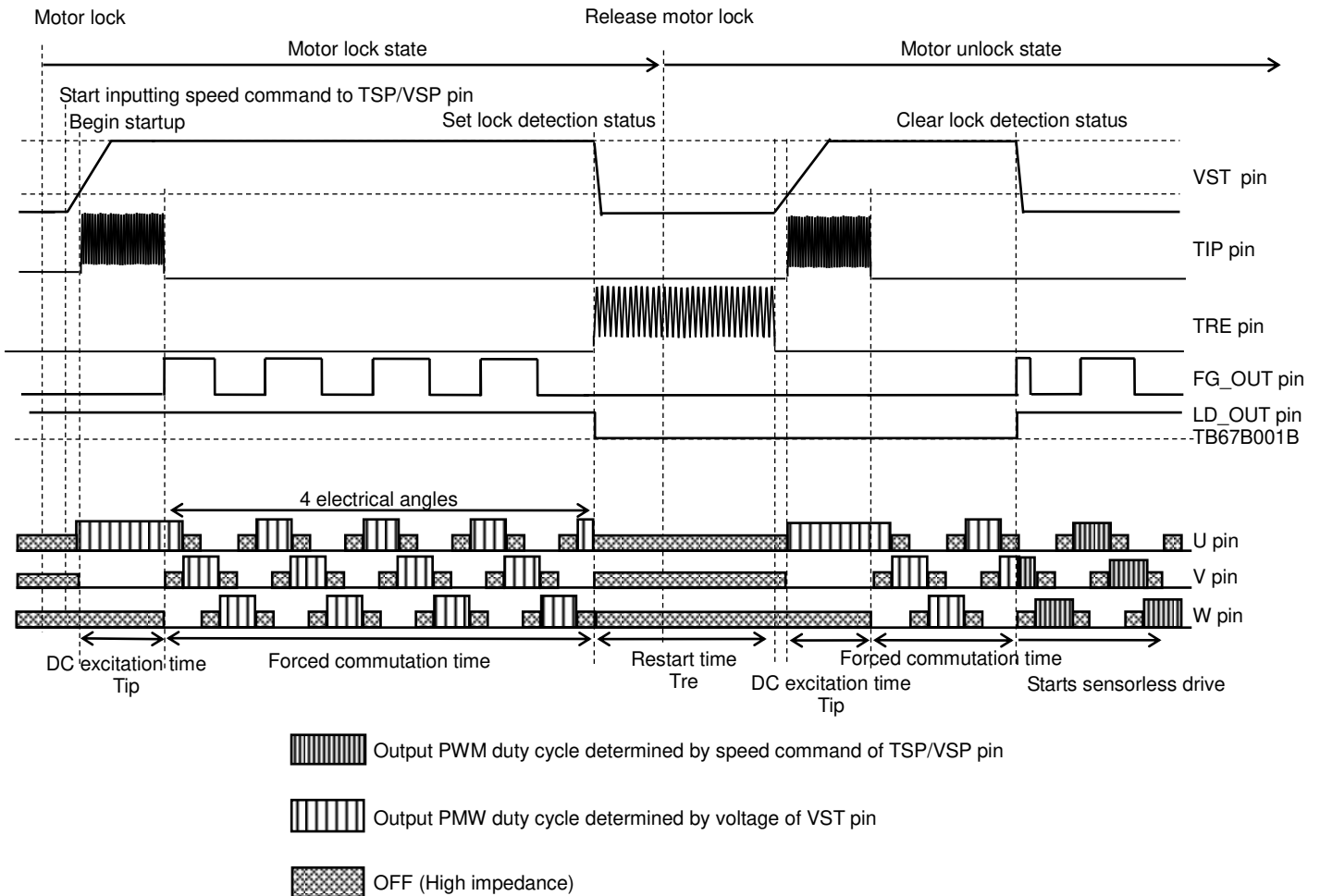

3.4 Timing Chart of Stopping Speed Command of TSP/VSP pin during Lock Detection

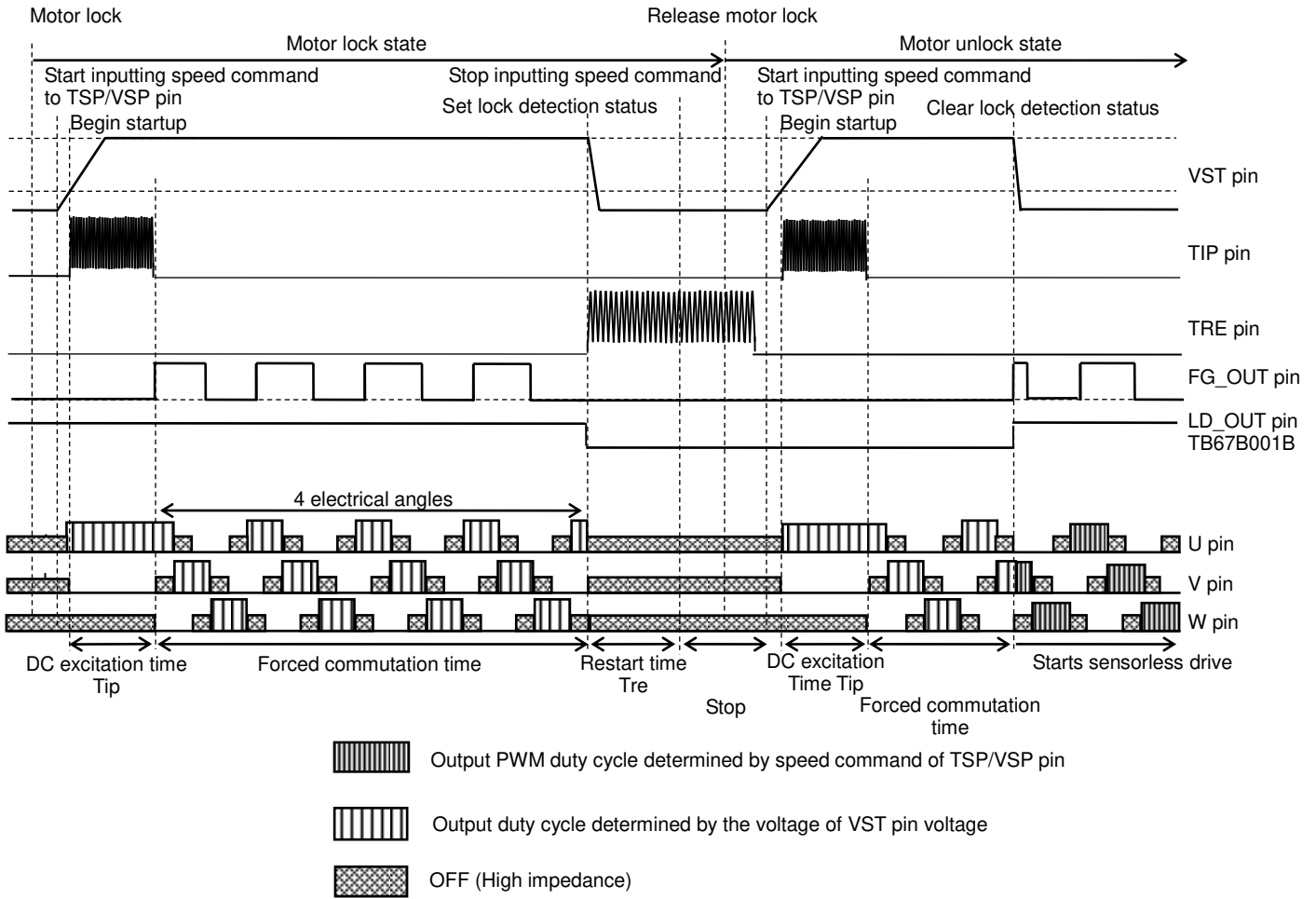

4. PWM frequency

Output PWM frequency determined by the input voltage of FPWM pin.

Depending on the set value, the PWM frequency changes according to the rotation speed.

The PWM frequency must be sufficiently high relative to the electrical frequency of the motor and within the range permitted by the switching characteristics of the driver circuit.

Setting steps	FPWM pin voltage (V)	Rotation speed (Electrical angle)					
		0 Hz to less than 250 Hz	250 Hz to less than 500 Hz	500 Hz to less than 750 Hz	750 Hz to less than 1 kHz	1 kHz to less than 1.25 kHz	1.25 kHz to 1.875 kHz
8	2.5	29.75 kHz	59.625 kHz	119.125 kHz	119.125 kHz	238.25 kHz	238.25 kHz
7	2.1875	29.75 kHz	29.75 kHz	59.625 kHz	59.625 kHz	119.125 kHz	119.125 kHz
6	1.875	29.75 kHz	59.625 kHz	119.125 kHz	119.125 kHz	119.125 kHz	119.125 kHz
5	1.5625	59.625 kHz	59.625 kHz	119.125 kHz	119.125 kHz	119.125 kHz	238.25 kHz
4	1.25	59.625 kHz	119.125 kHz	119.125 kHz	119.125 kHz	119.125 kHz	238.25 kHz
3	0.9375	238.25 kHz					
2	0.625	119.125 kHz					
1	0.3125	59.625 kHz					
0	0	29.75 kHz					

Note: ROSC=16kΩ

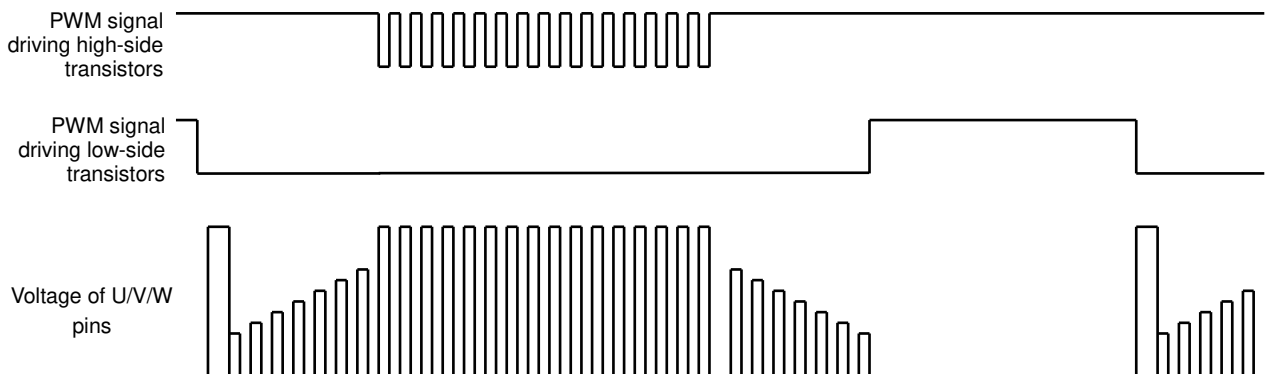
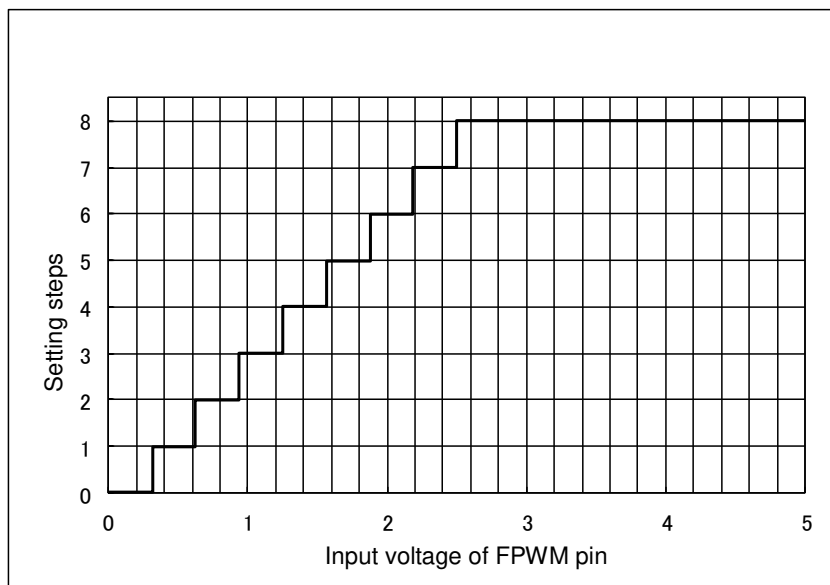

5. Motor Speed Control

Control signal to TSP/VSP pin can make on/off the motor and control the output PWM duty cycle to control the rotation speed of the motor.

It can also select the analog voltage control or the PWM duty cycle control by the level of SEL_SP pin.

As other functions, the control signal to TSP/VSP pin can adjust the variation of the output PWM duty cycle by the voltage level of ADJ0 pin, ADJ1 pin, ADJ2 pin, and ADJ3 pin.

Level of SEL_SP pin	Control signal to TSP/VSP pin
High	An analog voltage
Low	A PWM duty cycle

5.1 Relation between the Voltage of a VST Pin and Output PWM Duty Cycle in DC Excitation and the Forced Commutation Modes.

Output PWM duty cycle in the DC excitation and the forced commutation modes are determined by the voltage of VST pin.

$0 \leq \text{Voltage of VST pin} \leq V_{AD(L)}: 0.625 \text{ V (typ.)}$

→ Output PWM duty cycle = 0%

$V_{AD(L)} \leq \text{Voltage of VST pin} \leq V_{AD(H)}: 3.125 \text{ V (typ.)}$

→ Output PWM duty cycle = 0% to 100% (0/128 to 128/128)

$V_{AD(H)} \leq \text{Voltage of VST pin} \leq V_{REG}$

→ Output PWM duty cycle = 100% (128/128)

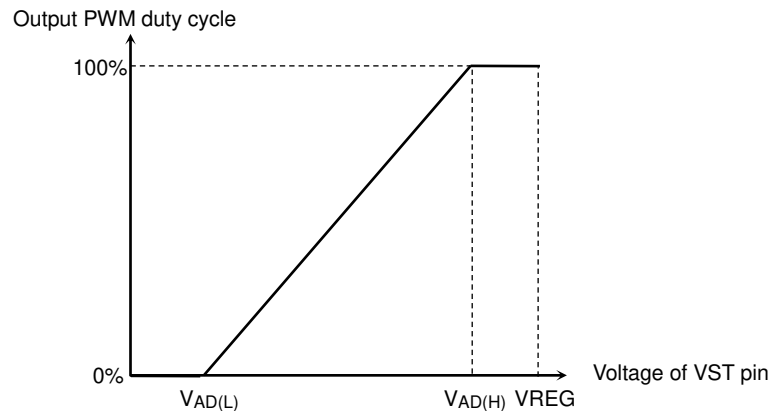

5.2 Relation between a Voltage of TSP/VSP Pin and Output PWM Duty Cycle in Sensorless Drive Mode (SEL_SP pin = High)

This section describes in case of the control signal is an analog voltage.

The startup operation begins when a voltage of TSP/VSP pin is 0.625 V (typ.) or above. And the startup operation is reset when it is less than 0.625 V.

$0 \leq$ Voltage of TSP/VSP pin $\leq V_{AD(L)}$: 0.625 V (typ.)

→ Output PWM duty cycle = 0% (0/128)

$V_{AD(L)} \leq$ Voltage of TSP/VSP pin $\leq V_{AD(H)}$: 3.125 V (typ.)

→ Output PWM duty cycle = 0% to 100% (0/128 to 128/128)

$V_{AD(H)} \leq$ Voltage of TSP/VSP pin $\leq V_{REG}$

→ Output PWM duty cycle = 100% (128/128)

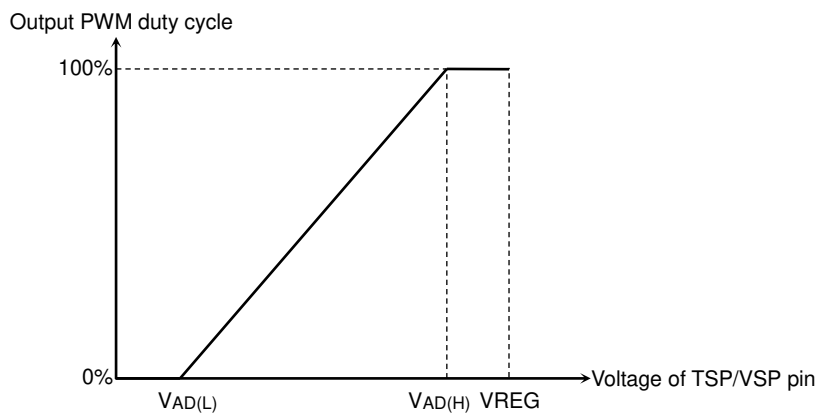

Note: The relation when ADJ1 pin, ADJ2 pin, and ADJ3 pin are connect to ground is shown above. For details of ADJ1 pin, ADJ2 pin and ADJ3 pin, refer to 5.4.

5.3 Relation between PWM Duty Cycle of TSP/VSP Pin and Output PWM Duty Cycle in Sensorless Drive Mode (SEL_SP pin = Low)

This section describes in case of the control signal is the PWM duty cycle.

The startup operation begins when the PWM signal is inputted to TSP/VSP pin.

The ON time of the PWM signal may be not detected when it is 0.16 μ s or less. Also, the PWM signal is decided as no signal when the OFF time of the PWM signal is 2.0 ms or above.

The frequency of the PWM signal to TSP/VSP pin should be in the range from 500 Hz to 125 kHz.

In changing Duty, it should be changed within 408 ms because Duty is kept for 408 ms. When it exceeds 408 ms, the operation is judged stop. When signal of stop is inputted, the operation stops after 408 ms passes because Duty is kept for 408 ms.

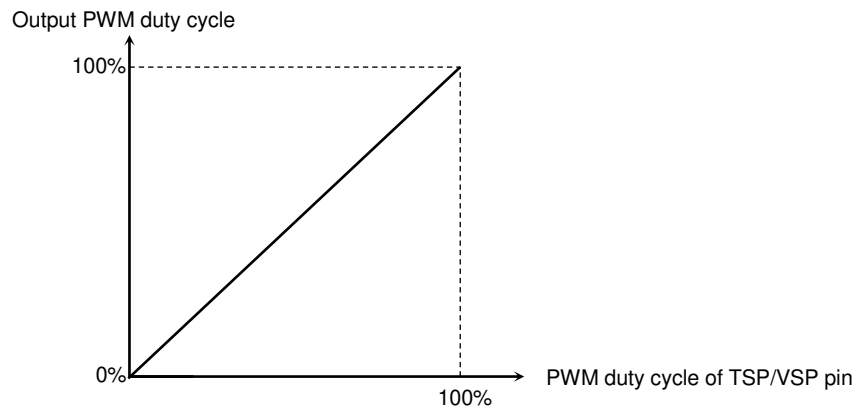

Note: The relation when ADJ1 pin, ADJ2 pin, and ADJ3 pin are connect to ground is shown above. For details of ADJ1 pin, ADJ2 pin and ADJ3 pin, refer to 5.4.

Note: ROsc=16k Ω

5.4 Adjustment of the Relation between the Control Signal to TSP/VSP Pin and Output PWM Duty Cycle

Three points of output PWM duty cycles can be adjusted by the voltages of ADJ1 pin, ADJ2 pin and ADJ3 pin.

Voltage input pin for adjustment	Adjusted output PWM duty cycle
ADJ1 pin	DOUT1
ADJ2 pin	DOUT2
ADJ3 pin	DOUT3

The DOUT2 is the output PWM duty when the percent value of the control signal of TSP/VSP pin is 50% (typ.). And also, the DOUT3 is the output PWM duty when the percent value of the control signal of TSP/VSP pin is 90% (typ.).

The DOUT1's percent of the control signal can be adjusted by the voltage of ADJ0

Percent value of the control signal of TSP/VSP pin	Output PWM duty cycle
Value specified by the voltage of ADJ0 pin (DIN1)	DOUT1
50% (typ.) (DIN2)	DOUT2
90% (typ.) (DIN3)	DOUT3

- 1) Relation between the voltages of ADJ1, ADJ2 and ADJ3 pins and the output PWM duty cycles (DOUT1, DOUT2, DOUT3)

$0 \leq$ Voltages of ADJ1, ADJ2 and ADJ3 pins $\leq V_{AD(L)}$: 0.625 V (typ.)

→ The output PWM duty cycle (DOUT1, DOUT2, DOUT3) = 0% (0/128)

$V_{AD(L)} \leq$ Voltages of ADJ1, ADJ2 and ADJ3 pins $\leq V_{AD(H)}$: 3.125 V (typ.)

→ The output PWM duty cycle (DOUT1, DOUT2, DOUT3) = 0% to 100% (0/128 to 128/128)

$V_{AD(H)} \leq$ Voltages of ADJ1, ADJ2 and ADJ3 pins $\leq V_{REG}$

→ The output PWM duty cycle (DOUT1, DOUT2, DOUT3) = 100% (128/128)

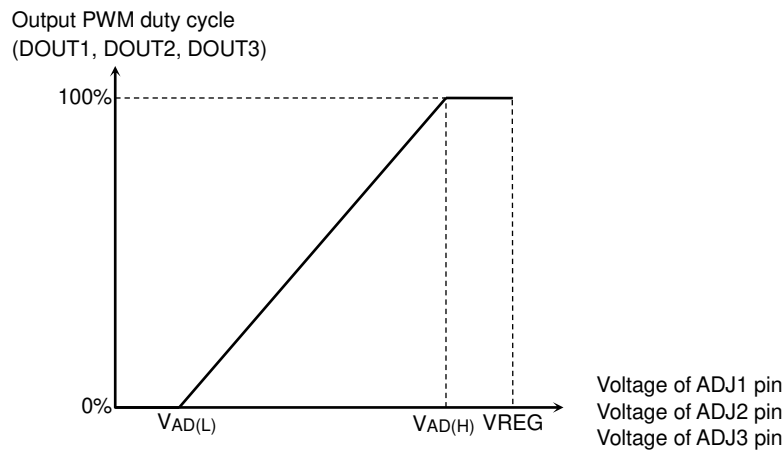

Note: Voltage setting of ADJ1 pin, ADJ2 pin and ADJ3 pin should be set as follows; voltage of ADJ1 pin \leq voltage of ADJ2 pin \leq voltage of ADJ3 pin. If it is set as follows; voltage of ADJ1 pin $>$ voltage of ADJ2 pin $>$ voltage of ADJ3 pin, this function may not operate correctly.

- 2) Relation between a voltage of ADJ0 pin and the DIN1 which makes the output PWM duty cycle as the DOUT1 is shown below;

$0 \leq$ Voltages of ADJ0 pin $\leq V_{AD(L)}$: 0.625 V (typ.)
 → The percent of the control signal (DIN1) = 0% (0/128)
 $V_{AD(L)} \leq$ Voltages of ADJ0 pin $\leq V_{AD(H)}$: 3.125 V (typ.)
 → The percent of the control signal (DIN1) = 0% to 50% (0/128 to 128/128)
 $V_{AD(H)} \leq$ Voltages of ADJ0 pin $\leq V_{REG}$
 → The percent of the control signal (DIN1) = 50% (128/128)

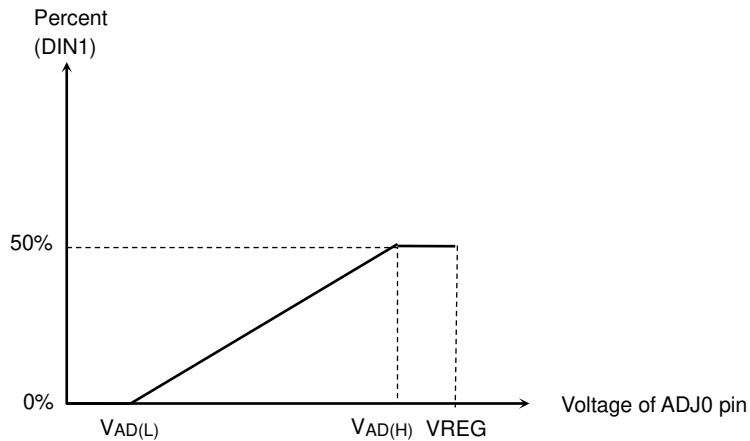

- 3) When the percent value of the control signal is equal or less than the duty cycle (DIN1) specified by a voltage of ADJ0 pin, the relation between the percent value of the control signal and output PWM duty cycle according to the state of SEL_ADJ pin is shown in the below table.

SEL_ADJ	Operation state
High	When the percent value of the control signal is DIN1 or less, the output PWM duty cycle is kept as DOUT1.
Middle	When the percent value of the control signal is DIN1 or less, the output PWM duty cycle changes in linier from the output PWM duty cycle of DIN1 to 0%.
Low	When the percent value of the control signal is DIN1 or less, the output PWM duty cycle is fixed to 0%.

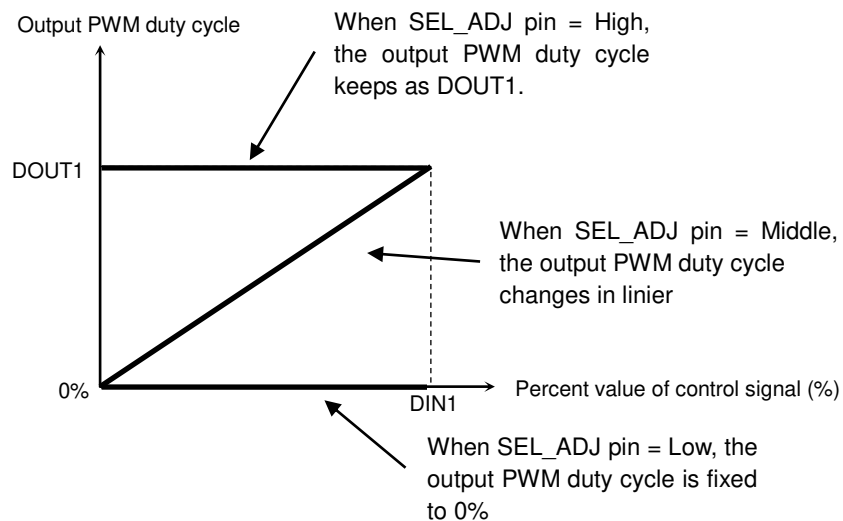

4) Setting example

Percent of control signal of TSP/VSP pin	Output PWM duty cycle
Up to 20%	From 0% to 30% in linier
20% (DIN1)	30% (DOUT1)
50% (typ.) (DIN2)	40% (DOUT2)
90% (typ.) (DIN3)	80% (DOUT3)

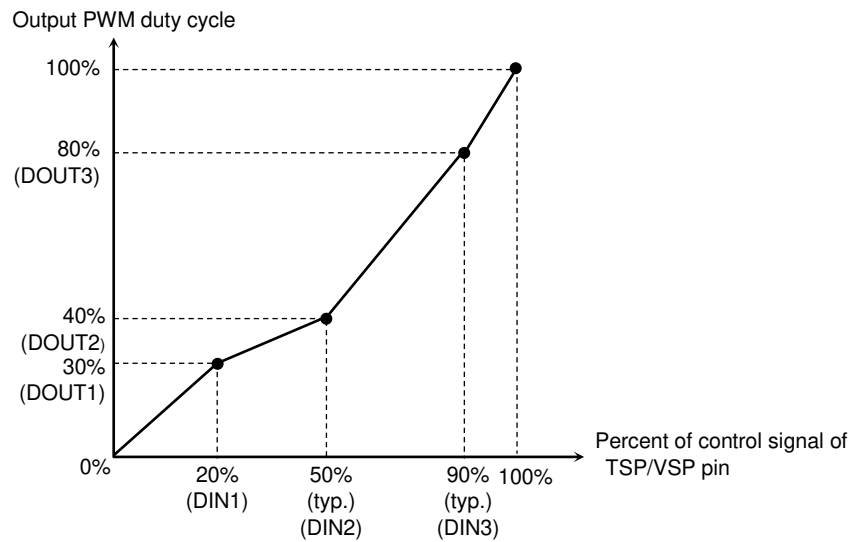

To set the above relation between the percent of control signal of TSP/VSP pin and the output PWM duty cycle, set the level of SEL_ADJ pin and the voltage of ADJ0 pin, ADJ1 pin, ADJ2 pin and ADJ3 pin shown below.

- SEL_ADJ pin = Middle
- Voltage of ADJ0 pin: $(20\% / 50\% \times (3.125 - 0.65V)) + 0.625V = 1.625V$
- Voltage of ADJ1 pin: $(30\% / 100\% \times (3.125 - 0.65V)) + 0.625V = 1.375V$
- Voltage of ADJ2 pin: $(40\% / 100\% \times (3.125 - 0.65V)) + 0.625V = 1.625V$
- Voltage of ADJ3 pin: $(80\% / 100\% \times (3.125 - 0.65V)) + 0.625V = 2.625V$

6. Commutation Control

In forced commutation mode at startup, this IC is configured for 120° commutation with a lead angle of 0°, and without soft switching.

Then, when the operation mode enters sensorless driving mode, its commutation waveform automatically changes to the one specified by the LA, the LAP, and the SLOP pins.

When SLOP pin is Low, the soft switching function operates. The output PWM duty cycle in output commutation switching changes in stages.

The soft switching pattern is three depend on the state of LAP pin. And the soft switching pattern of 150° commutation has the Pattern A and Pattern B. They have difference of the output duty cycle changes in stages.

When SLOP pin is High, the soft switching function does not operate.

SLOP pin	LAP pin	Soft switching	Commutation angle
High	High	N/A	120° commutation
	Middle	N/A	135° commutation
	Low	N/A	150° commutation
Low	High	Available (With pattern B)	150° commutation
	Middle	Available	135° commutation
	Low	Available (With pattern A)	150° commutation

6.1 Setting lead angle

When ROT pin is High, the lead angle is determined by the voltage of LA pin regardless of the rotation speed.
 When ROT pin is Low, the lead angle changes depending on the rotation speed.

At this time, in case of FST pin is Low, the lead angle changes whenever the rotation speed increases 125 Hz. In case of FST pin is Middle or High, the lead angle changes whenever it increases 250 Hz.

Note: When 135° commutation is selected, upper limit of the lead angle is 22.5°. And more than 22.5° cannot be configured. Likewise, when 150° commutation is selected, upper limit of the lead angle is 15° and more than 15° cannot be configured.

Note: ROSC=16kΩ

ROT pin	Steps of LA setting	Voltage of LA pin (V)	Rotation speed (electrical angle)					
			When FST pin is Low, upper (0 to 937.5 Hz) / When FST pin is High or Middle, lower (0 to 1.875 kHz)					
			0 Hz to less than 125 Hz	125 Hz to less than 250 Hz	250 Hz to less than 375 Hz	375 Hz to less than 500 Hz	500 Hz to less than 625 Hz	625Hz to 937.5Hz
High	8	2.5	30°					
	7	2.1875	26.25°					
	6	1.875	22.5°					
	5	1.5625	18.75°					
	4	1.25	15°					
	3	0.9375	11.25°					
	2	0.625	7.5°					
	1	0.3125	3.75°					
	0	0	0°					
Low	8	2.5	3.75°	11.25°	18.75°	26.25°	30°	30°
	7	2.1875	11.25°	15°	18.75°	22.5°	26.25°	30°
	6	1.875	7.5°	11.25°	15°	18.75°	22.5°	26.25°
	5	1.5625	3.75°	7.5°	11.25°	15°	18.75°	22.5°
	4	1.25	0°	3.75°	7.5°	11.25°	15°	18.75°
	3	0.9375	0°	15°	15°	15°	18.75°	22.5°
	2	0.625	7.5°	7.5°	15°	15°	18.75°	22.5°
	1	0.3125	0°	7.5°	15°	15°	18.75°	22.5°
	0	0	7.5°	15°	15°	15°	18.75°	22.5°

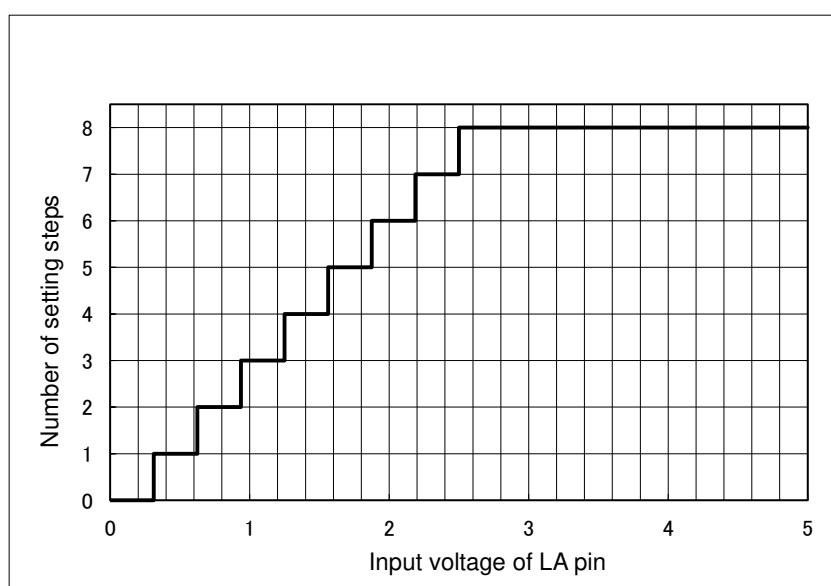

6.2 Waveform of commutation timing (CW/CCW pin = Low)

- SLOP pin = High, LAP pin = High (120° commutation)

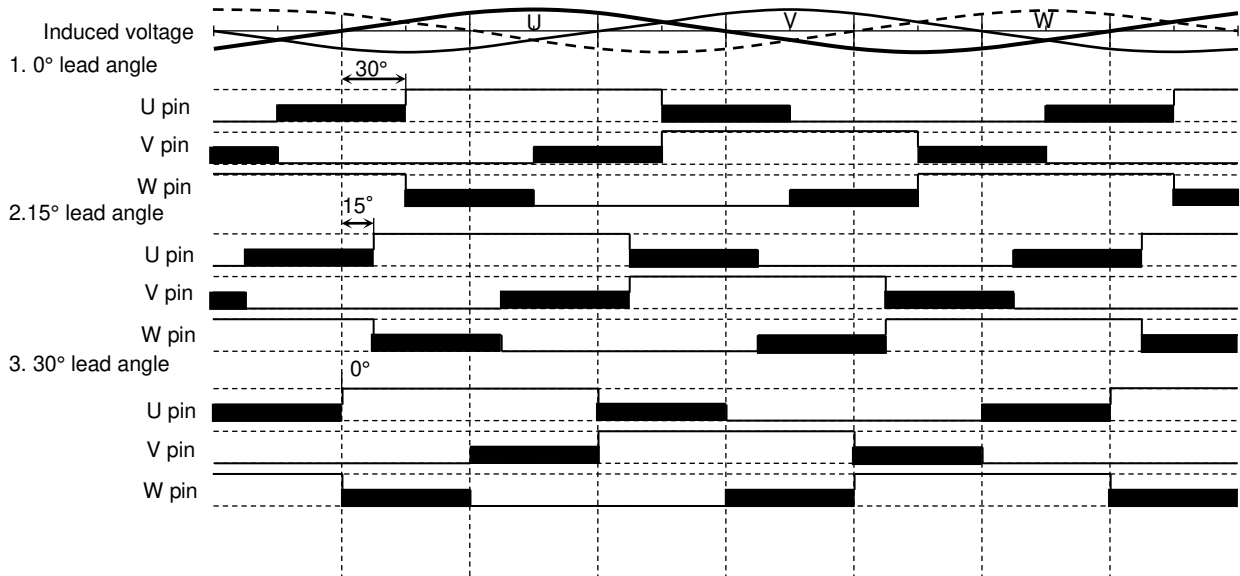

- SLOP pin = High, LAP pin = Middle (135° commutation)

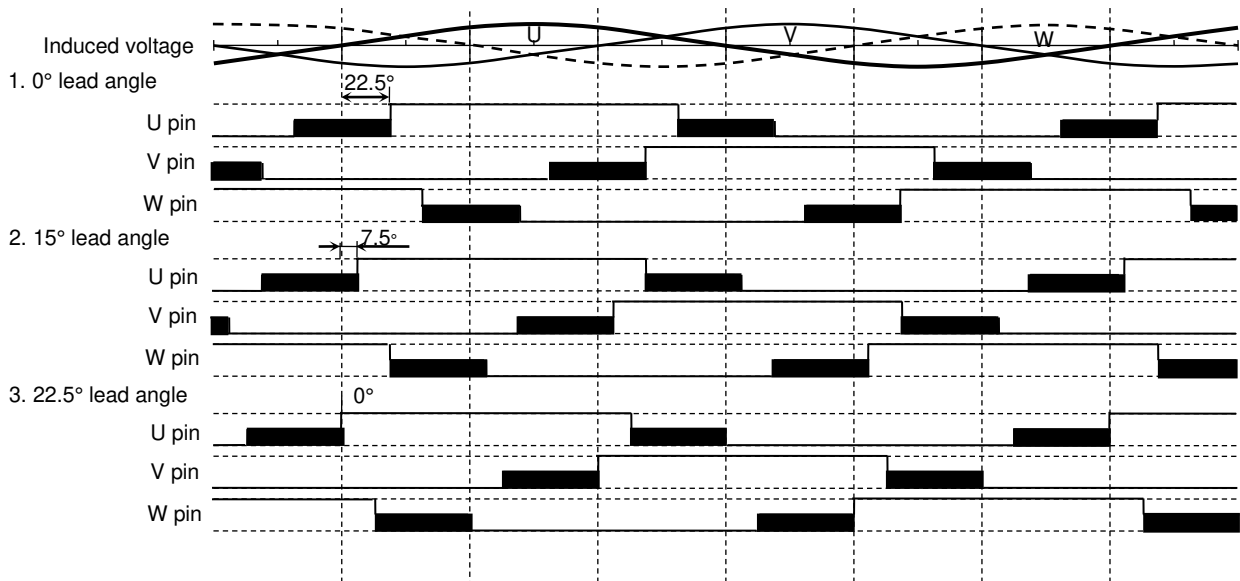

■ OFF (High impedance) time

- SLOP pin = High, LAP pin = Low (150° commutation)

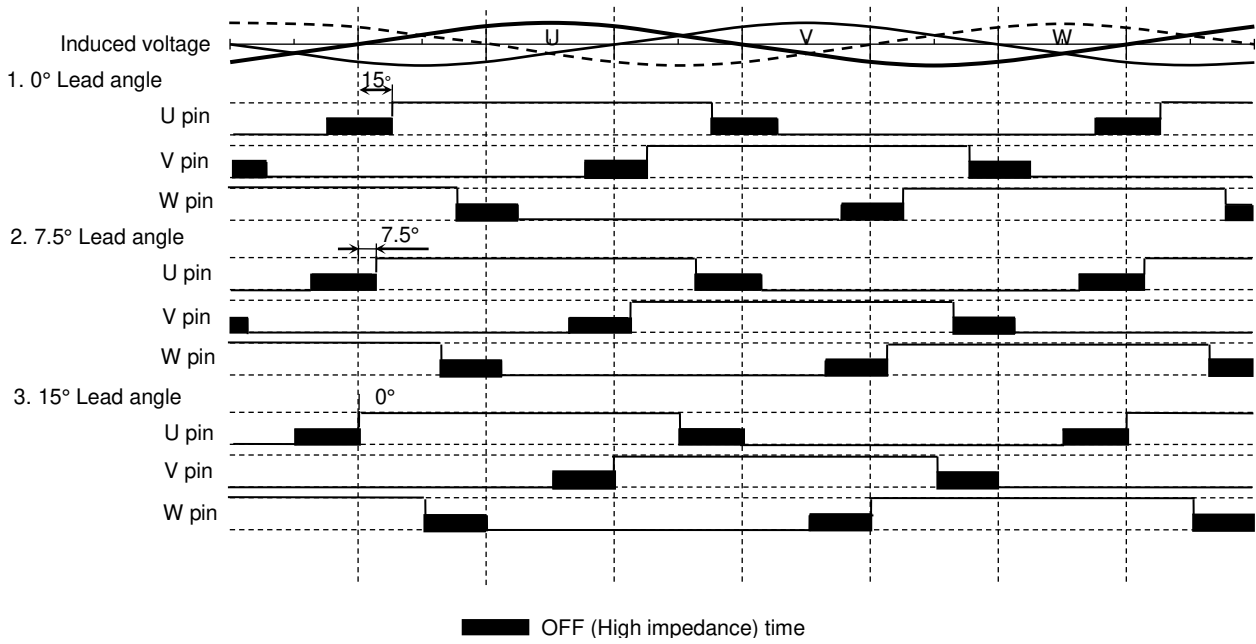

- SLOP pin = Low, LAP pin = Middle (135° commutation, 0° Lead angle)

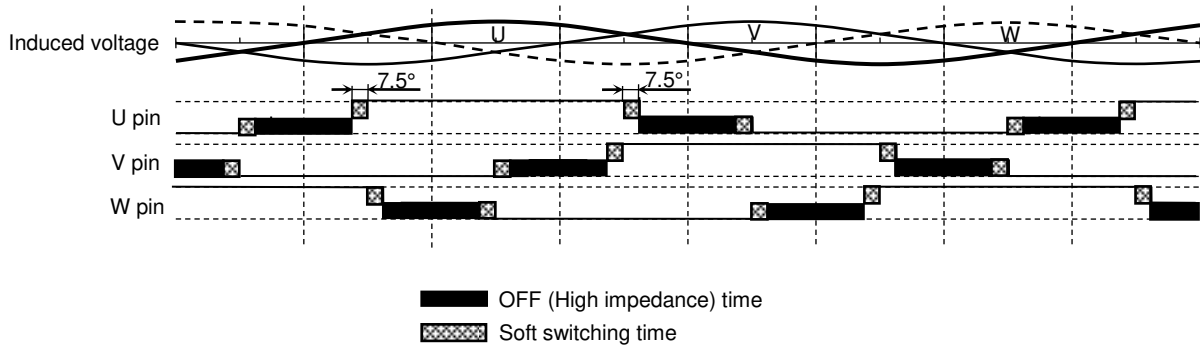

- SLOP pin = Low, LAP pin = High or Low (150° commutation, 0° Lead angle)

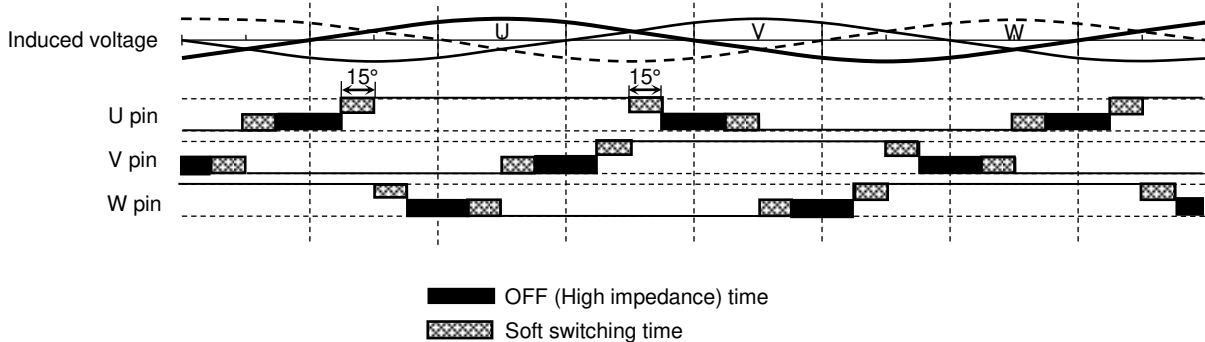

7. Current Limiter Circuit

The current limiter circuit limits the current by turning the high-side transistors off. These transistors are turned back on again when the PWM signal is turned on.

The output current is monitored as a voltage across R1 by a comparator. If it exceeds the rated V_{RS} voltage (0.25 V typ.), the current limiter is activated.

A masking time of current limit detection (T_{RS}) of 2.4 μs (typ.) (ROSC=16kΩ) is provided to avoid an incorrect operation by an external noise, etc.

Example: When R1 is 0.3 Ω, the current I_{OUT} which activates the current limiter circuit is shown as below;

$$I_{OUT} = 0.25 \text{ V (typ.)} \div 0.3 \Omega \approx 0.83 \text{ A}$$

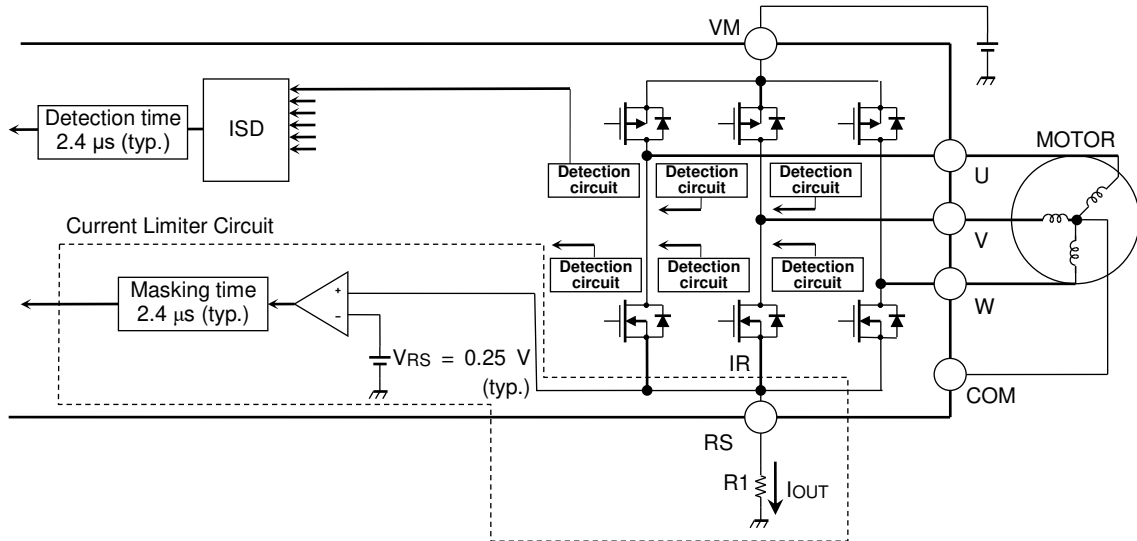

<Current Limiter Circuit Operation>

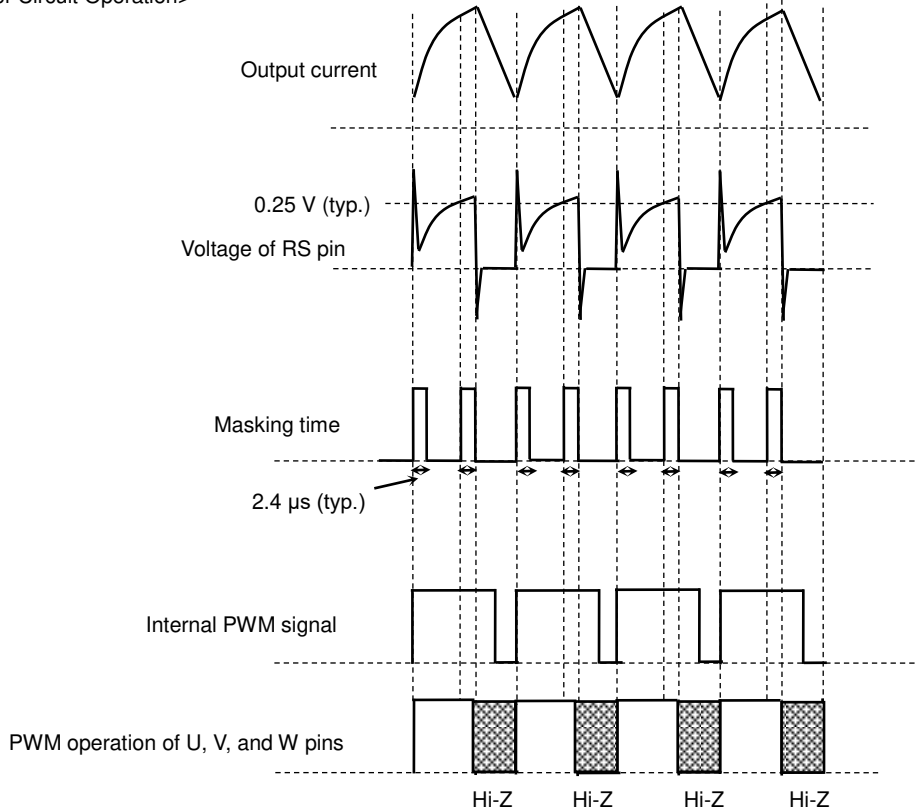

Hi-Z: High impedance

8. Overcurrent Protection Circuit (ISD)

This IC incorporates the detection circuit for each six output transistors that monitors the current flowing. The six output of detection circuit are inputted to overcurrent protection circuit (ISD). The threshold current of overcurrent protection circuit is from 3 A to 6 A.

And if the current at any one of six transistors is the equal or more than the threshold current for 2.4 μs (Masking time of overcurrent protection circuit: T_{ISD}) (typ.) or longer, ISD makes all output transistors turning off (high impedance). (ROSC=16kΩ)

If the current at all transistors is less than the threshold current, this IC begins startup operation after the restart time (T_{re}) that is specified by the value of a capacitor connected to TRE pin has elapsed.

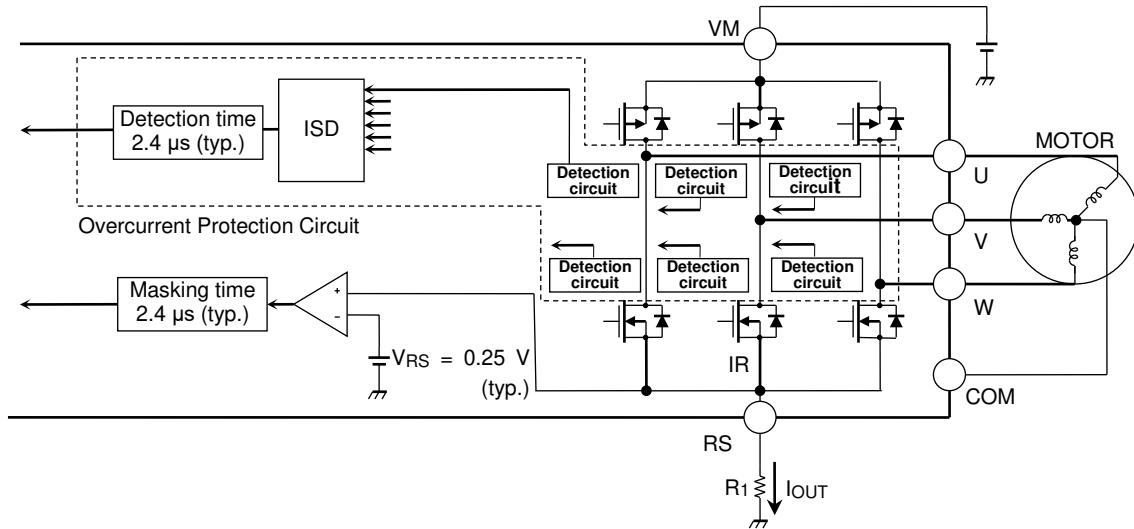

<ISD operation>

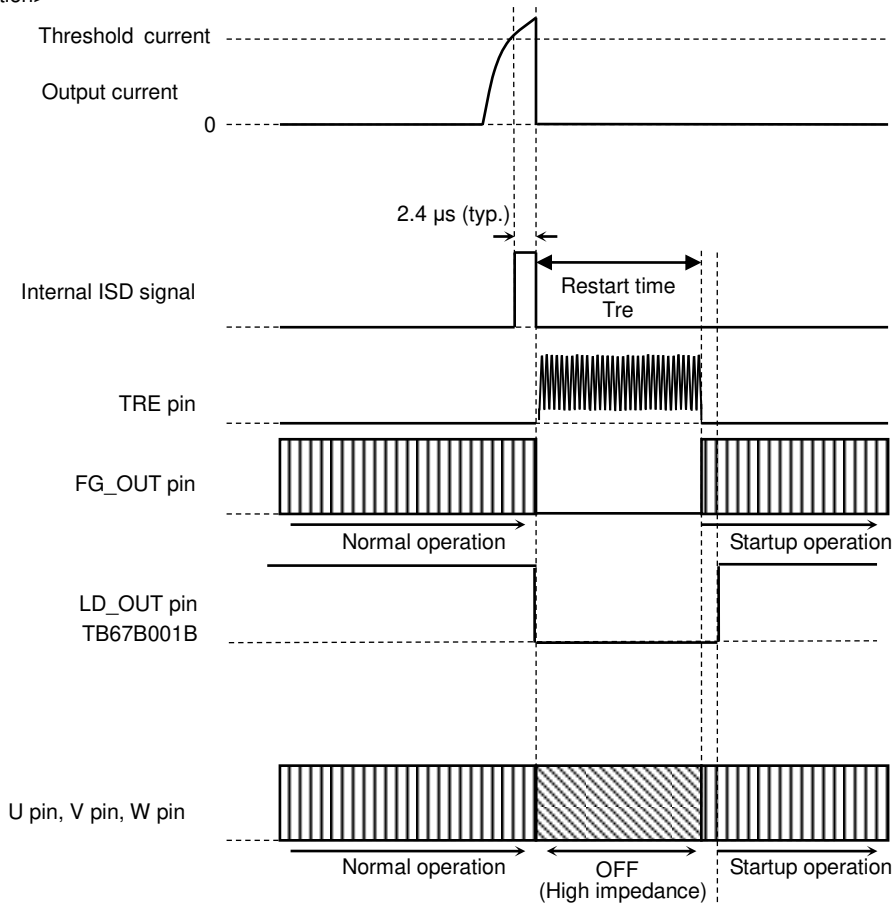

Note: When the ISD circuit is activated, the output current is more than the absolute maximum current rating. This circuit is provided as an auxiliary only and does not necessarily provide the IC with a perfect protection from damages due to overcurrent caused by power fault, ground fault, load-short and the like.

9. PWM duty cycle increasing time Control Circuit

When the value of the control signal to TSP/VSP pin is increasing, the time which is from changing the control signal to changing the output PWM duty cycle can be specified.

By the PWM duty increasing time control circuit, the output PWM duty cycle can be gradually increased in a startup operation.

The output PWM duty cycle increasing time is specified by a value of a capacitor (C) connected to TSTEP pin.

Example: PWM duty cycle increasing time: $T_{soft} (s) = 0.25 \times 31.5 \text{ times} \times C (F) \times 10^6$
 When C is 0.01 μF , T_{soft} is 0.0986 s.

- When the control signal increases of 13%

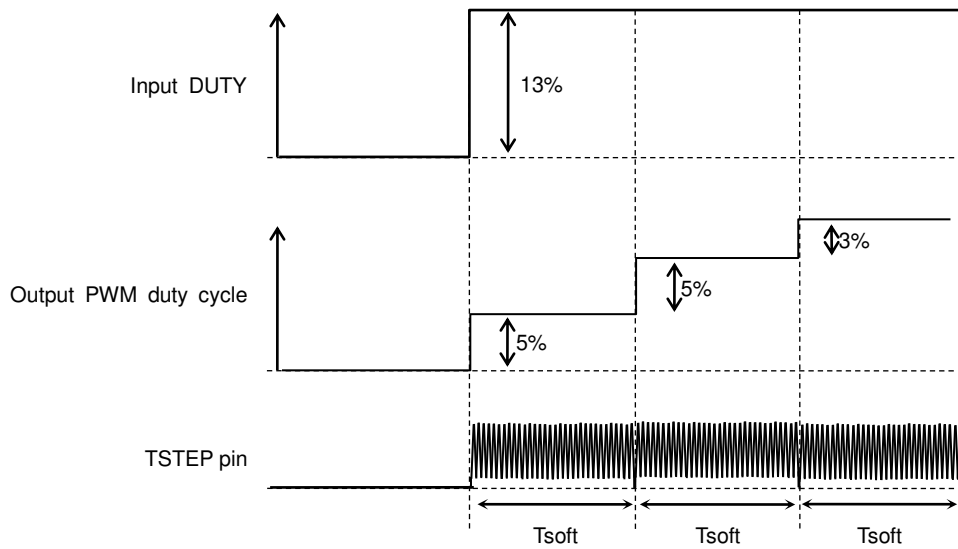

10. Thermal Shutdown Circuit (TSD)

This IC has the thermal shutdown circuit (TSD). When the junction temperature (T_j) exceeds 165°C (typ.), a thermal shutdown circuit makes all output transistors turning off (high impedance). The hysteresis width of a threshold temperature of thermal shutdown circuit is 15°C (typ.).

When the junction temperature is lowered less than 150°C (typ.), this IC begins startup operation after the restart time (T_{re}) that is specified by the value of a capacitor connected to TRE pin has elapsed.

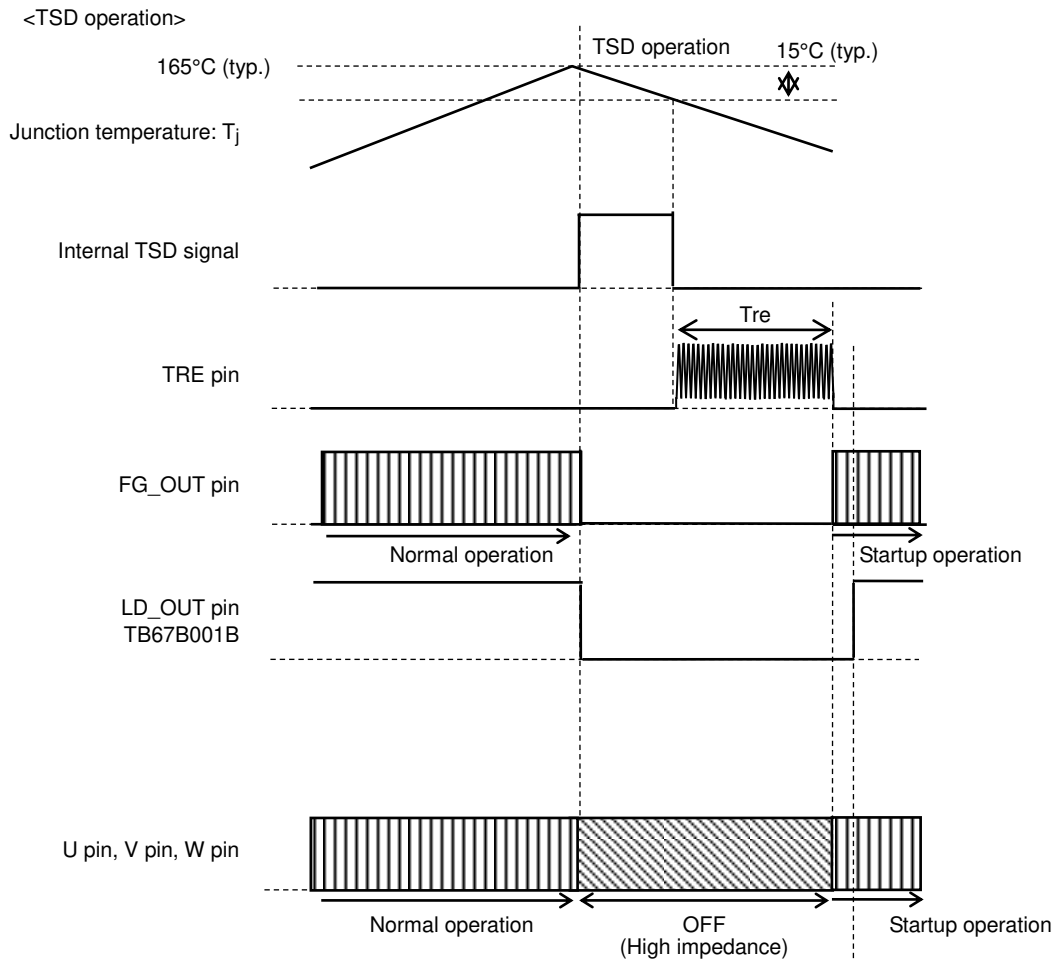

Note: The TSD circuit is activated if the absolute maximum junction temperature rating (T_j) of 150°C is violated. Note that the circuit is provided as an auxiliary only and does not necessarily provide the IC with a perfect protection from any kind of damages.

11. Under voltage Lockout Circuit (UVLO)

This IC includes an under voltage lockout circuit.

It resets the internal logic and makes all output transistors turning off (high-impedance) when VM decreases to 3.4 V (typ.) or less. The hysteresis width of under voltage lockout is 0.3 V (typ.). The releasing voltage is 3.7 V (typ.).

This IC resets the internal logic and makes all output transistors turning off (high-impedance) when VREG decreases to 3.0 V (typ.) or less. The hysteresis width of under voltage lockout is 0.2 V (typ.). The releasing voltage is 3.2 V (typ.).

Note: Wait time in startup depends on the state of the motor; stopping and the rotation number in futile state, etc. It is approximately from 0.017 s to 0.26 s. (ROSC=16kΩ)

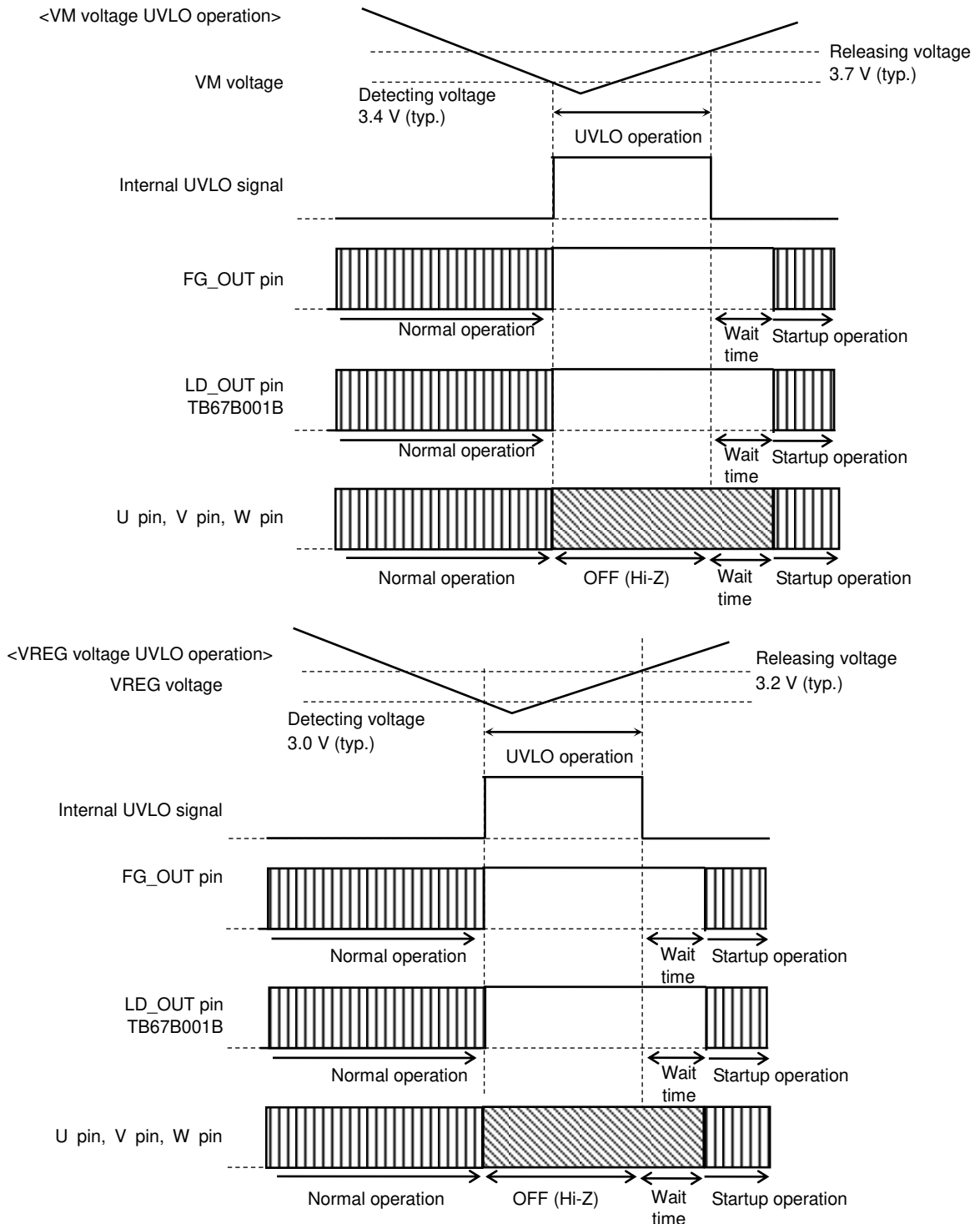

I/O Equivalent Circuits

The equivalent circuit diagrams may be simplified or some parts of them may be omitted for explanatory purposes.

Pin Name	I/O Signal Description	I/O Internal Circuit
SEL_SP SLOP ROT	Control signal inputted via TSP/VSP pin select input pin Soft switching select input pin Rotation speed of lead angle switching select input pin	
CW/CCW	Forward/Reverse rotation direction select input pin	
FST SEL_ADJ LAP	Forced commutation frequency select input pin PWM duty function setting input pin Overlapping commutation select input pin	
ADJ0 ADJ1 ADJ2 ADJ3 LA FPWM	Adjusting pin for characteristics of speed command input Adjusting pin 1 for characteristics of output PWM duty cycle Adjusting pin 2 for characteristics of output PWM duty cycle Adjusting pin 3 for characteristics of output PWM duty cycle Lead angle setting input pin Output PWM frequency select input pin	
VST	Output PWM duty cycle setting pin in DC excitation and forced commutation modes	
TSP/VSP	Speed command input pin (PWM duty cycle control or analog voltage control) in sensorless drive mode	

Pin Name	I/O Signal Description	I/O Internal Circuit
VREG	Reference voltage output	
FG_OUT LD_OUT	Rotation speed detection signal output pin (open-drain) Lock detecting signal output pin (open-drain) An externally attached pull-up resistor enables the High output.	
TEST	Test pin Connect to ground.	
TIP TRE TSTEP	Connection pin for a capacitor to set the DC excitation time Connection pin for a capacitor to set the restart time Connection pin for a capacitor to set the Output PWM duty cycle increasing time	
OSCCR	Connection pin for the oscillator	

Pin Name	I/O Signal Description	I/O Internal Circuit
U V W VM COM RS	U-phase output V-phase output W-phase output Motor power supply pin Connection pin for the center tap of the motor Connection pin for an output shunt resistor	<p>The diagram illustrates the internal power MOSFET bridge circuit. It features three phase legs (U, V, W) and a common return path. The VM pin is connected to the positive supply rail. The COM pin is connected to the center tap of the motor. The RS pin is connected to a shunt resistor, with a note indicating $V_{RS} = 0.25 \text{ V (typ.)}$.</p>

Absolute Maximum Ratings (Note) (Ta = 25 °C)

Characteristics	Symbol	Rating	Unit
Power supply voltage	VM	25	V
Input voltage	V _{IN1} (Note1)	-0.3 to 6.0	V
	V _{IN2} (Note2)	-0.3 to 25	V
	V _{IN3} (Note3)	-0.3 to V _{REG} + 0.3	V
Output voltage	V _{OUT1} (Note4)	25	V
	V _{OUT2} (Note5)	25	V
Output current	I _{OUT1} (Note6)	3 (Note9)	A
	I _{OUT2} (Note7)	10	mA
	I _{OUT3} (Note8)	5	mA
Power dissipation	P _D	2.8 (Note10)	W
Operating temperature	T _{opr}	-40 to 105	°C
Storage temperature	T _{stg}	-55 to 150	°C

Note: The absolute maximum ratings of a semiconductor device are a set of ratings that must not be exceeded, even for a moment. Do not exceed any of these ratings.

Exceeding the rating (s) may cause the device breakdown, damage or deterioration, and may result injury by explosion or combustion.

Please use this IC within the specified operating ranges.

Note1: V_{IN1} is applicable to the voltage at the following pins:

TSP/VSP pin and CW/CCW pin

Note2: V_{IN2} is applicable to the voltage at the following pin:

COM pin.

Note3: V_{IN3} is applicable to the voltage at the following pins.

SLOP pin, ROT pin, SEL_SP pin, ADJ0 pin, ADJ1 pin, ADJ2 pin, ADJ3 pin, OSCCR pin,
VST pin, FPWM pin, LA pin, SEL_ADJ pin, LAP pin, FST pin, TSTEP pin, TIP pin, and TRE pin

Note4: V_{OUT1} is applicable to the voltage at the following pins:

U pin, V pin, and W pin

Note5: V_{OUT2} is applicable to the voltage at the following pins:

FG_OUT pin and LD_OUT pin

Note6: I_{OUT1} is the current from the following pins:

U pin, V pin, and W pin

Note7: I_{OUT2} is the current from the following pins:

FG_OUT pin and LD_OUT pin

Note8: I_{OUT3} is the current from the following pin:

VREG pin.

Note9: Output current may be limited by the ambient temperature or the device implementation. The maximum junction temperature should not exceed 150°C

Note10: When mounted on the PCB (4 layers: FR4: 76.2 mm x 114.3 mm x 1.6 mm)

Operating Ranges

Characteristics	Symbol	Min	Typ.	Max	Unit
Power supply voltage 1	VM _{opr1}	5.5	12	22	V
Power supply voltage 2 (Note1)	VM _{opr2}	4	5	5.5	V
Input frequency of TSP/VSP pin (Note2, 3)	foprTSP	0.5	31.25	125	kHz

Note 1: When voltage of VM is 5.5 V or less, the characteristics of the ON-resistance of output transistor and VREG output voltage change.

Note 2: When the control signal of TSP/VSP pin is the pulse duty (SEL_SP pin = Low).

Note 3: ROSC=16kΩ

Package Power Dissipation (Reference data)

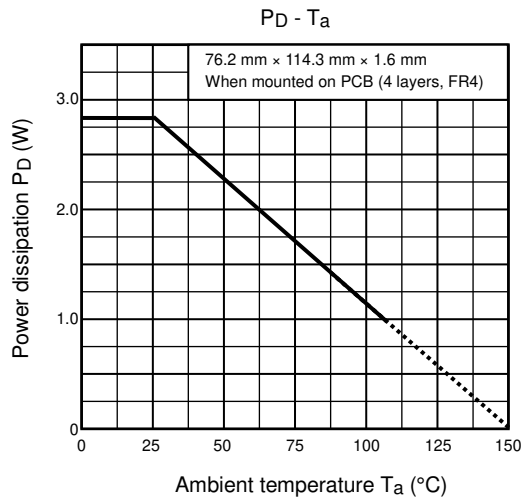

Electrical Characteristics (Ta = 25°C, VM = 12 V, unless otherwise specified)

Characteristics	Symbol	Test Conditions	Min	Typ.	Max	Unit
Static power supply current at VM	IM	When TSP/VSP pin = 0 V	—	5.5	8	mA
Dynamic power supply current at VM	IM(opr)	When TSP/VSP pin = VREG, RS pin = TIP pin = COM pin = 0 V	—	6	8.5	mA
Input current	IIN1(H)	When VIN = 5 V FST, LAP, SEL_ADJ pins	—	100	150	μA
	IIN1(L)	When VIN = 0 V, FST, LAP, SEL_ADJ pins	-150	-100	—	
	IIN2A	When VIN = 0 V to VREG and SEL_SP = VREG TSP/VSP pin	-1	—	1	
	IIN2D(H)	When VIN = VREG and SEL_SP pin = 0 V TSP/VSP pin	—	100	150	
	IIN2D(L)	When VIN = 0 V and SEL_SP pin = 0 V TSP/VSP pin	-1	—	1	
	IIN3	When VIN = 0 V to VREG ADJ0, ADJ1, ADJ2, ADJ3, VST, LA, FPWM pins	-1	—	1	
	IIN4(H)	When VIN = 5 V SEL_SP, CW/CCW, SLOP, ROT pin	—	100	150	
	IIN4(L)	When VIN = 0 V SEL_SP, CW/CCW, SLOP, ROT pin	-1	0	—	
Input voltage	VIN1(H)	When SEL_SP pin = 0 V TSP/VSP pin	2.0	—	—	V
	VIN1(L)		0	—	0.8	
	VIN2(H)	FST, LAP, SEL_ADJ pins	VREG × 0.8	—	VREG + 0.3	
	VIN2(M)		VREG × 0.4	—	VREG × 0.6	
	VIN2(L)		0	—	VREG × 0.2	
	VIN3(H)	SEL_SP, CW/CCW, SLOP, ROT pins	2.0	—	—	
VIN3(L)	SEL_SP, CW/CCW, SLOP, ROT pins	0	—	0.8		
Input voltage hysteresis	V1hys	When SEL_SP pin = 0 V TSP/VSP pin (Reference data)	—	0.12	—	V
	V2hys	SEL_SP, CW/CCW, SLOP pins (Reference data)	—	0.12	—	
Output PWM duty cycle increasing time	Tsoft	When a value of the capacitor connected to TSTEP pin = 0.01 μF (Reference data)	—	0.0986	—	s
DC excitation time	Tip	When a value of the capacitor connected to TIP pin = 0.1 μF (Reference data)	—	0.986	—	s
Restart time	Tre	When a value of the capacitor connected to TRE pin = 1 μF (Reference data)	—	9.86	—	s
High-level output voltage at TIP, TRE, and TSTEP pins	VH	—	2.25	2.5	2.75	V
Low-level output voltage at TIP, TRE, and TSTEP pins	VL	—	0.45	0.5	0.55	V
COM pin input current	ICOM	—	-5	-1.3	1	μA
Position detection comparator offset voltage	Voffset	(Reference data)	-10	0	10	mV
Low-level output voltage at FG_OUT / LD_OUT pins	V_LFG_OUT	When IOUT = 5 mA	0	—	0.5	V
Leakage current at FG_OUT / LD_OUT pins	I_LFG_OUT	When VOUT = 25 V	—	0	2	μA

Characteristics	Symbol	Test Conditions	Min	Typ.	Max	Unit
ON-resistance of Output transistor at the U, V and W pins	RON1(H)	When IOUT = -0.1 A	—	0.3	0.6	Ω
	RON1(L)	When IOUT = 0.1 A	—	0.3	0.6	
	RON2(H)	When IOUT = -0.1 A, VM = 4.0 V	—	0.33	0.6	
	RON2(L)	When IOUT = 0.1 A, VM = 4.0 V	—	0.33	0.6	
Output leakage current at the U, V and W pins	IL(H)	When VOUT = 0 V	-10	0	—	μA
	IL(L)	When VOUT = 25 V	—	0	10	
Output diodes' forward voltage at the U, V and W pins	VF(H)	When IOUT = 1.5 A (Reference data)	—	1.0	1.4	V
	VF(L)	When IOUT = -1.5 A (Reference data)	—	1.0	1.4	
VST ON resistance in power on	RVST	—	—	600	1000	Ω
TSP/VSP I/O characteristics in analog voltage control	VAD(L)	Voltage of TSP/VSP pin when output PWM duty cycle = 0% in SEL_SP pin = High	0.56	0.625	0.69	V
	VAD(H)	Voltage of TSP/VSP pin when output PWM duty cycle = 100% in SEL_SP pin = High	2.81	3.125	—	
Masking time of current limit detection	TRS	(Reference data) ROSC=16kΩ	—	2.4	—	μs
Voltage of RS pin for current limit detection	VRS	—	0.225	0.25	0.275	V
PWM oscillation frequency	FPWM4	(Reference data), ROSC=16kΩ	214.425	238.25	262.075	kHz
	FPWM3	(Reference data), ROSC=16kΩ	107.212	119.125	131.038	
	FPWM2	(Reference data), ROSC=16kΩ	53.662	59.625	65.588	
	FPWM1	(Reference data), ROSC=16kΩ	26.775	29.75	32.725	
OSC frequency1	OSC1	When R = 16kΩ and C = 180 pF (Reference data)	13.73	15.25	16.77	MHz
OSC frequency2	OSC2	When R = 20kΩ and C = 180 pF (Reference data)	10.98	12.2	13.42	MHz
Masking time of overcurrent protection circuit	TISD	(Reference data) , ROSC=16kΩ	—	2.4	—	μs
Threshold current of overcurrent protection circuit	IISD	(Reference data)	3	4.5	6	A
Threshold temperature of thermal shutdown circuit	TSD	(Reference data)	—	165	—	°C
	TSDhys	Hysteresis width (Reference data)	—	15	—	
UVLO detection voltage at the VM pin	VMUVLO	—	3.1	3.4	3.7	V
UVLO releasing voltage at the VM pin	VMUVLOR	—	3.4	3.7	3.98	V
UVLO detection voltage at the VREG pin	VREGUVLO	—	2.7	3.0	3.3	V
UVLO releasing voltage at the VREG pin	VREGUVLOR	—	2.9	3.2	3.45	V
VREG output voltage	VREG1	When IVREG = -5 mA	4.5	5	5.5	V
	VREG2	When IVREG = -5 mA, VM = 4.0 V	3.6	3.9	4.0	V

Note: The characteristics which has "Reference data" does not implement testing before shipping.

Application Circuit Example

Some of the functional blocks, circuits, or constants in the block diagram may be omitted or simplified for explanatory purposes.

The application circuits shown in this document are provided for reference purposes only. Thorough evaluation is required, especially at the mass production design stage.

Providing these application circuit examples does not grant a license for industrial property rights.

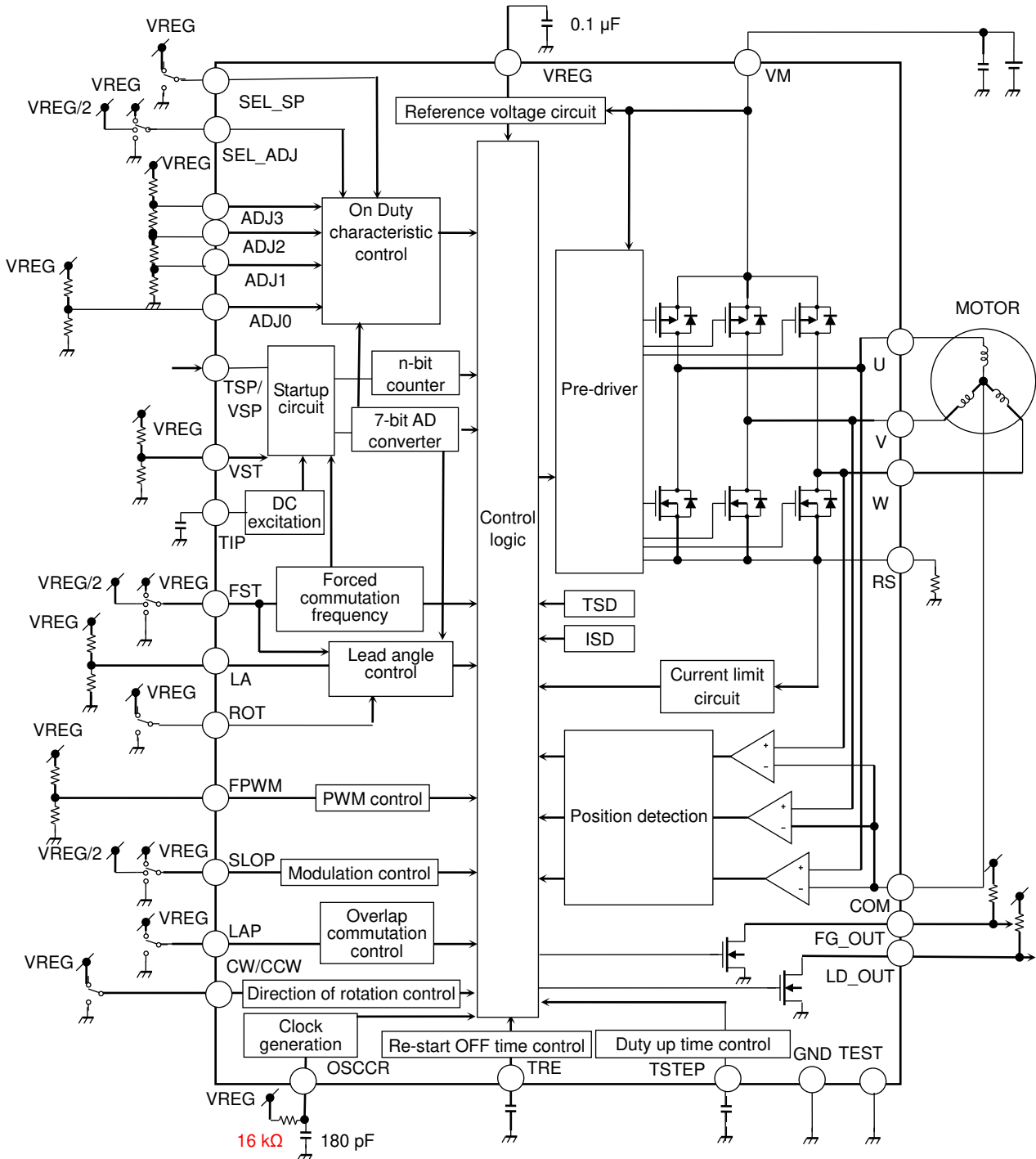

Package Dimensions

P-VQFN36-0505-0.50-001

Unit: mm

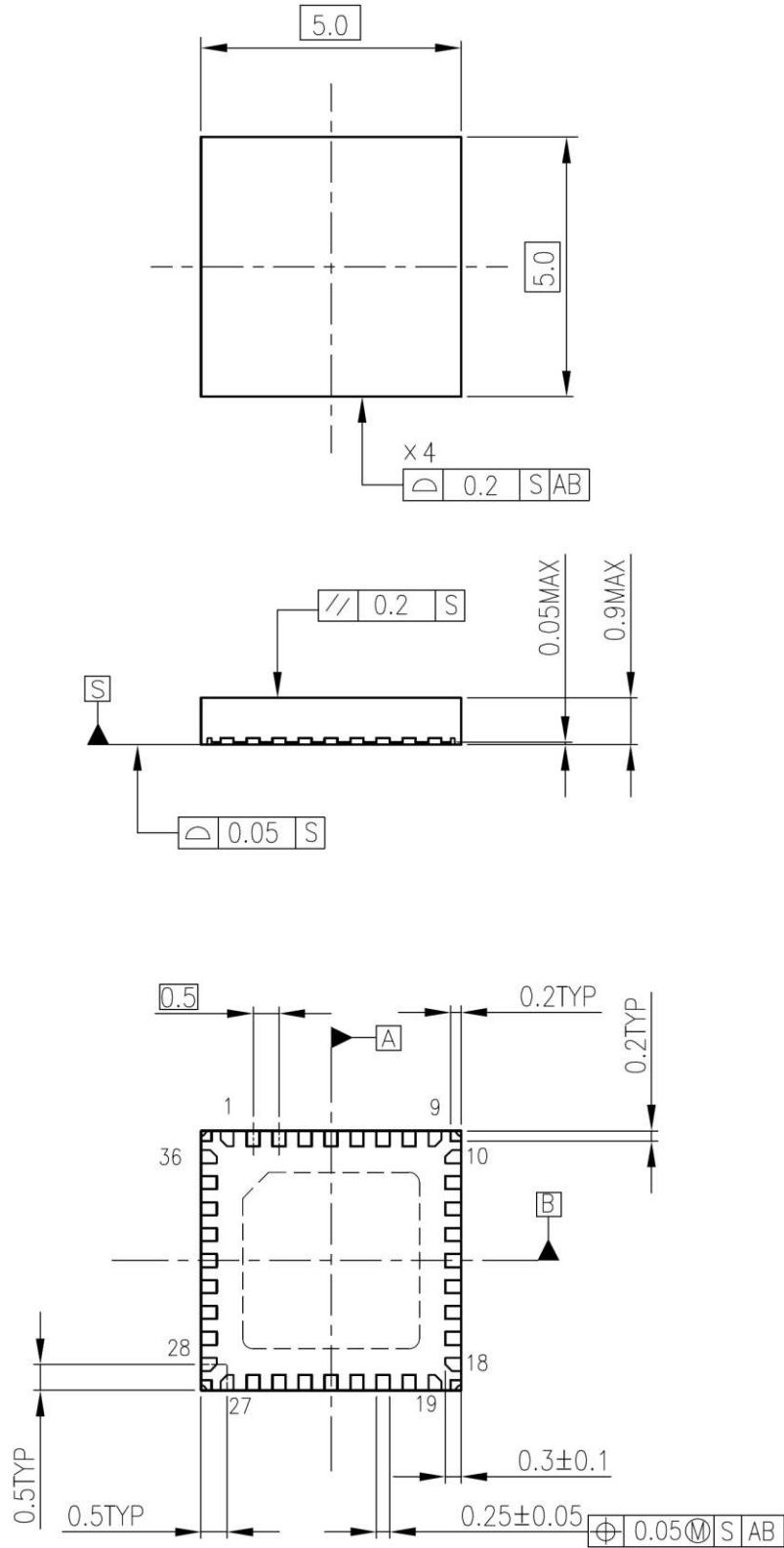

Weight: 0.05 g (typ.)

Notes on Contents

1. Block Diagrams

Some of the functional blocks, circuits, or constants in the block diagram may be omitted or simplified for explanatory purposes.

2. Equivalent Circuits

The equivalent circuit diagrams may be simplified or some parts of them may be omitted for explanatory purposes.

3. Timing Charts

Timing charts may be simplified for explanatory purposes.

4. Application Circuits

The application circuits shown in this document are provided for reference purposes only. Thorough evaluation is required, especially at the mass production design stage.

Providing these application circuit examples does not grant a license for industrial property rights.

IC Usage Considerations

Notes on handling of ICs

- (1) The absolute maximum ratings of a semiconductor device are a set of ratings that must not be exceeded, even for a moment. Do not exceed any of these ratings.
Exceeding the rating(s) may cause the device breakdown, damage or deterioration, and may result injury by explosion or combustion.
- (2) Use an appropriate power supply fuse to ensure that a large current does not continuously flow in case of over current and/or IC failure. The IC will fully break down when used under conditions that exceed its absolute maximum ratings, when the wiring is routed improperly or when an abnormal pulse noise occurs from the wiring or load, causing a large current to continuously flow and the breakdown can lead smoke or ignition. To minimize the effects of the flow of a large current in case of breakdown, appropriate settings, such as fuse capacity, fusing time and insertion circuit location, are required.
- (3) If your design includes an inductive load such as a motor coil, incorporate a protection circuit into the design to prevent device malfunction or breakdown caused by the current resulting from the inrush current at power ON or the negative current resulting from the back electromotive force at power OFF. IC breakdown may cause injury, smoke or ignition.
Use a stable power supply with ICs with built-in protection functions. If the power supply is unstable, the protection function may not operate, causing IC breakdown. IC breakdown may cause injury, smoke or ignition.
- (4) Do not insert devices in the wrong orientation or incorrectly.
Make sure that the positive and negative terminals of power supplies are connected properly.
Otherwise, the current or power consumption may exceed the absolute maximum rating, and exceeding the rating(s) may cause the device breakdown, damage or deterioration, and may result injury by explosion or combustion.
In addition, do not use any device that is applied the current with inserting in the wrong orientation or incorrectly even just one time.

Points to Remember on Handling of ICs

- (1) Over current protection circuit
Over current protection circuits (referred to as current limiter circuits) do not necessarily protect ICs under all circumstances. If the Over current protection circuits operate against the over current, clear the over current status immediately.
Depending on the method of use and usage conditions, such as exceeding absolute maximum ratings can cause the over current protection circuit to not operate properly or IC breakdown before operation. In addition, depending on the method of use and usage conditions, if over current continues to flow for a long time after operation, the IC may generate heat resulting in breakdown.
- (2) Heat radiation design
In using an IC with large current flow such as power amp, regulator or driver, please design the device so that heat is appropriately radiated, not to exceed the specified junction temperature (T_J) at any time and condition. These ICs generate heat even during normal use. An inadequate IC heat radiation design can lead to decrease in IC life, deterioration of IC characteristics or IC breakdown. In addition, please design the device taking into considerate the effect of IC heat radiation with peripheral components.
- (3) Back-EMF
When a motor rotates in the reverse direction, stops or slows down abruptly, a current flow back to the motor's power supply due to the effect of back-EMF. If the current sink capability of the power supply is small, the device's motor power supply and output pins might be exposed to conditions beyond absolute maximum ratings. To avoid this problem, take the effect of back-EMF into consideration in system design.

RESTRICTIONS ON PRODUCT USE

Toshiba Corporation and its subsidiaries and affiliates are collectively referred to as "TOSHIBA".

Hardware, software and systems described in this document are collectively referred to as "Product".

- TOSHIBA reserves the right to make changes to the information in this document and related Product without notice.
- This document and any information herein may not be reproduced without prior written permission from TOSHIBA. Even with TOSHIBA's written permission, reproduction is permissible only if reproduction is without alteration/omission.
- Though TOSHIBA works continually to improve Product's quality and reliability, Product can malfunction or fail. Customers are responsible for complying with safety standards and for providing adequate designs and safeguards for their hardware, software and systems which minimize risk and avoid situations in which a malfunction or failure of Product could cause loss of human life, bodily injury or damage to property, including data loss or corruption. Before customers use the Product, create designs including the Product, or incorporate the Product into their own applications, customers must also refer to and comply with (a) the latest versions of all relevant TOSHIBA information, including without limitation, this document, the specifications, the data sheets and application notes for Product and the precautions and conditions set forth in the "TOSHIBA Semiconductor Reliability Handbook" and (b) the instructions for the application with which the Product will be used with or for. Customers are solely responsible for all aspects of their own product design or applications, including but not limited to (a) determining the appropriateness of the use of this Product in such design or applications; (b) evaluating and determining the applicability of any information contained in this document, or in charts, diagrams, programs, algorithms, sample application circuits, or any other referenced documents; and (c) validating all operating parameters for such designs and applications. **TOSHIBA ASSUMES NO LIABILITY FOR CUSTOMERS' PRODUCT DESIGN OR APPLICATIONS.**
- **PRODUCT IS NEITHER INTENDED NOR WARRANTED FOR USE IN EQUIPMENTS OR SYSTEMS THAT REQUIRE EXTRAORDINARILY HIGH LEVELS OF QUALITY AND/OR RELIABILITY, AND/OR A MALFUNCTION OR FAILURE OF WHICH MAY CAUSE LOSS OF HUMAN LIFE, BODILY INJURY, SERIOUS PROPERTY DAMAGE AND/OR SERIOUS PUBLIC IMPACT ("UNINTENDED USE").** Except for specific applications as expressly stated in this document, Unintended Use includes, without limitation, equipment used in nuclear facilities, equipment used in the aerospace industry, medical equipment, equipment used for automobiles, trains, ships and other transportation, traffic signaling equipment, equipment used to control combustions or explosions, safety devices, elevators and escalators, devices related to electric power, and equipment used in finance-related fields. **IF YOU USE PRODUCT FOR UNINTENDED USE, TOSHIBA ASSUMES NO LIABILITY FOR PRODUCT.** For details, please contact your TOSHIBA sales representative.
- Do not disassemble, analyze, reverse-engineer, alter, modify, translate or copy Product, whether in whole or in part.
- Product shall not be used for or incorporated into any products or systems whose manufacture, use, or sale is prohibited under any applicable laws or regulations.
- The information contained herein is presented only as guidance for Product use. No responsibility is assumed by TOSHIBA for any infringement of patents or any other intellectual property rights of third parties that may result from the use of Product. No license to any intellectual property right is granted by this document, whether express or implied, by estoppel or otherwise.
- **ABSENT A WRITTEN SIGNED AGREEMENT, EXCEPT AS PROVIDED IN THE RELEVANT TERMS AND CONDITIONS OF SALE FOR PRODUCT, AND TO THE MAXIMUM EXTENT ALLOWABLE BY LAW, TOSHIBA (1) ASSUMES NO LIABILITY WHATSOEVER, INCLUDING WITHOUT LIMITATION, INDIRECT, CONSEQUENTIAL, SPECIAL, OR INCIDENTAL DAMAGES OR LOSS, INCLUDING WITHOUT LIMITATION, LOSS OF PROFITS, LOSS OF OPPORTUNITIES, BUSINESS INTERRUPTION AND LOSS OF DATA, AND (2) DISCLAIMS ANY AND ALL EXPRESS OR IMPLIED WARRANTIES AND CONDITIONS RELATED TO SALE, USE OF PRODUCT, OR INFORMATION, INCLUDING WARRANTIES OR CONDITIONS OF MERCHANTABILITY, FITNESS FOR A PARTICULAR PURPOSE, ACCURACY OF INFORMATION, OR NONINFRINGEMENT.**
- Do not use or otherwise make available Product or related software or technology for any military purposes, including without limitation, for the design, development, use, stockpiling or manufacturing of nuclear, chemical, or biological weapons or missile technology products (mass destruction weapons). Product and related software and technology may be controlled under the applicable export laws and regulations including, without limitation, the Japanese Foreign Exchange and Foreign Trade Law and the U.S. Export Administration Regulations. Export and re-export of Product or related software or technology are strictly prohibited except in compliance with all applicable export laws and regulations.
- Please contact your TOSHIBA sales representative for details as to environmental matters such as the RoHS compatibility of Product. Please use Product in compliance with all applicable laws and regulations that regulate the inclusion or use of controlled substances, including without limitation, the EU RoHS Directive. **TOSHIBA ASSUMES NO LIABILITY FOR DAMAGES OR LOSSES OCCURRING AS A RESULT OF NONCOMPLIANCE WITH APPLICABLE LAWS AND REGULATIONS.**

TOSHIBA ELECTRONIC DEVICES & STORAGE CORPORATION

<https://toshiba.semicon-storage.com/>