

THIS DRAWING IS UNPUBLISHED. RELEASED FOR PUBLICATION
 © COPYRIGHT BY TYCO ELECTRONICS CORPORATION. ALL RIGHTS RESERVED.

LOC		DIST		REVISIONS			
GP	00	P	LTR	DESCRIPTION	DATE	DWN	APVD
		L		REVISED PER ECO-10--000073	15FEB2010	CJV	SB

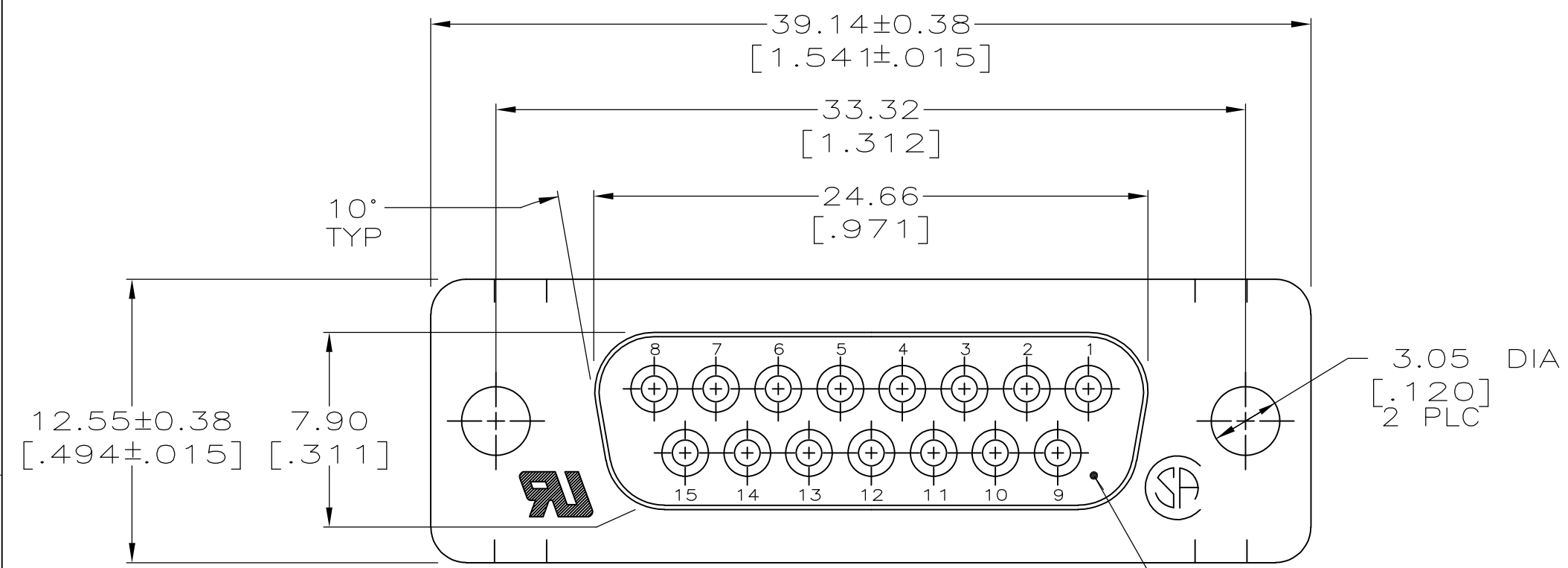

- ⚠ MOLDED PARTS: FLAME RETARDANT 94V-0 RATED THERMOPLASTIC; BLACK.
SHELLS: CARBON STEEL.
CONTACTS: PHOS BRONZE.
- ⚠ SHELLS: 5.08μm [.000200] MIN TIN OR TIN-LEAD OVER 2.54μm [.000100] MIN COPPER.
CONTACTS: GOLD FLASH ON MATING END, 2.54μm [.000100] MIN TIN-LEAD ON SOLDER END, BOTH OVER 1.27μm [.000050] MIN NICKEL.
- ⚠ SHELLS: 5.08μm [.000200] MIN TIN OVER 2.54μm [.000100] MIN COPPER.
CONTACTS: 0.76μm [.000030] MIN GOLD ON MATING END, 2.54μm [.000100] MIN TIN-LEAD ON SOLDER END, BOTH OVER 1.27μm [.000050] MIN NICKEL.
-OR-
GOLD FLASH OVER PALLADIUM-NICKEL 0.76μm [.000030] MIN TOTAL ON MATING END, 2.54μm [.000100] MIN TIN-LEAD ON SOLDER END, BOTH OVER 1.27μm [.000050] MIN NICKEL.

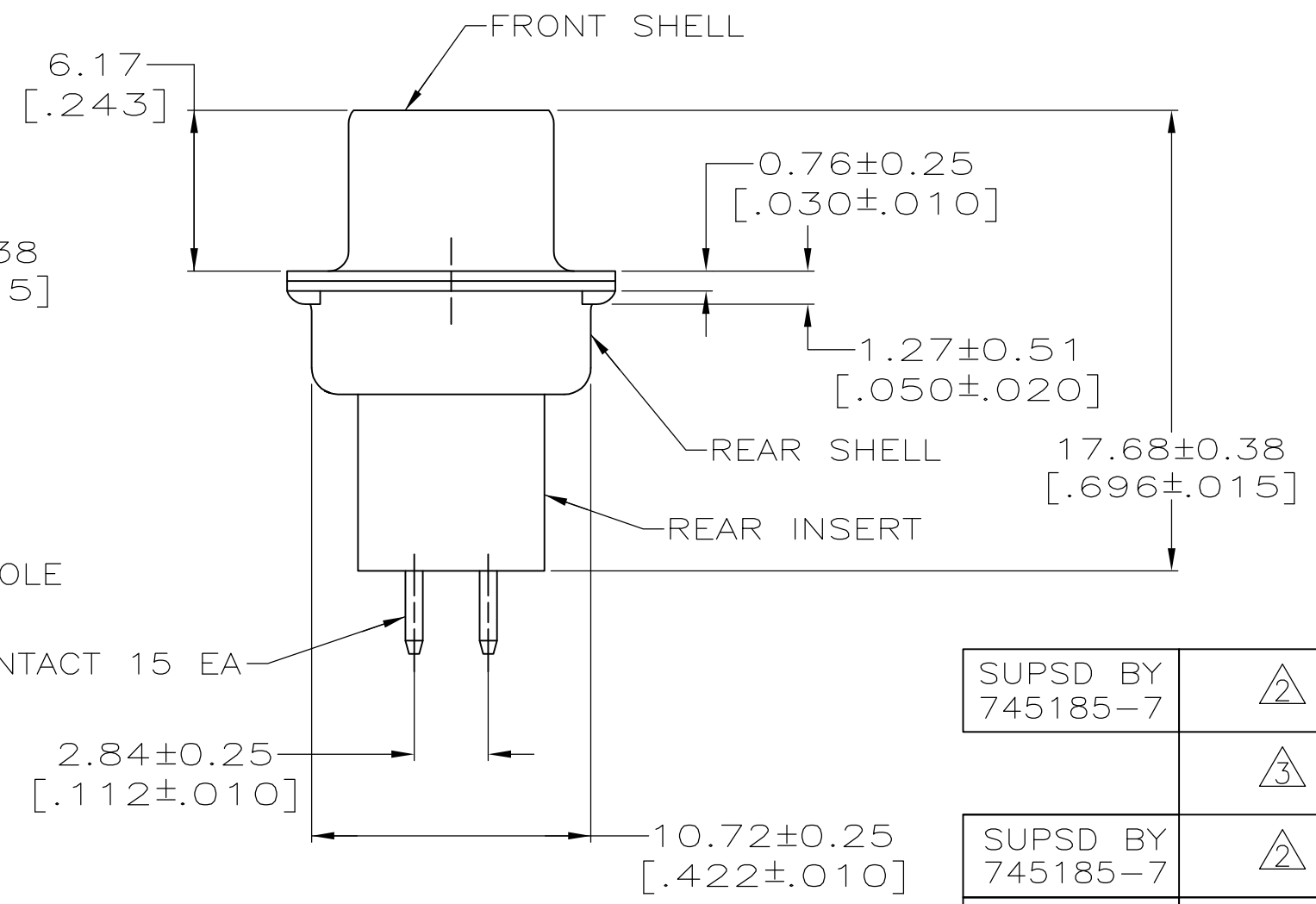
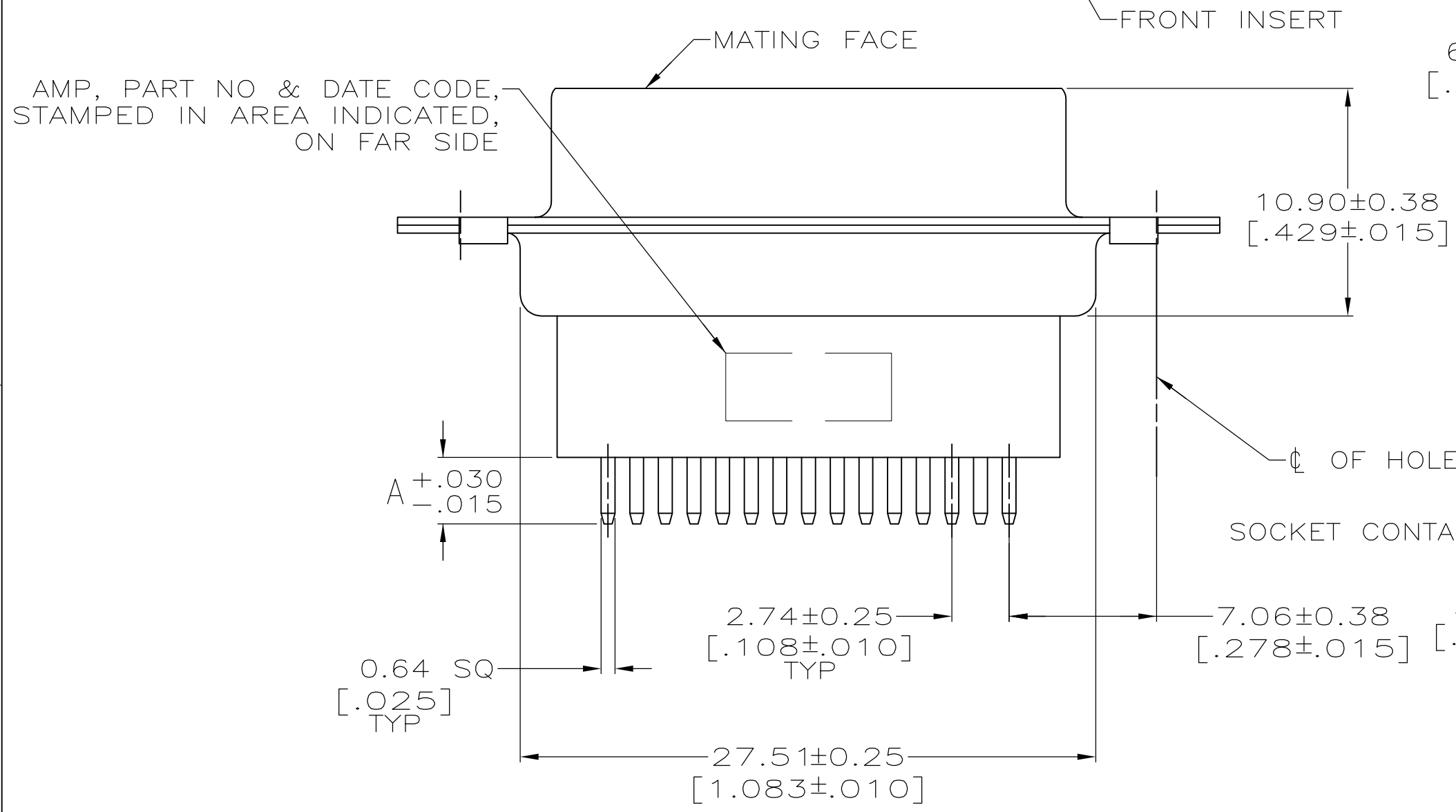

SUPSD BY 745185-7	⚠	4.78 [0.188]	745185-8
	⚠	4.78 [0.188]	745185-7
SUPSD BY 745185-7	⚠	16.54 [0.651]	745185-6
OBSOLETE	⚠	16.54 [0.651]	745185-5
OBSOLETE	-	-	745185-4
SUPSD BY 745185-7	⚠	10.85 [0.427]	745185-3
SUPSD BY 745185-1	⚠	3.18 [0.125]	745185-2
	⚠	3.18 [0.125]	745185-1
	GOLD FINISH	A	PART NUMBER

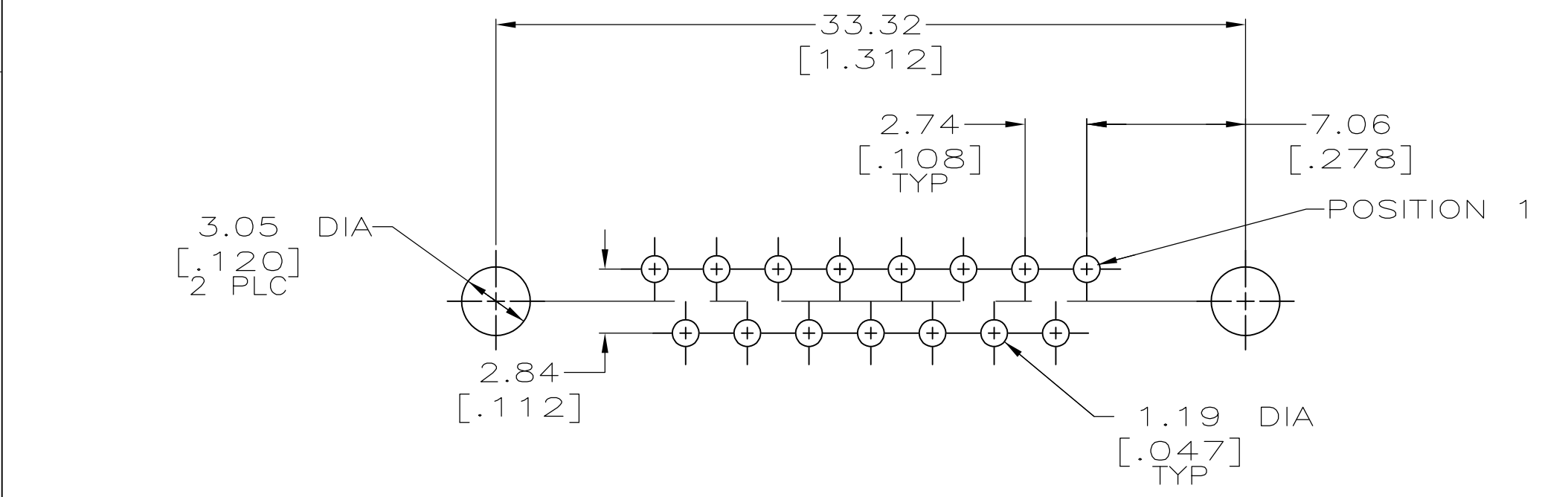

P.C. BOARD MOUNTING DIMENSIONS

THIS DRAWING IS A CONTROLLED DOCUMENT.		DWN 07 AUG 95 C.REIFSNYDER	Tyco Electronics Corporation Harrisburg, PA 17105-3608	
DIMENSIONS: mm [INCHES]		CHK 23 AUG 95 R.STONE	NAME RECEPTACLE ASSY, SIZE 2 15 POS, VERTICAL, TM	
TOLERANCES UNLESS OTHERWISE SPECIFIED:		APVD 23 AUG 95 R.TAYLOR	PRODUCT SPEC 108-40005	
0 PLC ± -		APPLICATION SPEC 114-40013		
1 PLC ± -		WEIGHT -		
2 PLC ± 0.13 [.005]		SIZE A2		
3 PLC ± -		CAGE CODE 00779		
4 PLC ± -		DRAWING NO C=745185		
ANGLES ± 2°		RESTRICTED TO -		
FINISH SEE TABLE		SCALE NTS SHEET 1 OF 1 REV L		
MATERIAL ⚠		CUSTOMER DRAWING		