



145 Royal Crest Court Unit 42 Markham, ON, Canada L3R 9Z4
Tel: 905-477-1166 Fax: 905-477-1782 <http://www.orientdisplay.com>

SPECIFICATION FOR LCM MODULE

MODULE NO.: AMG12864JR-B-Y6WFDY-NV
DOC.REVISION 00

Customer Approval:

--

	SIGNATURE	DATE
PREPARED BY (RD ENGINEER)		
PREPARED BY (QA ENGINEER)		
CHECKED BY		
APPROVED BY		

DOCUMENT REVISION HISTORY

Version	DATE	DESCRIPTION	CHANGED BY
00	May-6-2008	First issue	

CONTENTS

1. Functions & Features	1
2. Mechanical specifications	1
3. Block diagram	1
4. Dimensional Outline	2
5. Pin description	3
6. Maximum absolute limit	3
7. Electrical characteristics	3
8. Backlight Characteristics	4
9. Electro-Optical characteristics	4
10. Timing Characteristics	5
11. Control and display command	6
12. Precaution for using LCD/LCM	7-8
13. LCM test criteria	9~17

1. FUNCTIONS & FEATURES

1.1. Format	: 128x64Dots
1.2. LCD mode	: STN / Positive Transflective Mode/Y-G
1.3. Viewing direction	: 6 O'clock
1.4. Driving scheme	: 1/64 Duty cycle, 1/7 Bias
1.5. Power supply voltage (V _{DD})	: 5.0V
1.6. LCD driving voltage	: 7.2V (Operating voltage)
1.7. Operation temp	: -20~70°C
1.8. Storage temp	: -30~80°C
1.9. Backlight color	: Yellow-green
1.10.ROHS Standard	

2. MECHANICAL SPECIFICATIONS

2.1. Module size	: 75.0mm(L)*52.8mm(W)*9.0max mm(H)
2.2. Viewing area	: 60.0*mm(L)*32.6mm(W)
2.3. Dot pitch	: 0.43mm(L)*0.43mm(W)
2.4. Dot size	: 0.40mm(L)*0.40mm(W)
2.5. Weight	: Approx.

3. BLOCK DIAGRAM

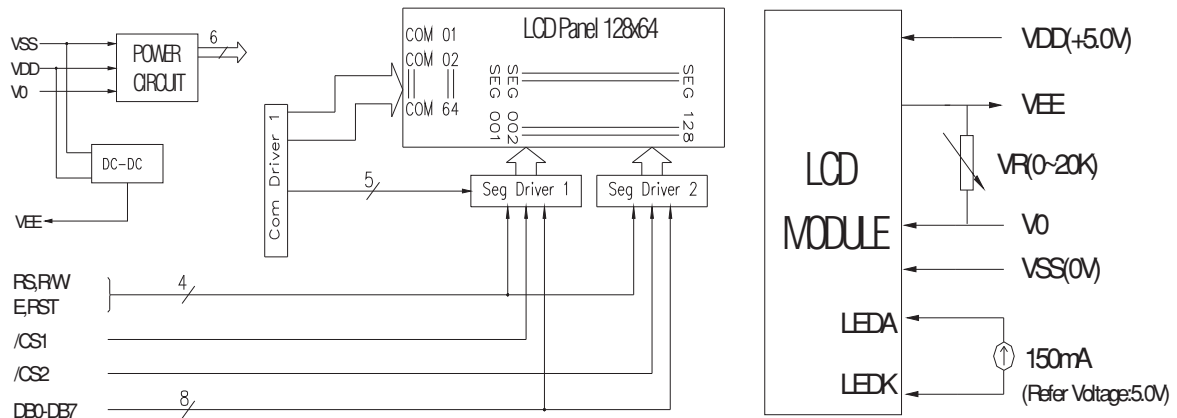

Figure 1. Block Diagram

4. DIMENSIONAL OUTLINE

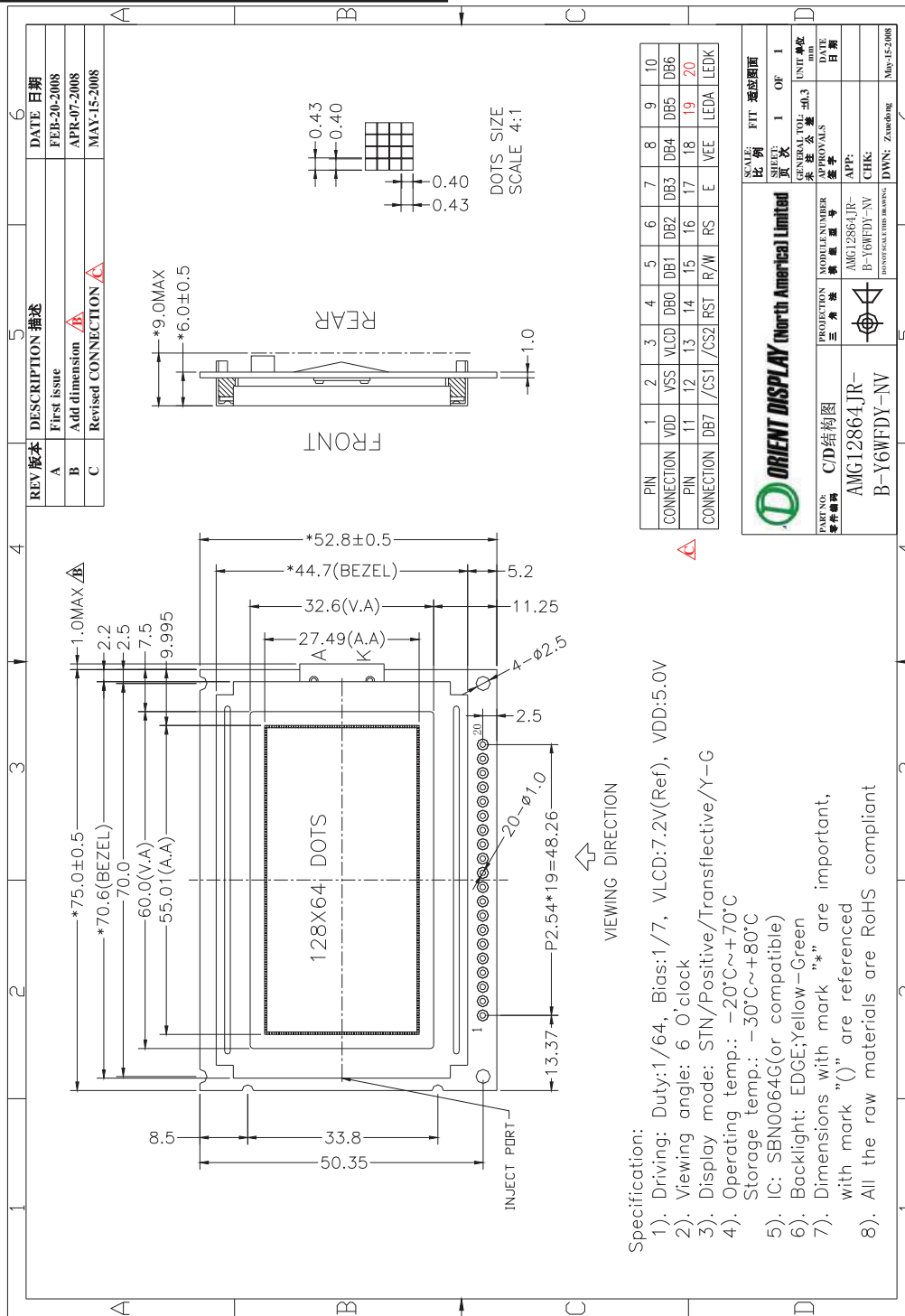

Figure 2. Dimensional Outline

5. PIN DESCRIPTION

No.	Symbol	Function
1	VDD	Power supply(+5.0V)
2	VSS	GND(0V)
3	VO	Supply voltage for LCD
4~11	DB0~DB7	Data bus line
12	/CS1	Chip select signal for left half of the screen(Low select)
13	/CS2	Chip select signal for right half of the screen(Low select)
14	RST	Reset signal
15	R/W	Read /write selection. (H: Read L: write)
16	RS	Register selection. (H: Data register L: Instruction register)
17	E	Enable signal for chip
18	VEE	Output of supply negative voltage by the DC-DC converter on the module
19	LEDA	Power supply for backlight(+)
20	LEDK	Power supply for backlight(-)

6. MAXIMUM ABSOLUTE LIMIT

Item	Symbol	MIN	MAX	Unit
Supply Voltage for Logic	V _{DD}	-0.3	7.0	V
Supply Voltage for LCD	V ₀	V _{DD} -16.0	---	V
Input Voltage	V _{in}	-0.3	V _{DD} +0.3	V
Supply Current for Backlight	I _F (Ta = 25°C)	---	150+150*20%	mA
Reverse Voltage for Backlight	V _R (Ta = 25°C)	---	10	V
Operating Temperature	Top	-20	70	°C
Storage Temperature	T _{st}	-30	80	°C

7. ELECTRICAL CHARACTERISTICS

Item	Symbol	Condition	Min	Typ	Max	Unit
Supply Voltage for Logic	V _{DD} -V _{SS}	Ta = 25°C	4.75	5.0	5.25	V
Input High Voltage	V _{IH}	Ta = 25°C	V _{DD} -2.2	---	V _{DD}	V
Input Low Voltage	V _{IL}	Ta = 25°C	0	---	0.8	V
Output High Voltage	V _{OH}	Ta = 25°C	V _{DD} -0.3	---	V _{DD}	V
Output Low Voltage	V _{OL}	Ta = 25°C	0	---	0.3	V
Supply Current	I _{DD}	Ta = 25°C	---	8	10	mA

8. BACKLIGHT CHARACTERISTICS

Ta = 25°C

Item	Symbol	Condition	Min	Typ	Max	Unit
Forward Voltage	VF	IF=150mA	4.0	4.2	4.4	V
Reverse Current	IR	VR=10V	---	0.1	---	mA
Luminous Intensity (Without LCD)	IV	IF=150mA	35	50	---	Cd/m ²
Wave length(Without LCD)	λρ	IF=150mA	569	572	574	nm
Color	Yellow-green					

Note:

For operation above 25°C ,The Ifm must be derated ,the Curent derating is $-0.36 \times 10\text{mA}/^\circ\text{C}$ for DC drive. The product working current must not more than the 60% of the Ifm according to the working temperature.

9. ELECTRO-OPTICAL CHARACTERISTICS

(VDD=5.0V, Ta = 25°C)

Item	Symbol	Condition	Min	Typ	Max	Unit
Operating Voltage	Vop	Ta = -20C	7.3	7.7	8.1	V
		Ta = 25°C	6.8	7.2	7.6	
		Ta = 70C	6.3	6.7	7.1	
Response time	Tr	Ta = 25°C	---	185	---	ms
	Tf		---	200	---	ms
Contrast	Cr	Ta = 25°C	---	4	---	---
Viewing angle range	θ	Cr≥2	-40	---	+40	deg
	Φ		-40	---	+40	deg

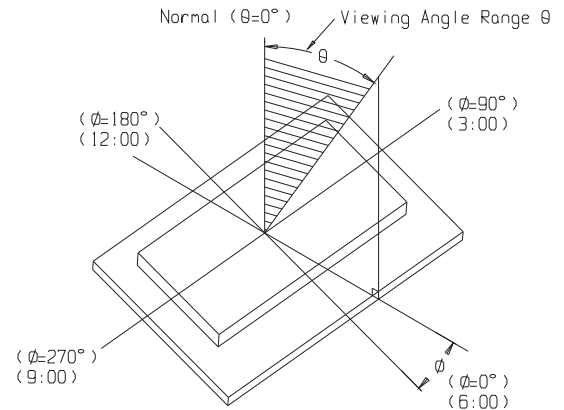
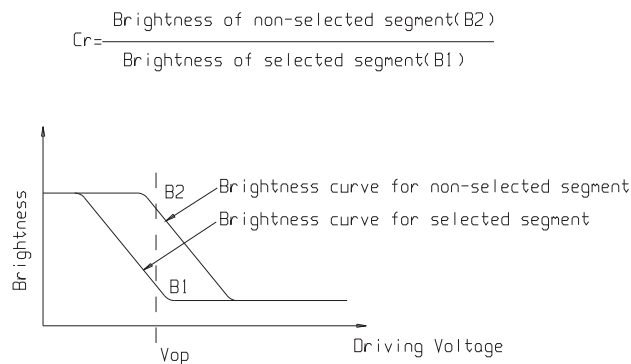

10. TIMING CHARACTERISTICS

(Please refer AVANT SBN0064G DATASHEETS)

Characteristic	Symbol	Min	Typ	Max	Unit
E cycle	t_C	1000	-	-	ns
E high level width	t_{WH}	450	-	-	ns
E low level width	t_{WL}	450	-	-	ns
E rise time	t_R	-	-	25	ns
E fall time	t_F	-	-	25	ns
Address set-up time	t_{ASU}	140	-	-	ns
Address hold time	t_{AH}	10	-	-	ns
Data set-up time	t_{DSU}	200	-	-	ns
Data delay time	t_D	-	-	320	ns
Data hold time (write)	t_{DHW}	10	-	-	ns
Data hold time (read)	t_{DHR}	20	-	-	ns

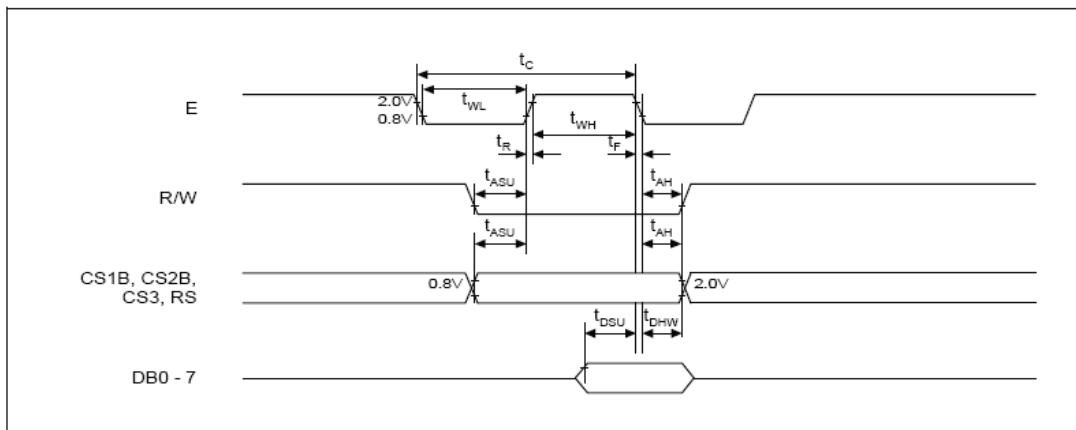

MPU write timing

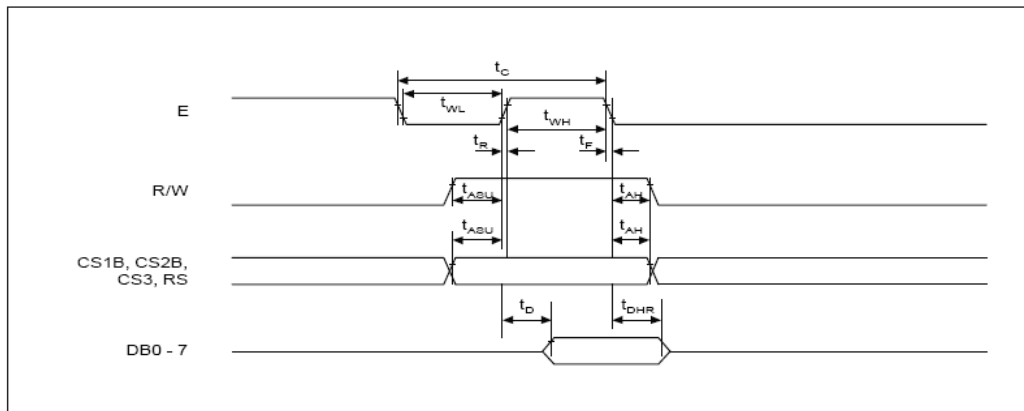

MPU read timing

11. CONTROL AND DISPLAY INSTRUCTION

(Please refer AVANT SBN0064G DATASHEETS)

Instruction	RS	R/W	DB7	DB6	DB5	DB4	DB3	DB2	DB1	DB0	Function	
Display on/off	L	L	L	L	H	H	H	H	H	L/H	Controls the display on or off. Internal status and display RAM data is not affected. L: OFF, H: ON	
Set address (Y address)	L	L	L	H	Y address (0 - 63)						Sets the Y address in the Y address counter.	
Set page (X address)	L	L	H	L	H	H	H	Page (0 - 7)			Sets the X address at the X address register.	
Display start line (Z address)	L	L	H	H	Display start line (0 - 63)						Indicates the display data RAM displayed at the top of the screen.	
Status read	L	H	Busy	L	On / Off	Reset	L	L	L	L	Read status. BUSY L: Ready H: In operation ON/OFF L: Display ON H: Display OFF RESET L: Normal H: Reset	
Write display data	H	L	Write data									Writes data (DB0:7) into display data RAM. After writing instruction, Y address is increased by 1 automatically.
Read display data	H	H	Read data									Reads data (DB0: 7) from display data RAM to the data bus.

12. PRECAUTION FOR USING LCD/LCM

After reliability test, recovery time should be 24 hours minimum. Moreover, functions, performance and appearance shall be free from remarkable deterioration within 50,000 hours under ordinary operating and storage conditions room temperature ($20\pm 8^{\circ}\text{C}$), normal humidity (below 65% RH), and in the area not exposed to direct sun light. Using LCM beyond these conditions will shorten the life time.

Precaution for using LCD/LCM

LCD/LCM is assembled and adjusted with a high degree of precision. Do not attempt to make any alteration or modification. The followings should be noted.

General Precautions:

1. LCD panel is made of glass. Avoid excessive mechanical shock or applying strong pressure onto the surface of display area.
2. The polarizer used on the display surface is easily scratched and damaged. Extreme care should be taken when handling. To clean dust or dirt off the display surface, wipe gently with cotton, or other soft material soaked with isopropyl alcohol, ethyl alcohol or trichlorotrifluoroethane, do not use water, ketone or aromatics and never scrub hard.
3. Do not tamper in any way with the tabs on the metal frame.
4. Do not made any modification on the PCB without consulting Orient Display.
5. When mounting a LCM, make sure that the PCB is not under any stress such as bending or twisting. Elastomer contacts are very delicate and missing pixels could result from slight dislocation of any of the elements.
6. Avoid pressing on the metal bezel, otherwise the elastomer connector could be deformed and lose contact, resulting in missing pixels and also cause rainbow on the display.
7. Be careful not to touch or swallow liquid crystal that might leak from a damaged cell. Any liquid crystal adheres to skin or clothes, wash it off immediately with soap and water.

Static Electricity Precautions:

1. CMOS-LSI is used for the module circuit; therefore operators should be grounded whenever he/she comes into contact with the module.
2. Do not touch any of the conductive parts such as the LSI pads; the copper leads on the PCB and the interface terminals with any parts of the human body.
3. Do not touch the connection terminals of the display with bare hand; it will cause disconnection or defective insulation of terminals.
4. The modules should be kept in anti-static bags or other containers resistant to static for storage.

5. Only properly grounded soldering irons should be used.
6. If an electric screwdriver is used, it should be grounded and shielded to prevent sparks.
7. The normal static prevention measures should be observed for work clothes and working benches.
8. Since dry air is inductive to static, a relative humidity of 50-60% is recommended.

Soldering Precautions:

1. Soldering should be performed only on the I/O terminals.
2. Use soldering irons with proper grounding and no leakage.
3. Soldering temperature: $350^{\circ}\text{C}\pm 10^{\circ}\text{C}$
4. Soldering time: 3 to 4 second.
5. Use eutectic solder with resin flux filling.
6. If flux is used, the LCD surface should be protected to avoid spattering flux.
7. Flux residue should be removed.

Operation Precautions:

1. The viewing angle can be adjusted by varying the LCD driving voltage V_o .
2. Since applied DC voltage causes electro-chemical reactions, which deteriorate the display, the applied pulse waveform should be a symmetric waveform such that no DC component remains. Be sure to use the specified operating voltage.
3. Driving voltage should be kept within specified range; excess voltage will shorten display life.
4. Response time increases with decrease in temperature.
5. Display color may be affected at temperatures above its operational range.
6. Keep the temperature within the specified range usage and storage. Excessive temperature and humidity could cause polarization degradation, polarizer peel-off or generate bubbles.
7. For long-term storage over 40°C is required, the relative humidity should be kept below 60%, and avoid direct sunlight.

Limited Warranty

Orient Display LCDs and modules are not consumer products, but may be incorporated by Orient Display's customers into consumer products or components thereof, Orient Display does not warrant that its LCDs and components are fit for any such particular purpose.

1. The liability of Orient Display is limited to repair or replacement on the terms set forth below. Orient Display will not be responsible for any subsequent or consequential events or injury or damage to any personnel or user including third party personnel and/or user. Unless otherwise agreed in writing between Orient Display and the customer, Orient Display will only replace or repair any of its LCD which is found defective electrically or visually when inspected in accordance with Orient Display general LCD inspection standard . (Copies available on request)
2. No warranty can be granted if any of the precautions state in handling liquid crystal display above has been disregarded. Broken glass, scratches on polarizer mechanical damages as well as defects that are caused accelerated environment tests are excluded from warranty.
3. In returning the LCD/LCM, they must be properly packaged; there should be detailed description of the failures or defect.

13. LCM TEST CRITERIA

1. Objective

The criteria is made for customer and company to check on delivery LCM end product, guarantee the production quality to meet with customer's demand.

2. Range

2.1 Suit for our company's LCD end production.

3. Testing equipment

Function tester、sliding calipers、microscope、visual magnifying glass、ESD arm protector、finger cover、label、high-low temperature experiment case、refrigerator、fixed-voltage power supply (DC) , table lamp and so on.

4. Sampling plan and quote superscript

4.1.1 According to GB/T 2828.1---2003/ISO2859-1:1999, normal check of one sampling plan, general level of inspection II.

Testing item	Sample quantity	AQL judgment
cosmetic	II one time sample	MA=0.4 MI=1.5
scale	N=3	C=0
function	II one time sample	MA=0.4 MI=1.5

4.1.2 GB/T 2828.1---2003/ISO2859-1:1999 check and count the sampling procedure and table one by one.

4.1.3 GB/T 1619.96 Test method of twisting out LCD device.

4.1.4 GB/T 12848.91 General standard of super-out LCD device.

4.1.5 GB2421-89 Basic experience environment of electrical and electronic products

4.1.6 IPC-A-610C Check condition of electrical assemblies.

5. Test condition and basis

5.1 visual: General under the condition of $25\pm 5^{\circ}\text{C}$, $45\pm 20\%\text{RH}$, with enough light ($>300\text{cd}/\text{cm}^2$) , the distance between operator and LCD is 30cm, use the method of reflective to test is normal, the backlight products, must test under the condition of luminance smaller than $100\text{cd}/\text{cm}^2$, and lit up the backlight.

5.2 The test left and right direction is 45° , up and down view angle is $0-45^\circ$ (STN depends on -

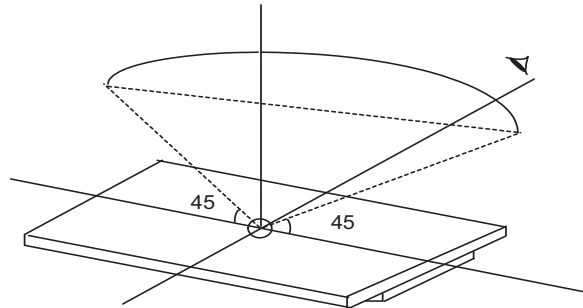

$20-55^\circ$) to have a test, as follows:

5.3 Viewing area definition

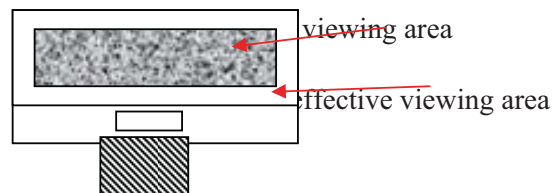

5.4 Naked eye examination (except with assistant of magnifying glass to do defect test) .

5.5 Electricity property

Testing use self-made/professional LCM test installation: contrast with the products file and designed drawing, ask for the display content and parameters accord with the document, and the result in line with the pattern



5.5.1 Testing voltage (V) : Refer to the requirement of test device, customer have no special statement, think the external circuit adjustable, effect controlled in agreed voltage fluctuation (without special agreement, accord to LCD driving voltage at 9V or bellowed control in $\pm 0.3V$, above 9V, at least is LCD driving voltage $\pm 3\%$) , to the products with special voltage demand, assurance display effect through circuit adjust , when necessary made the maximum and minimum receivable samples.

5.5.2 Power consumption of electric current (I) : refer to product document or designed blueprint identify.

6. Defective item and testing criteria

6.1 Scale: To the whole cosmetic scale and which could influence the assemble position , should accord to the drawing, main defect.

6.2 capacity test:

order	item	description	MAJ	MIN	Accept standard
6.2.1	Segment missing	SEG/COM showed line or spot missing caused by line break/bad connection, inner short 	√		reject
6.2.3	No display/no action	Normal connection, no display	√		reject
6.2.4	mistake/abnormal	Accord to common scanner procedure, picture and order inconsistent with requirement	√		reject
6.2.5	Viewing angle mistake	The clearest direction inconsistent with requirement	√		reject
6.2.6	Display dark/light	Normal display the whole ratio too light or dark	√		Over voltage standard, reject
6.2.7	Slow reflect	Reflection of lit or off on part dose not uniform with others.	√		reject
6.2.8	Show more symbol, more lines and rows	due to lack of matching unrighteousness or etched caused alignment or logo when lit display of symbols, row or line.		√	refer to spot/line standard
6.2.9	light/dim segment	On the condition of normal voltage, the display contrast is not uniformed		√	Reject or refer to samples
6.2.10	PI black/white spot	Poor connect in LCD lead to black/white spot in word change procedure		√	Suspended screen, refer to spot/line, others OK
6.2.11	pinhole/white spot	ITO missing lead to picture incomplete when lit up  $d = (X+Y)/2$		√	refer to spot/line standard
6.2.12	word deformed	Mistaken match caused the display width dose not conform to standard, then lead to convex or air leakage: $ a-b \leq 1/4W$ (W is the normal width) 		√	accept $ a-b > 1/4W$, reject
6.2.13	High current	LCM current exceed requirement		√	reject

6.3 LCD visual defect

6.3.1 spot defect (controlled in viewing area, in un-viewing area, OK)

Defective item	average diameter (d)	Accept number	MAJ	MIN
Spot defect (black spot, impurity, pinhole,, contain LC defect)	$d \leq 0.2$	3		√
	$0.2 < d \leq 0.25$	2		
	$0.25 < d \leq 0.30$	1		

6.3.2 Line defect(controlled in viewing area, in un-viewing area, OK)

Defective item	length(L)	width(W)	Accept number	MAJ	MIN
line defect (segment, impurity) 	≤ 5.0	≤ 0.02	3		√
	≤ 3.0	≤ 0.03	3		
	≤ 3.0	≤ 0.05	1		

note: 1.when width is bigger than 0.1, it needs to handle as line defect.

6.3.3 polarizer air bubble (controlled in viewing area, in un-viewing area, OK)

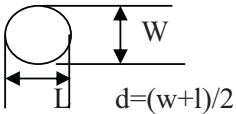
Defective item	average diameter (d)	Accept number	MAJ	MIN
polarizer air bubble、convex point 	$d \leq 0.3$	3		√
	$0.3 < d \leq 0.5$	2		
	$0.5 < d \leq 0.8$	1		

6.3.4 Damaged(LCD edge reveal without mental frame, contain COG,H/S, deduct BL directly)

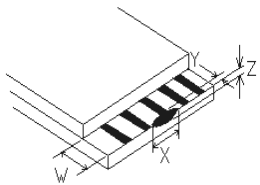
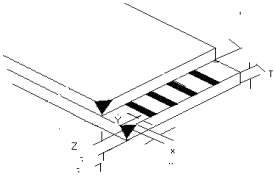
order	item	Permit standard		MAJ	MIN
6.3.4.1	Conductor chips 		(mm)		√
		X	$\leq 1/8L$		
		Y	$\leq 1/3W$		
		Z	$\leq 1/2t$		
		Accept number	2		
When $Y \leq 0.2\text{mm}$, neglect the length of X, un-conductor chips, depend on $X \leq 1/10L$, $Y \leq 1/2W$.					
6.3.4.2	chips(ITO lead position) 		(mm)	MAJ	MIN
		X	Not enter into frit or do not attach the conductor		√
		Y			
		Z	$\leq t$		

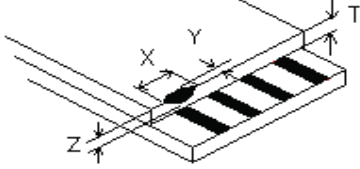
		Accept number	2		
		Seal position refer to 6.3.4.3, do not enter into frame black edge. Chips damage the conducting, refer to 6.3.4.1			
6.3.4.3	interface seal rubber crack (outer crack) 		(mm)	MAJ	MIN
		X	$\leq 1/8 L$		√
		Y	$\leq 1/2 H$		
		Z	$\leq 1/2 t$		
		Accept number	2		
Seal edge rubber inner crack conform to the standard of outer. when the back of stage cracked refer to 6.3.4.1.					
note: t---glass thickness, L---length, H---distance. W—glass stage width					

6.3.5 others

order	item	description	MAJ	MIN	Accept standard
6.3.5.1	coloration/background	One product, different color		√	Reject or refer to limited sample
6.3.5.2	Leak ink(LC)	/	√		reject
6.3.5.3	Without protect film	/		√	reject

6.4 backlight components

order	item	description	MAJ	MIN	Accept standard
6.4.1	Backlight unlit, wrong color	/	√		reject
6.4.2	Color deviation	Lit up, color differ from the sample, or do not match the drawing after testing		√	Refer to sample and drawing
6.4.3	Brightness deviation	Lit up, lightness differ from the sample, or do not match the drawing after testing, or over the sample range of $\pm 30\%$.		√	Refer to sample and drawing
6.4.4	LED uneven	Lit up, brightness uneven, exceed the drawing specification.		√	Refer to sample and drawing
6.4.5	Spot/line segment	There are tainted, segment when lit up.		√	Refer to 6.3.1/6.3.2

6.5 Mental frame

order	item	description	MAJ	MIN	Accept standard
6.5.1	material/surface	Mental frame/surface approach inconsistent with specification.	√		reject
6.5.2	Twist un-quality/without twisting	Twist method/direction default,	√		reject
6.5.3	oxidation, paint stripping, discoloration, dent ,segment	The surface of the mental frame dose not appear oxidation, front surface paint stripping and segment to bottom \leq 0.8mm, exceed 3 point, length \leq 5.0mm, width \leq 0.05mm line defect exceed 2 point, positive dent, bubble and side surface have paint stripping and segment to bottom \leq 1.0mm exceed 3 point, width \leq 0.05mm line defect exceed 3 point.		√	reject
6.5.4	prick	Prick is too long, enter into viewing area		√	reject

6.6 PCB/COB part

order	item	description	MAJ	MIN	Accept standard
6.6.1	Seal rubber defect	<ol style="list-style-type: none"> 1. COB inner round white remark line have PAD out reveal.. 2. height exceed the document/drawing specification. 3. COB seal rubber should in white remark, the largest out scale can not exceed remark radius 2MM 4. COB surface has clear lien assemble mark, some even through the pinhole. 5. COB surface pinhole diameter over 0.25mm or have tainted.. 		√	reject
6.6.2	PCB cosmetic defect	<ol style="list-style-type: none"> 1. PCB golden figure surface can not have oxidation, dirt. 2. PCB can not appear bubble caused by reflow. 3. PCB green oil drop /segment lead to leak copper. <p>Use mending, circuit diameterψ can not over 1.3mm, other diameterψ can not over 2.6mm, total less than 10 point. otherwise reject.</p>		√	reject

6.6.3	Components mistake	<ol style="list-style-type: none"> 1. PCB components inconsistent with drawing. Find wrong pitch, more or less pitch, polar reverse (LCD voltage side circuit/BL current limit resistance modify, only if customer have special require, otherwise do not control) 2. The JUMP of PCB shot need refer to the structure picture, appear more or less soldering. 3. customer have special require on the component, mode specification and supplier should conform to technique demand. Otherwise reject. 	√	√	reject
-------	--------------------	--	---	---	--------

6.7 SMT part (vague parts refer to IPC-A-610C)

Order	Item	Description	MAJ	MIN	Accept standard
6.7.1	Soldering defect	Cold solder, fake solder, missing solder, crack, tin un-dissolved		√	reject
6.7.2	Solder ball/bridge	Solder ball/bridge drop lead to spot short.		√	reject
6.7.3	DIP parts	DIP parts, keypad, connection appear flowing and tilted.		√	reject
6.7.4	Spot shape	Inner dent, can not form to cover solder or less solder, otherwise reject		√	reject
6.7.5	Component out reveal	After cutting, just left 0.5mm~2mm,can not damage solder surface and covered the component foot. Otherwise reject.		√	reject
6.7.6	Cosmetic defect	Solder residues appear tawny or coke black. PCB solder spot remained white mist residues after clean.		√	reject

6.8 Thermal press part (contain H/S, FPC)

Order	item	description	MAJ	MIN	Accept standard
6.8.1	Model specifications do not match		√		reject
6.8.2	Scale/position	Material scale must in the drawing specification range, the contact area of dielectric material and the body (ITO, PDA) should be above 1/2, and the dislocation must control in specification		√	Accept

6.8.3	Thermal press dirt	Thermal area tainted can not lead to short, OK, in through position, dirt area is smaller than 50%, OK.		√	accept
6.8.4	creases			√	Refer to limited sample

6.9 connection and other parts

order	item	description	MAJ	MIN	Accept standard
6.9.1	Specification un-matched	Connection and other components do not conform to drawing requirement	√		reject
6.9.2	Position and order	Solder position should consistent with the drawing .		√	reject
6.9.3	cosmetic	1. the body of our connect component and the PIN foot have solder-helping. 2. PIN connection PIN deformation bigger than PIN width 1/2.		√	reject

6.10 General visual

order	item	description	MAJ	MIN	Accept standard
6.10.1	Connect material	FPC golden figure or H/S,FFC out part of PIN leak copper or material, have damaged. FPC,FFC,COF,H/S connected material curved (except for original) . FPC、PCB golden figure bigger than 1PIN width. FPC/FFC material segment, crease exceed the specification.		√	reject
6.10.2	Protect defect	Protect film do not cover circuit totally (如 H/S, FFC, FPC) or not contact with interface, or add on PIN outer part.		√	reject
6.10.3	Visual dirty	The surface of end products have dirt, rubber, PCB/COB un-welding area has solder ball. The defective remark or label do not clean.		√	reject
6.10.4	Assembly black spot	Add backlight, taint and black spot		√	Refer to 6.3.1
6.10.5	Product remark	Model defer from approved remark and technique requirement、 position, vague and leak.		√	reject
6.10.6	Inner product	Packing inconsistent with requirement,		√	reject

	packing	segment short, wrong amount. And inconsistent with shipment remark/ order demand.			
--	---------	---	--	--	--

7. Reality test

Note: If customer have requirement, please put forward on the item development. (high/low

Test item	Condition	Time(hrs)	Accept standard
high temp storage	80°C	120	
high temperature operating	70°C	120	
low temperature storage	-30°C	120	Before and after test, function and cosmetic is qualified.
low temperature operating	-20°C	120	
temperature& humidity test	40°C/ 90%RH	120	
temperature shock	-20°C ← 25°C → +70°C (30 min ← 5 min → 30min)	10 cycles	

temperature storage and experiment, the temperature refer to specific requirement) , ±5°C deviation could be accept.

8. Packing

- 8.1 Product design must meet the requirement of packing design and check on delivery. Besides the product name, specification, model, quantity and date on the label, the quality chapter is necessary after checked by QA. Incomplete or mistake, is not qualified.
- 8.2 When the safety of the packing (earthquake, moisture-proof, anti-static, anti-squeezed) exist problem, not qualified.
- 8.3 When customer's special requirement is confirmed and accepted by interior, carry it out and check on delivery.
- 8.4 Environment protected and unprotected products must have obvious distinguished remark. The present remark adopts "RoHS". If customer have special requirement, use the appointed remark or label.

9. Others

- 9.1 No-provision or compromised item, depend on two side agreement and limited prototype.