



TE Connectivity

CUSTOMER DATA

PART NO.

1432782-1

SHT. 1
OF 2

DRAWN E.SIMPSON	APPROVAL B. TOEPFER	DATE FIRST_DRAWN 05-26-05	SCALE 1:1
--------------------	------------------------	------------------------------	--------------

CUSTOMER TYCO_ELECTRONICS_STANDARD

TOLERANCE UNLESS SPECIFIED OTHERWISE	0.X = +/-
	0.XX = +/-
	0.XXX = +/-
	ANGLES = +/-

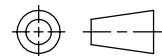

DO NOT SCALE THIS DRAWING

CHANGES

REV.	DATE	CO	APP.
D	03NOV2017	ECO-17-003787	B.T.
D1	29DEC2022	ECN-22-181733	B.K.

NOT TO BE USED IN AUTOMOTIVE APPLICATIONS OR APPLICATIONS REQUIRING PPAP AND/OR IMDS DOCUMENTATION

ELECTRICAL CHARACTERISTICS: (ALL DATA APPLIES @ 23°C UNLESS OTHERWISE SPECIFIED)COIL DATA:

NOMINAL VOLTAGE:	12 VDC
OPERATE VOLTAGE:	7.8 VDC MAXIMUM
RELEASE VOLTAGE:	1.2 VDC MINIMUM
COIL RESISTANCE:	90 OHMS +/- 10%
OPERATE TIME:	8 mSEC. MAXIMUM EXCLUDING BOUNCE
RELEASE TIME:	5 mSEC. MAXIMUM EXCLUDING BOUNCE
TEMPERATURE RANGE:	OPERATING -40°C TO +85°C

CONTACT DATA:

CONTACT ARRANGEMENT:	1 FORM A (SPST)
CONTACT MATERIAL:	AgSnO (SILVER TIN-OXIDE)
CONTACT MILLIVOLT DROP:	200mv @ 35A (AFTER SWITCHING)
MAXIMUM MAKE CURRENT:	90A (LAMP) @ 16 VDC
MAXIMUM BREAK CURRENT:	40A @ 16 VDC RESISTIVE
MAXIMUM CONTINUOUS CURRENT:	40A @ 23°C , 35A @ 85°C
INITIAL BREAKDOWN CURRENT	500V RMS CONTACTS TO COIL

OBSOLETE

EXPECTED LIFE:	100,000 OPERATIONS, 40 A, 14 VDC RESISTIVE
----------------	--

MECHANICAL CHARACTERISTICS:

EXPECTED LIFE:	10 MILLION OPERATIONS, NO CONTACT LOAD
TERMINALS	COPPER, UNPLATED



TE Connectivity

CUSTOMER DATA

PART NO.
1432782-1

SHT. 2
OF 2

DRAWN E.SIMPSON	APPROVAL B. TOEPFER	DATE FIRST_DRAWN 05-26-05	SCALE 1:1
--------------------	------------------------	------------------------------	--------------

CUSTOMER
TYCO_ELECTRONICS_STANDARD

TOLERANCE 0.X = +/-
 UNLESS 0.XX = +/-
 SPECIFIED 0.XXX = +/-
 OTHERWISE ANGLES = +/-

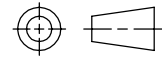

REV D1

DO NOT SCALE THIS DRAWING

MILLIMETERS

MARKING TO INCLUDE:

TYCO ELECTRONICS NAME, TYCO ELECTRONICS PART NUMBER, SCHEMATIC, COIL VOLTAGE, COUNTRY OF ORIGIN, AND DATE CODE

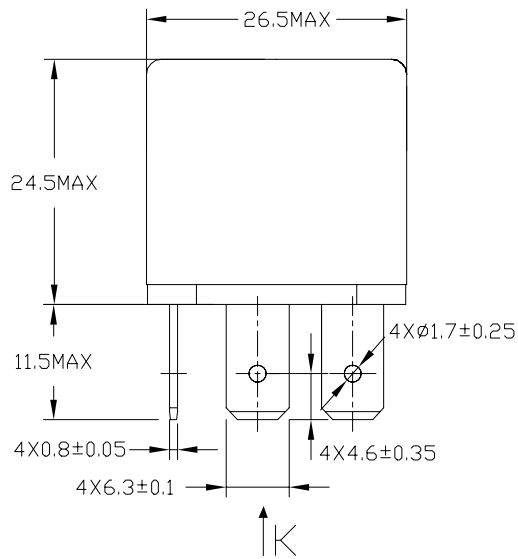

K Aspect

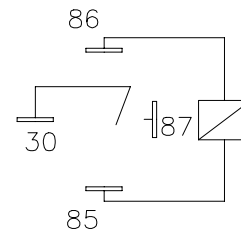
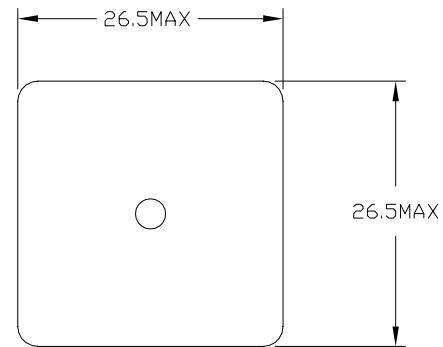
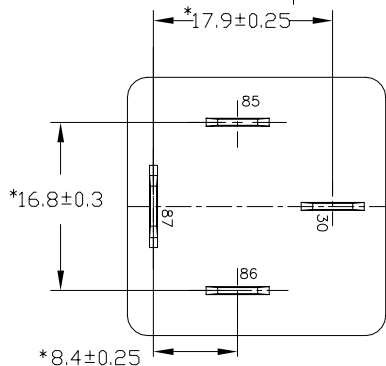

Schematic Drawing
(Bottom views)

* TERMINAL LOCATIONS APPLY AT THE BASE OF THE TERMINALS

OBSOLETE

NOT TO BE USED IN AUTOMOTIVE APPLICATIONS OR APPLICATIONS REQUIRING PPAP AND/OR IMDS DOCUMENTATION