

RECOMMENDED PCB LAYOUT

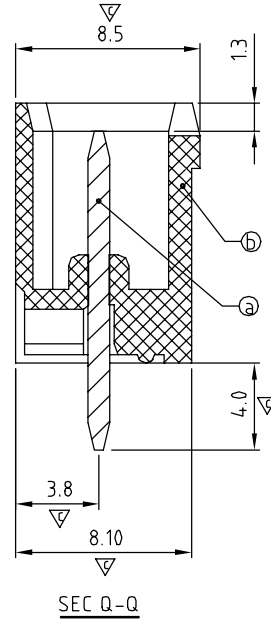

SEC Q-Q

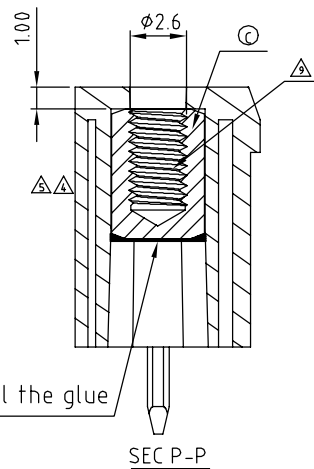

SEC P-P

Fill the glue

DIMENSION

A	(N+2)×5.08
B	(N-1)×5.08

N= NUMBER OF CONCATS

Poles	Tolerance
2P-6P	±0.15
7P-12P	±0.20
13P-18P	±0.30
19P-24P	±0.40

SIGN	DATE	DESCRIPTION	APPROVER
△	8/16'06	Added VDE and TUV standard	Steady
△	8/16'06	Current rating (cULus) changed from 10A to 20A	Steady
△	1/20'07	Soldering temperature changed from 245° to 250°	Tony
△	5/28'08	Body flange is changed	Marvin
△	2009.7.6	The design is changed from the round hole to hexagonal hole	Jacke
△	2009.10.22	The material is changed from Brass to Copper	Jacke
△	2009.10.22	Remove the CSA certification	Jacke
△	2010.03.22	The design is changed	Jacke
△	11/21'11	Flange nut is changed	ChenMing

THIS IS CAD DRAWING, DO NOT REVISE MANUALLY!!!

Material:

- Item A Male contact pin: Copper Tin plated
- Item B Terminal(housing): Thermoplastic (UL94V-0)
- Item C With flange nut: Brass ,M2.5

- Electrical: cULus /VDE /TUV
- Voltage rating: 300V/300V/300V
 - Current rating: 20A/20A/20A
 - Withstanding Voltage: 1.6 KV/2.5KV/2.5KV
 - Operating temperature: -40°C to +115°C
 - Soldering temperature: 250°C±10°C/5 Sec
 - Safety Approval:
 - Critical dimension: ▽
 - Part No.:

OQ xx 5 5 x 0 xxxx G

No. OF POLES
02: 2 POLES
:
24: 24 POLES

COLOR
0 Black (RAL9005)
2 Red (RAL3001/D)
3 Orange(RAL2011/P)
4 Yellow(RAL1018/A)
5 Green(RAL6018/T)
6 Blue (RAL5015/A)
8 Grey(RAL7035/D)

G: Pb<40000ppm
0000: "@ " Logo (Standard)
000A: "ANYTEK" Mark
00PM: "PM" Mark
Any special item by customer request.
please contact sales department.

ANYTEK				CUSTOMER COPY			
ALL RIGHTS RESERVED. REPRODUCTION OR ISSUE TO THIRD PARTIES IN ANY FORM WHATSOEVER IS NOT PERMITTED WITHOUT WRITTEN AUTHORITY FROM THE PROPRIETOR. PROPERTY OF ANYTEK TECHNOLOGY CO., LTD							
TITLE		OQ 5.08mm 180° W/Flange Series 2p-24p					
PART NO.		OQxx55x0xxxxG			DWG NO.		80Q0705
APPROVED		CHECKED	DESIGNED	DRAWN	CUST NO.		Tolerance
				ChenMing 2011.11.22			X. ±0.50 X.X ±0.30 X.XX ±0.10 X° ±1°
				SHEET: 01/01		UNIT: mm SCALE: NONE REV.: L	