

SECTION A-A

SECTION C-C

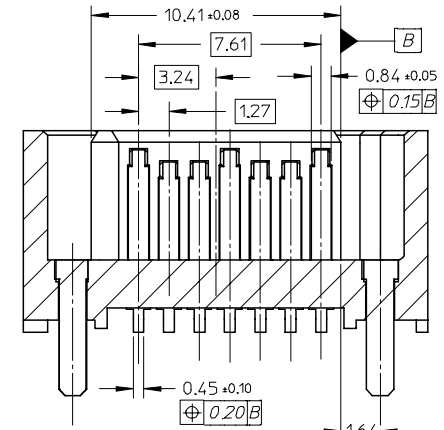

SECTION B-B

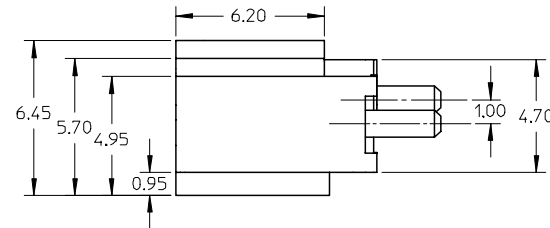
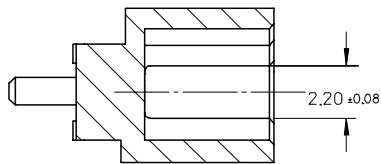
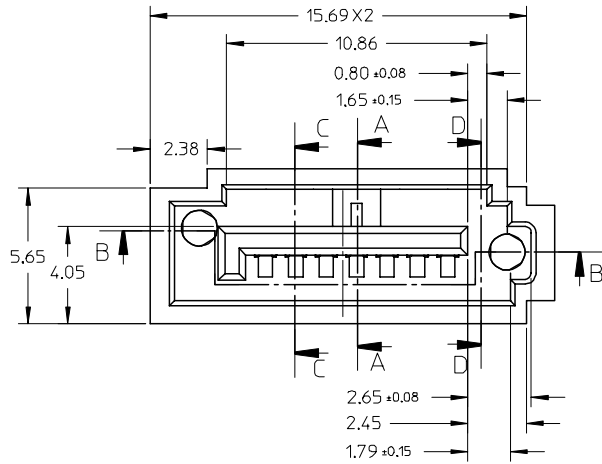

SECTION D-D

EC NO: SH2005-0037 DRWN:GRMA 2004/10/25 CHKD: 2004/10/26 APPR: YTYAP 2004/10/28	QUALITY SYMBOLS ▽ = 0 ▽ = 0	GENERAL TOLERANCES (UNLESS SPECIFIED)		SCALE 5:1	DESIGN UNITS METRIC	THIRD ANGLE PROJECTION	REVISE ON CAD ONLY
		mm	INCH	DIMENSION STYLE MM ONLY		TITLE HIGH SPEED CONNECTOR 1.27MM PITCH VERTICLE SMT SOLDER TAIL	
REV	DESCRIPTION	4 PLACES	± ---	± ---	DRAWN BY GRATE MA	DATE 2004/02/02	MATERIAL NO. SEE SHEET 2
		3 PLACES	± ---	± ---	CHECKED BY YAJUN	DATE 2004/02/02	
		2 PLACES	± 0.15	± ---	APPROVED BY SAM	DATE 2004/02/02	SHEET NO. 1 OF 2
		1 PLACE	± 0.25	± ---	THIS DRAWING CONTAINS INFORMATION THAT IS PROPRIETARY TO MOLEX INCORPORATED AND SHOULD NOT BE USED WITHOUT WRITTEN PERMISSION		
		ANGULAR ± 1 °		DRAFT WHERE APPLICABLE		MUST REMAIN WITHIN DIMENSIONS	

