



5W Low Cost Adapter Series



Features

- Double Insulated
- Efficiency Level VI Compliance
- Small Package Size
- Low Leakage Current
- Low Cost
- Class B EMI

Applications

- MPEG Players
- PDAs
- Personal Electronics
- Digital Cameras

Safety Approvals

- UL/cUL 60950-1/UL/cUL 62368-1¹
- CE²
- IEC60950-1/IEC62368-1²

Mechanical Characteristics – US Models

- Length: 66.5mm (2.62in)
- Width: 28.0mm (1.10in)
- Height: 39.0mm (1.54in)
- Weight: 85g (3oz)

Mechanical Characteristics – EU Models

- Length: 66.5mm (2.62in)
- Width: 28.0mm (1.10in)
- Height: 54.0mm (2.13in)
- Weight: 155.92g (5.5oz) Ref

Mechanical Characteristics – UK Models

- Length: 66.5mm (2.62in)
- Width: 48.0mm (1.89in)
- Height: 43.0mm (1.69in)
- Weight: 184.27g (6.5oz) Ref

Output Specifications

| Model | Prong Style | DC Output Voltage | Load | | Ripple ³ P-P (max.) | Regulation Line & Load | Output Cable |
|-------------------------------|-------------|-------------------|------|------|--------------------------------|------------------------|--------------|
| | | | Min. | Max. | | | |
| PSAC05A-050L6-R | US | 5V | 0A | 1A | 150mV | ±5% | Barrel |
| PSAC05A-050L6M-R | US | 5V | 0A | 1A | 150mV | ±5% | Micro-b |
| PSAC05A-050L6B-R ⁴ | US | 5V | 0A | 1A | 150mV | ±5% | Mini-b |
| PSAC05E-050L6-R ⁴ | EU | 5V | 0A | 1A | 150mV | ±5% | Barrel |
| PSAC05E-050L6M-R ⁴ | EU | 5V | 0A | 1A | 150mV | ±5% | Micro-b |
| PSAC05K-050L6-R ⁴ | UK | 5V | 0A | 1A | 150mV | ±5% | Barrel |
| PSAC05K-050L6M-R ⁴ | UK | 5V | 0A | 1A | 150mV | ±5% | Micro-b |

Notes:

1. US models only
2. EU & UK models only
3. Measurement made with an oscilloscope with 20MHz Bandwidth. Output bypassed at connector with a 0.1uF ceramic capacitor and a 10uF electrolytic capacitor (Low ESR)
4. Special order MOQ

Input:

AC Input Voltage Rating
100 to 240V AC

AC Input Voltage Range
90 to 264V AC

AC Input Frequency
47 to 63Hz

Input Current
0.15A (RMS) maximum

Leakage Current
250uA maximum

Inrush Current
40A @115Vac/60Hz & Max load
60A @230Vac/50Hz & Max load
(Cold start at ambient 25°C)

Input Power Saving²
<75mW@115VAC/230VAC No Load

Output:**Efficiency³**

DOE Level VI
Ecodesign Directive 2009/125/EC (EU
2019/1782)

Dielectric Withstand (Hi-pot) Test

Primary to Secondary: 3000V AC for 1
min., 10mA

Short-Circuit Protection

Output can be shorted permanently without
damage

Over-Voltage Protection

7.5V DC maximum

Over-Current Protection

2A maximum

Environmental:**Temperature**

| | |
|---------------|--------------|
| Operation | 0 to +40°C |
| Non-operation | -20 to +70°C |
| Humidity | 0 to 90% |

Emissions

Complies with FCC Class B
Complies with EN55032 Class B

Immunity

EN 61000-4-2 Level 4, Contact ±8kV. Air ±
15kV
EN 61000-4-5 Level 3, 1kV line to neutral,
Criteria B

Notes:

1. The characteristics defined are at ambient temperature of 25°C unless otherwise specified
2. No load after 15 minutes warm-up
3. Efficiency is measured after 30minutes burn-in

Dimension Diagram Unit: mm

PSAC05E-050L6-R

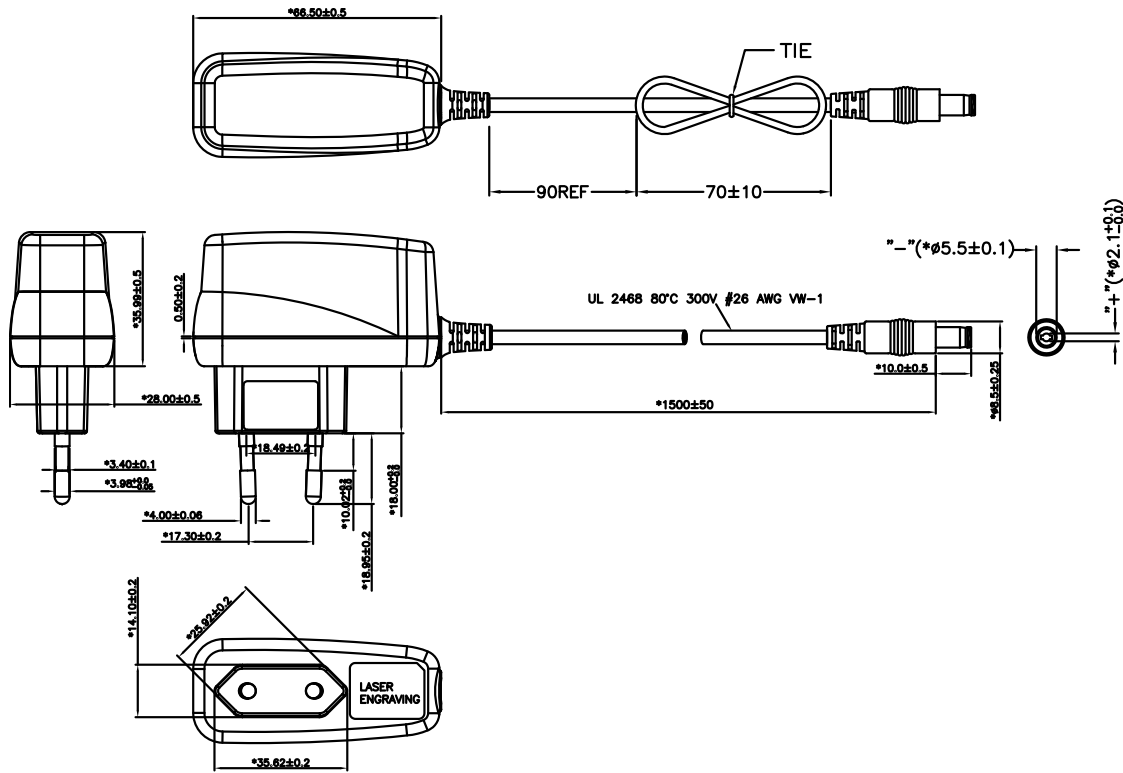

Dimension Diagram Unit: mm

PSAC05E-050L6M-R

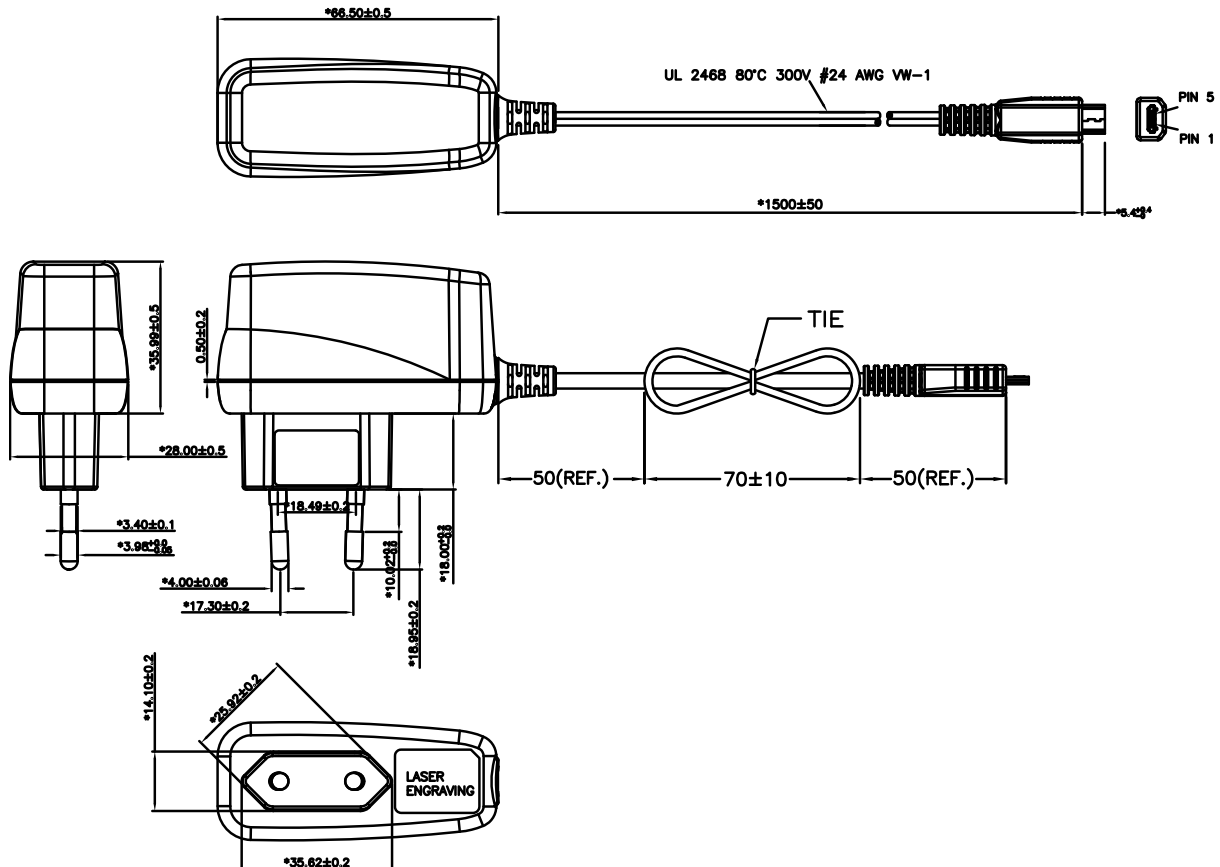

Dimension Diagram Unit: mm

PSAC05K-050L6-R

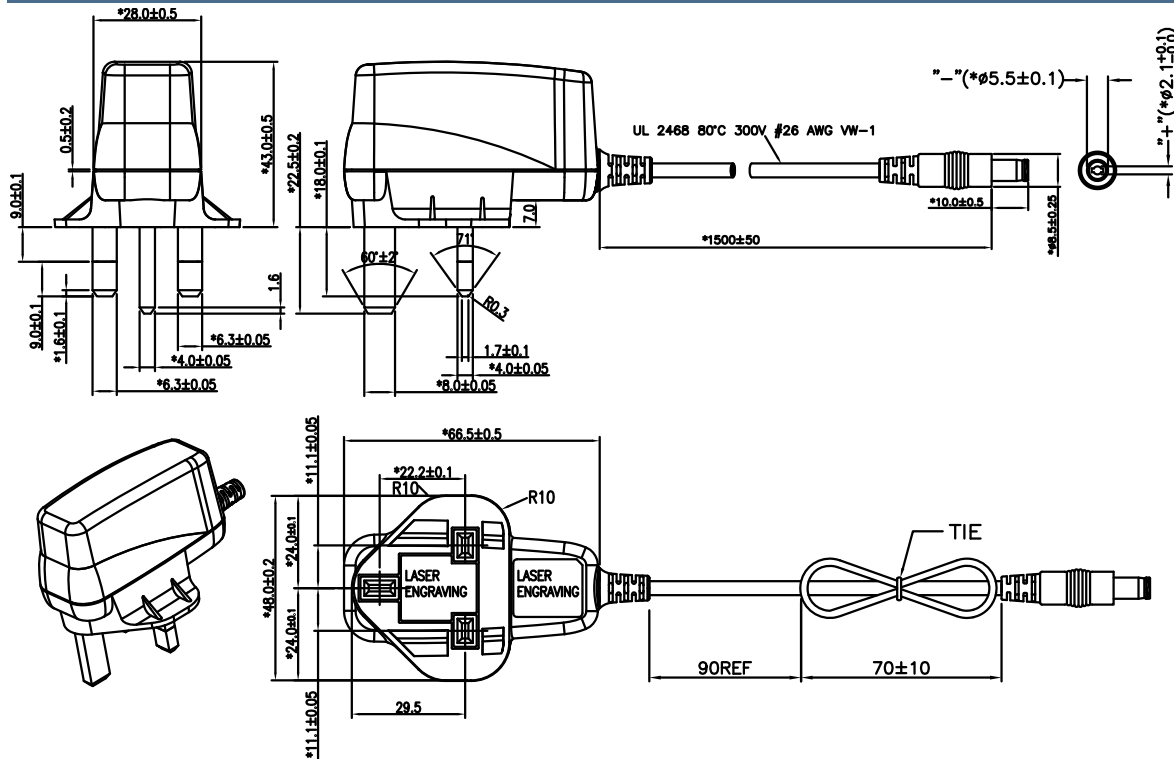

Dimension Diagram Unit: mm

PSAC05K-050L6M-R

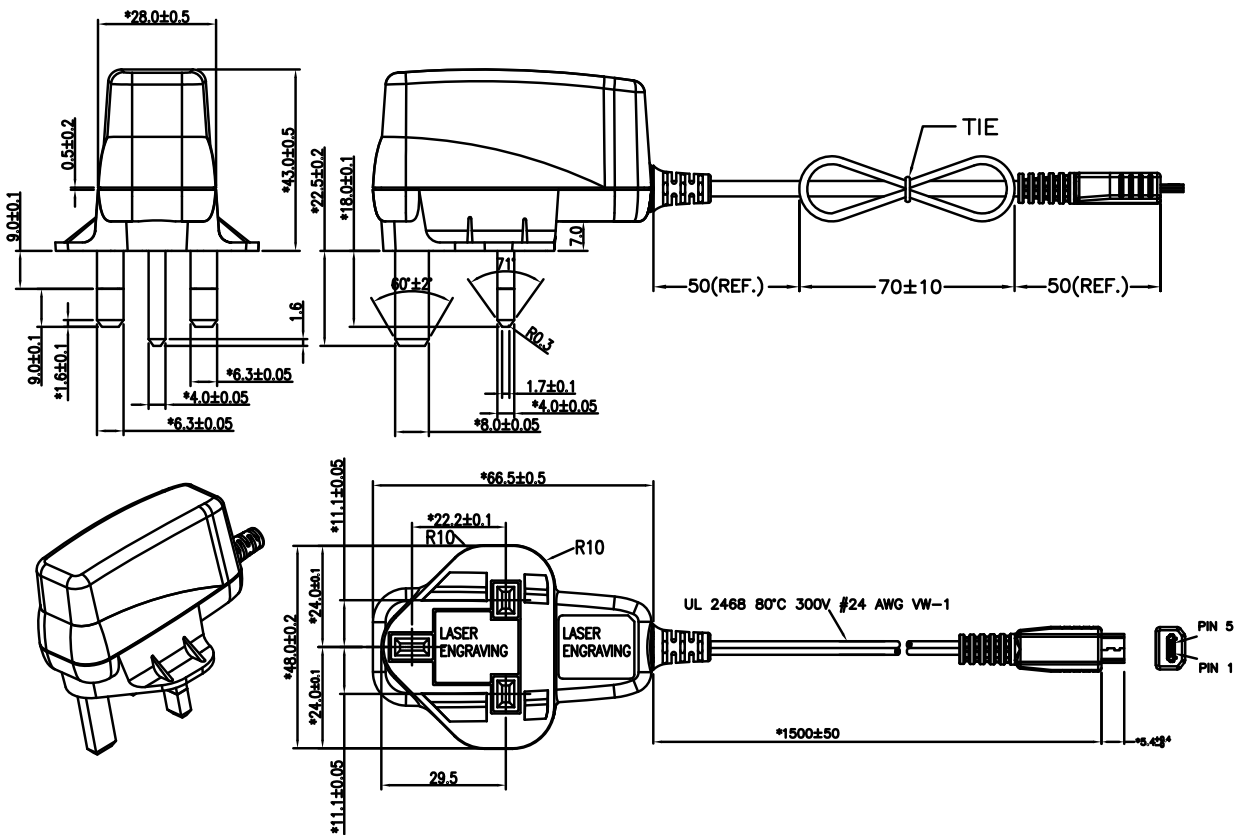

**Supplier's Declaration of Conformity
47 CFR § 2.1077 Compliance Information**

**PSAC05A-050L6-R
PSAC05A-050L6M-R
PSAC05A-050L6B-R**

Phihong USA Corporation
47800 Fremont Boulevard
Fremont, CA 94538
Telephone: (510) 445-0100
www.phihong.com

NOTE: This model has/The models in this product series have been tested and found to comply with the limits for a Class B digital device, pursuant to part 15 of the FCC Rules. These limits are designed to provide reasonable protection against harmful interference in a residential installation. This equipment generates, uses and can radiate radio frequency energy and, if not installed and used in accordance with the instructions, may cause harmful interference to radio communications. However, there is no guarantee that interference will not occur in a particular installation. If this equipment does cause harmful interference to radio or television reception, which can be determined by turning the equipment off and on, the user is encouraged to try to correct the interference by one or more of the following measures:

- Reorient or relocate the receiving antenna.
- Increase the separation between the equipment and receiver.
- Connect the equipment into an outlet on a circuit different from that to which the receiver is connected.
- Consult the dealer or an experienced radio/TV technician for help.

Changes or modifications to equipment not expressly approved by PHIHONG could void the user's authority to operate the equipment.