

Three-Phase Sensorless Fan Driver

Not for New Design

These parts are in production but have been determined to be NOT FOR NEW DESIGN. This classification indicates that sale of this device is currently restricted to existing customer applications. The device should not be purchased for new design applications because obsolescence in the near future is probable. Samples are no longer available.

Date of status change: September 3, 2018

Recommended Substitutions:

For existing customer transition, and for new customers or new applications, contact factory.

NOTE: For detailed information on purchasing options, contact your local Allegro field applications engineer or sales representative.

Allegro MicroSystems reserves the right to make, from time to time, revisions to the anticipated product life cycle plan for a product to accommodate changes in production capabilities, alternative product availabilities, or market demand. The information included herein is believed to be accurate and reliable. However, Allegro MicroSystems assumes no responsibility for its use; nor for any infringements of patents or other rights of third parties which may result from its use.

Three-Phase Sensorless Fan Driver

FEATURES AND BENEFITS

- Sensorless (no Hall sensors required)
- Soft switching for reduced audible noise
- Minimal external components
- PWM speed input
- FG speed output
- Low power standby mode
- Lock detection
- Optional overcurrent protection
- Variant A automotive qualified to AEC-Q100 Grade 2

PACKAGE:

16-pin TSSOP with exposed thermal pad (suffix LP)

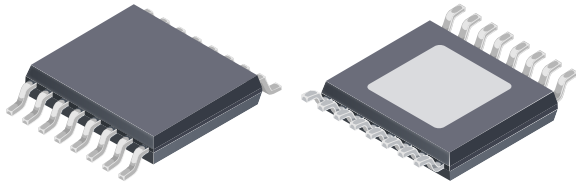

Not to scale

DESCRIPTION

The A4941 three-phase motor driver incorporates BEMF sensing to eliminate the requirement for Hall sensors in fan applications.

A pulse wave modulated (PWM) input is provided to control motor speed, allowing system cost savings by eliminating external variable power supply. PWM input can also be used as an on/off switch to disable motor operation and place the IC into a low power standby mode.

The A4941 is provided in a 16-pin TSSOP package (suffix LP) with an exposed thermal pad. It is lead (Pb) free, with 100% matte tin leadframe plating.

Functional Block Diagram

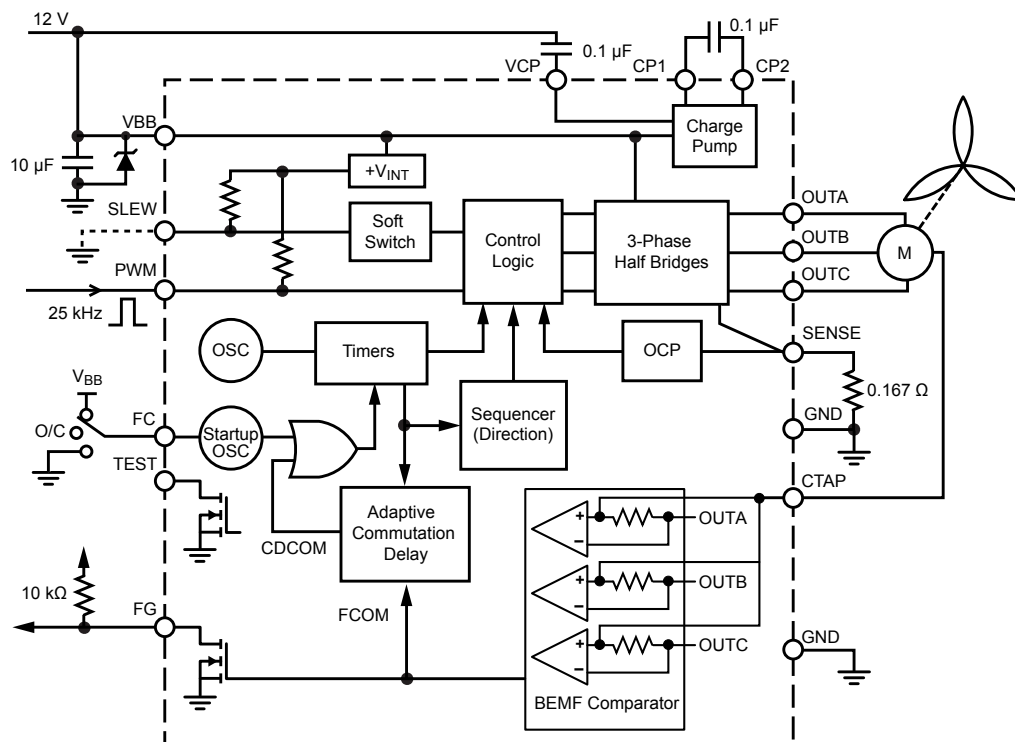

SELECTION GUIDE

Part Number	Application	Packing
A4941GLPTR-T	Commerical/Industrial	4000 pieces per 13-in. reel
A4941GLPTR-A-T	Automotive	4000 pieces per 13-in. reel

ABSOLUTE MAXIMUM RATINGS

Characteristic	Symbol	Notes	Rating	Unit
Supply Voltage	V_{BB}		20	V
Logic Input Voltage Range	V_{IN}	PWM, SLEW	-0.3 to 5.5	V
		FC	-0.3 to V_{BB}	V
Logic Output Voltage	V_{OUT}	FG	V_{BB}	V
Output Current	I_{OUT}	Peak (startup and lock rotor)	1.25	A
		rms, duty cycle = 100%	900	mA
Operating Ambient Temperature	T_A	G temperature range	-40 to 105	°C
Maximum Junction Temperature	$T_J(\text{max})$		150	°C
Storage Temperature	T_{stg}		-55 to 150	°C

RECOMMENDED OPERATING CONDITIONS

Characteristic	Symbol	Conditions	Min.	Typ.	Max.	Unit
Supply Voltage	V_{BB}		5	-	16	V
Output Current	I_{OUT}	Peak (startup and lock rotor)	-	-	1	A
		Run current	-	<500	-	mA

THERMAL CHARACTERISTICS: May require derating at maximum conditions

Characteristic	Symbol	Test Conditions*	Value	Unit
Package Thermal Resistance	$R_{\theta JA}$	On 4-layer PCB based on JEDEC standard	34	°C/W
		On 2-layer PCB with 1 in. ² of copper area each side	52	°C/W

*Additional thermal information available on the Allegro website

Pinout Diagram

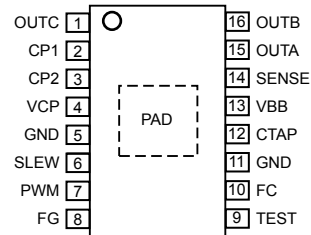

Terminal List Table

Name	Number	Function
CP1	2	Charge pump
CP2	3	Charge pump
CTAP	12	Motor terminal center tap
FC	10	Logic input
FG	8	Speed output signal
GND	5, 11	Ground
OUTA	15	Motor terminal A
OUTB	16	Motor terminal B
OUTC	1	Motor terminal C
PWM	7	Logic input
SENSE	14	Sense resistor connection
SLEW	6	Logic input
TEST	9	Test use only, leave open circuit
VBB	13	Input supply
VCP	4	Charge pump

ELECTRICAL CHARACTERISTICS: Valid at $T_J = -40$ to 105°C , $V_{BB} = 5$ to 16 V^* , unless otherwise noted

Characteristics	Symbol	Test Conditions	Min.	Typ.	Max.	Unit
VBB Supply Current	I_{BB}		–	2.5	5	mA
	I_{BBST}	Standby mode, PWM = 0 V, SLEW = FC = 0/C	–	25	50	μA
Total Driver $R_{DS(on)}$ (Sink + Source)	$R_{DS(on)}$	$I = 800\text{ mA}$, $T_J = 25^\circ\text{C}$	–	800	1200	m Ω
Overcurrent Threshold	V_{OCL}		180	200	220	mV
PWM Low Level	V_{IL}		–	–	0.8	V
PWM High Level	V_{IH}		2	–	–	V
Input Hysteresis	V_{HYS}		–	300	600	mV
Logic Input Current	I_{IN}	PWM, $V_{IN} = 0\text{ V}$	–25	–15	–5	μA
		SLEW, $V_{IN} = 0\text{ V}$	–70	–50	–20	μA
		FC, $V_{IN} = 0\text{ V}$	–30	–15	–5	μA
Output Saturation Voltage	V_{SAT}	$I = 5\text{ mA}$	–	–	0.3	V
FG Output Leakage	I_{FG}	$V = 16\text{ V}$	–	–	1	μA
PROTECTION CIRCUITRY						
Lock Protection	t_{on}		1.6	2	2.4	s
	t_{off}		4	5	6	s
Thermal Shutdown Temperature	T_{JTSD}	Temperature increasing	150	165	180	$^\circ\text{C}$
Thermal Shutdown Hysteresis	T_{JHYS}	Recovery = $T_{JTSD} - \Delta T_J$	–	15	–	$^\circ\text{C}$
VBB Undervoltage Lockout (UVLO)	V_{UVLO}	V_{BB} rising	–	4.3	4.7	V

*For the A4941GLPTR-T, the electrical test is performed at 12 V only and characterized across the voltage range.

FUNCTIONAL DESCRIPTION

The driver system is a three-phase, BEMF sensing motor controller and driver. Commutation is controlled by a proprietary BEMF sensing technique.

The motor drive system consists of three half bridge NMOS outputs, BEMF sensing circuits, adaptive commutation control, and state sequencer. The sequencer determines which output devices are active. The BEMF sensing circuits and adaptive commutation circuits determine when the state sequencer advances to the next state.

A complete self-contained BEMF sensing commutation scheme is provided. The three half-bridge outputs are controlled by a state machine with six possible states, shown in figure 1. Motor BEMF is sensed at the tri-stated output for each state.

BEMF sensing motor commutation relies on the accurate comparison of the voltage on the tri-stated output to the voltage at the center tap of the motor. The BEMF zero crossing, the point where the tri-stated motor winding voltage crosses the center tap voltage, is used as a positional reference. The zero crossing occurs roughly halfway through one commutation cycle.

Adaptive commutation circuitry and programmable timers determine the optimal commutation points with minimal external components. The major blocks within this system are: the BEMF zero crossing detector, Commutation Delay timer, and the Blank timer.

BEMF ZERO CROSS DETECTION

BEMF zero crossings are detected by comparing the voltage at the tri-stated motor winding to the voltage at the motor center tap. Zero crossings are indicated by the FCOM signal, which goes high at each valid zero crossing and low at the beginning of the next commutation. In each state, the BEMF detector looks for the first correct polarity zero crossing and latches it until the next state. This latching action, along with precise comparator hysteresis, makes for a robust sensing system. At the beginning of each commutation event, the BEMF detectors are inhibited for a period of time set by the Blank timer. This is done so that commutation transients do not disturb the BEMF sensing system.

COMMUTATION EVENT

See figure 1 for timing relationships. The commutation sequence is started by a CDCOM pulse or a valid XCOM at startup. After

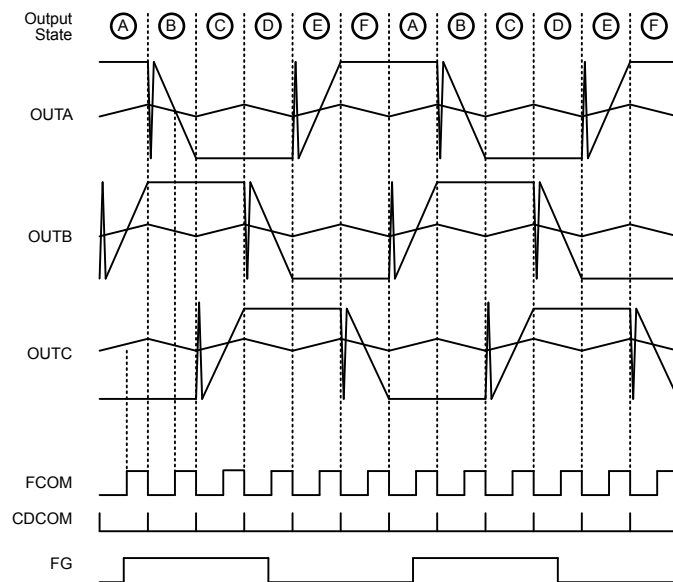

Figure 1. Motor Terminal Output States

the commutation delay period, a CDCOM is asserted, starting the Blank timer. The Blank signal disables the BEMF detector so the comparator is not active during the commutation transients. The next zero crossing, detected on the tri-stated output, causes FCOM to go high. This triggers the Commutation Delay timer and the sequence repeats.

CTAP

Connection pin for motor center-tap if available. If not available (such as with delta type motors), CTAP can be left open and the null point will be generated internally.

STARTUP

At startup, commutations are provided by an onboard oscillator. These commutations are part of the startup scheme, to step the motor to generate BEMF until legitimate BEMF zero crossings are detected and normal BEMF sensing commutation is achieved. Until an appropriate number of FCOM pulses are achieved (96), 100% PWM will be applied to the motor windings.

STANDBY MODE

Driving PWM low for 500 μ s causes the IC to enter a low power standby mode.

LOCK DETECT

Valid FCOM signals must be detected to ensure the motor is not stalled. If a valid FG is not detected for 2 s, the outputs will be disabled for 5 s before an auto-restart is attempted.

FG OUTPUT

The FG output provides fan speed information to the system. FG is an open drain output.

PWM INPUT

The duty cycle applied to the PWM pin is translated directly to an average duty cycle applied across the motor windings to control speed.

- For voltage controlled applications, where V_{BB} controls the speed, PWM can be left open circuit. PWM is internally pulled-up to logic high level.

- PWM also can be used as a control input to start and stop the motor.
- For PWM applications, input frequencies in the range 15 to 30 kHz are applied directly to the motor windings. If the PWM duty cycle is very small, then the IC will apply a minimum pulse width of typically 6 μ s. This minimum pulse width effects the minimum speed. As a result of having a minimum pulse width, the IC can startup and operate down to very short duty cycles.

SLEW INPUT

Enables or disables soft switching by connection as follows:

SLEW Pin Connection	Soft Start Status
GND	Enabled
Open	Disabled

FC INPUT

This is the logic input to set force commutation time at startup, by connection as follows:

FC Pin Connection	Startup Commutation Time (ms)
GND	100
VBB	50
Open	200

OVERCURRENT PROTECTION

If needed, a sense resistor can be installed to limit current. (See Applications Information section for more details.) The current limit trip point would be set by:

$$I_{OCL} = 200 \text{ mV} / R_S$$

When the trip point is reached, if the threshold voltage, V_{OCL} , is exceeded, the drivers will be disabled for 25 μ s.

INPUT/OUTPUT STRUCTURES

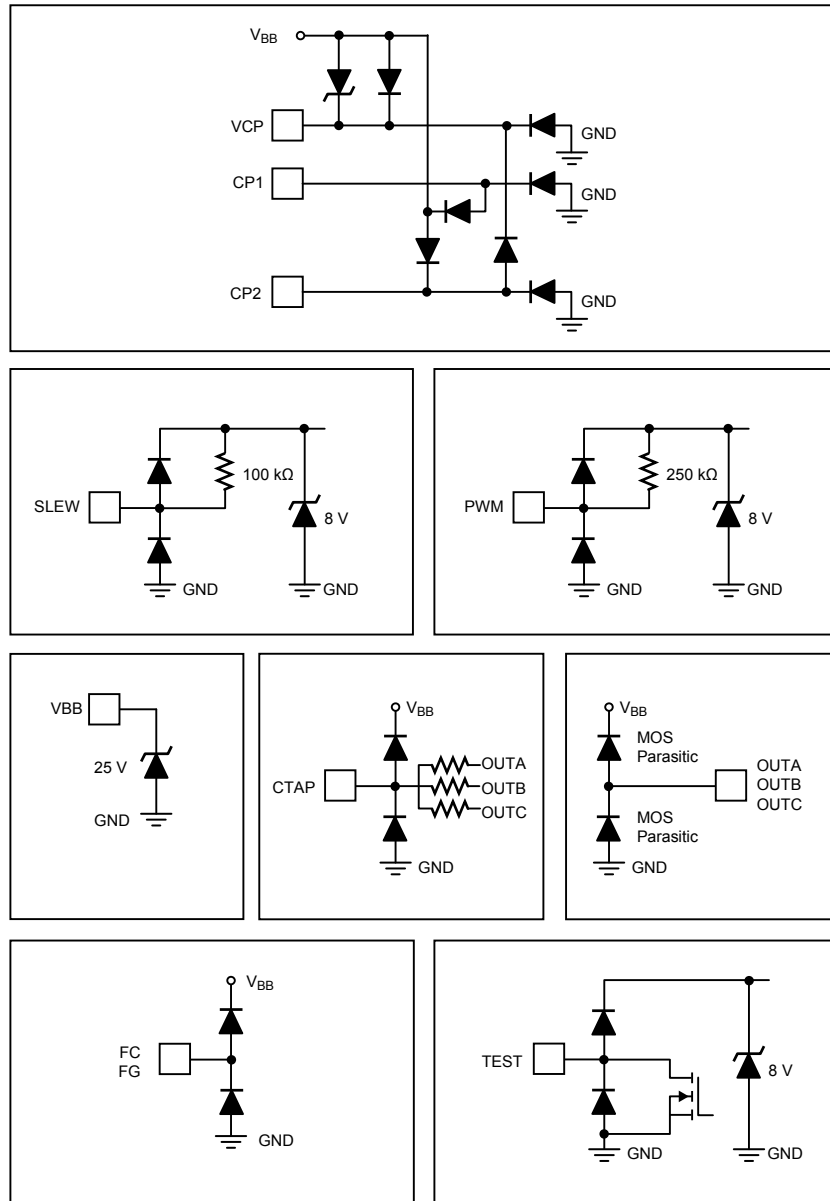

APPLICATION INFORMATION

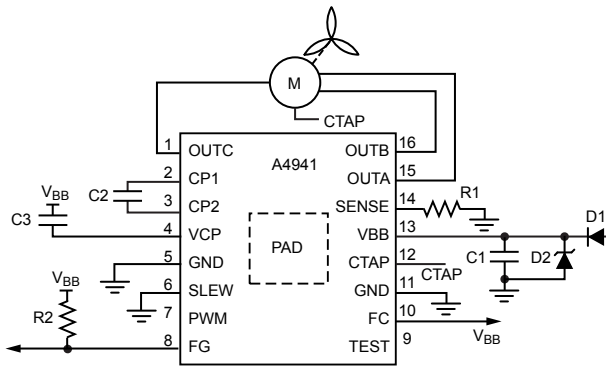

Typical Application Circuit; speed adjusted via VBB

Name	Typical Value	Description
C1	10 μ F / 25 V	VBB supply capacitor, minimum 10 μ F, electrolytic can be used
C2,C3	0.1 μ F / 25 V	Charge pump ceramic capacitors
R2	10 k Ω	FG pull-up resistor, can be pulled-up to V _{BB} if required
D1	>1.5 A rated	Optional blocking diode for supply reverse polarity protection
D2	15 V	Transient voltage suppressor (TVS)
R1	0.167 Ω	Current limiting sense resistor, required for low resistance motors

STARTUP OSCILLATOR SETTING (FC)

Typically, the 50 ms setting is optimum for motors appropriate for use with the A4941. If the motor does not produce a proper BEMF signal at startup when power is applied, a longer setting may be required.

SLEW SETTING

Connect SLEW to ground to enable the soft switching function. For some motors, soft switching may reduce audible noise. Enabling the soft switching function can result in motor stall for some motors, specifically motors with large inductance that run at higher speeds. For this situation, there are two potential solutions:

- Limit the motor speed by lowering the maximum demand, by reducing either $V_{motor(max)}$ or the PWM duty applied.
- Disable soft switching by leaving SLEW pin open circuit.

CURRENT LIMITING

Use of the current limit circuit is not required. If motor resistance (phase-to-phase) will limit the current below the rating in the

Absolute Maximum table, then simply connect the SENSE pin to ground. That is:

- If $(V_{BB(max)} / R_{motor}) < 1.25$ A, eliminate R_S .
- If $(V_{BB(max)} / R_{motor}) > I_{OUT(max)}$, the choice of R_S determines the current limit setting; recommended range is 167 m Ω $< R_S < 250$ m Ω .

Note: For some motor types, use of the current limit circuit may prevent proper startup due to the effect of the chopping on the BEMF voltage appearing on the tri-stated winding.

LAYOUT NOTES

- Connect GND pins (5,11) to exposed pad ground area under package.
- Add thermal vias from exposed pad to bottom side ground plane.
- Place V_{BB} decoupling capacitor as close to the IC as possible.
- Place sense resistor, (if used), as close to the IC as possible.

REVISION HISTORY

Number	Date	Description
4	December 20, 2012	Add information on CTAP, Automotive variant
5	February 24, 2015	Added to CTAP information
6	September 21, 2018	Updated product status to not for new design; minor editorial updates
7	October 7, 2019	Minor editorial updates

Copyright 2019, Allegro MicroSystems.

Allegro MicroSystems reserves the right to make, from time to time, such departures from the detail specifications as may be required to permit improvements in the performance, reliability, or manufacturability of its products. Before placing an order, the user is cautioned to verify that the information being relied upon is current.

Allegro's products are not to be used in any devices or systems, including but not limited to life support devices or systems, in which a failure of Allegro's product can reasonably be expected to cause bodily harm.

The information included herein is believed to be accurate and reliable. However, Allegro MicroSystems assumes no responsibility for its use; nor for any infringement of patents or other rights of third parties which may result from its use.

Copies of this document are considered uncontrolled documents.

For the latest version of this document, visit our website:

www.allegromicro.com