

| REVISIONS | | | | | |
|-----------|-----|---------------------------|-----------|-----|------|
| P | LTR | DESCRIPTION | DATE | DWN | APVD |
| | A2 | REVISED PER ECN-21-122181 | 26OCT2021 | RZ | WK |

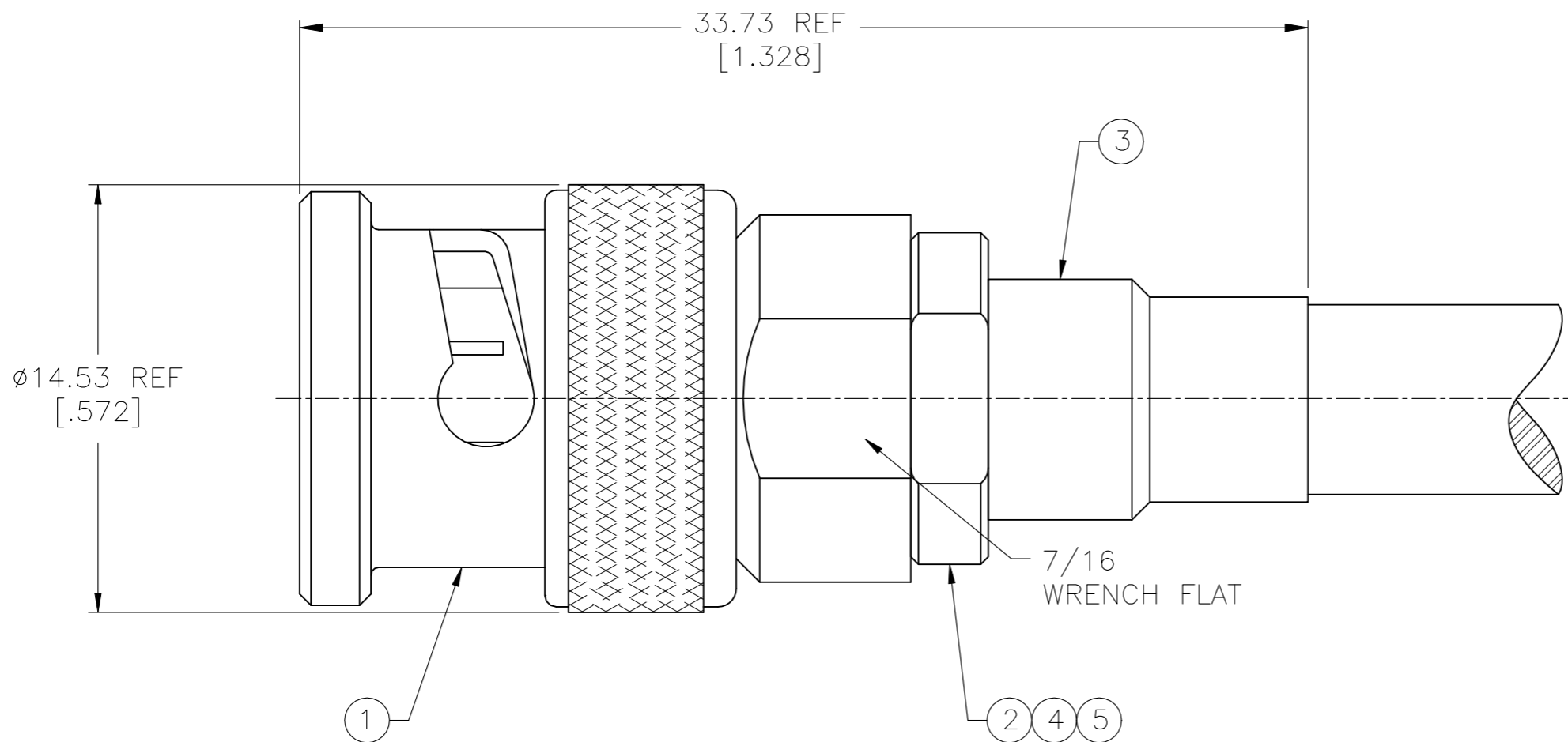

- USE PRO-CRIMPER 354940-1 WITH DIE SET 91909-1.
 - SEE INSTRUCTION SHEET 408-2055.
 - PARTS PACKAGED UNASSEMBLED.
- △ 4 OBSOLETE PARTS: OBSOLETE CIS STREAMLINING PER D.RENAUD/D.SINISI

| | | | | | | | | |
|-----|----------|---------------------|--------------|--------------------|-----------------|-------------------|-------------------|----------------------|
| △ 4 | OBSOLETE | ROLM 49D2401 TWINAX | 332214 | 332222-1 | 9-332224-0 | 1-332221-5 | 5-330949-0 | 5332225-6 |
| | | RG 108/U & 108A/U | 332214 | 332222-1 | 9-332224-0 | 1-332221-4 | 5-330949-0 | 5332225-5 |
| △ 4 | OBSOLETE | TROMPETER TWC-124-2 | 332214 | 332222 | 9-332224-1 | 1-332221-3 | 2-330949-2 | 5332225-3 |
| | | RG 108/U & 108A/U | 332214 | 332222 | 9-332224-1 | 332221 | 2-330949-2 | 5332225 |
| | | FOR USE WITH CABLE | ⑤ SEAL QTY=1 | ④ DIELECTRIC QTY=1 | ③ FERRULE QTY=1 | ② CRIMP END QTY=1 | ① PLUG ASSY QTY=1 | PART NO. |

THIS DRAWING IS A CONTROLLED DOCUMENT.

| | | | | |
|----------------------------|--|---------------------------------------|----------------------------|---------------|
| DIMENSIONS: mm [INCHES] | TOLERANCES UNLESS OTHERWISE SPECIFIED: | DWN L. VARELA - DOCK5 21APR2005 | STE TE Connectivity | |
| | 0 PLC ± - 1 PLC ± - 2 PLC ± - 3 PLC ± - 4 PLC ± - ANGLES ± 1° | CHK J. HAVENER 21APR2005 | | |
| MATERIAL | FINISH | PRODUCT SPEC | NAME PLUG, TWIN BNC | |
| - | - | APPLICATION SPEC | SIZE | CAGE CODE |
| | | WEIGHT 0.000000 | A3 | 00779 |
| | | CUSTOMER DRAWING | DRAWING NO | RESTRICTED TO |
| | | | C-5332225 | - |
| | | SCALE 5:1 | SHEET 1 OF 1 | REV A2 |