

## AD7854/AD7854L

### FEATURES

Specified for  $V_{DD}$  of 3 V to 5.5 V  
Read-Only Operation  
AD7854–200 kSPS; AD7854L–100 kSPS  
System and Self-Calibration  
Low Power

#### Normal Operation

AD7854: 15 mW ( $V_{DD} = 3$  V)

AD7854L: 5.5 mW ( $V_{DD} = 3$  V)

#### Automatic Power-Down After Conversion (25 $\mu$ W)

AD7854: 1.3 mW 10 kSPS

AD7854L: 650  $\mu$ W 10 kSPS

#### Flexible Parallel Interface

12-Bit Parallel/8-Bit Parallel (AD7854)

28-Lead DIP, SOIC and SSOP Packages (AD7854)

### APPLICATIONS

Battery-Powered Systems (Personal Digital Assistants,  
Medical Instruments, Mobile Communications)

Pen Computers

Instrumentation and Control Systems

High Speed Modems

### FUNCTIONAL BLOCK DIAGRAM

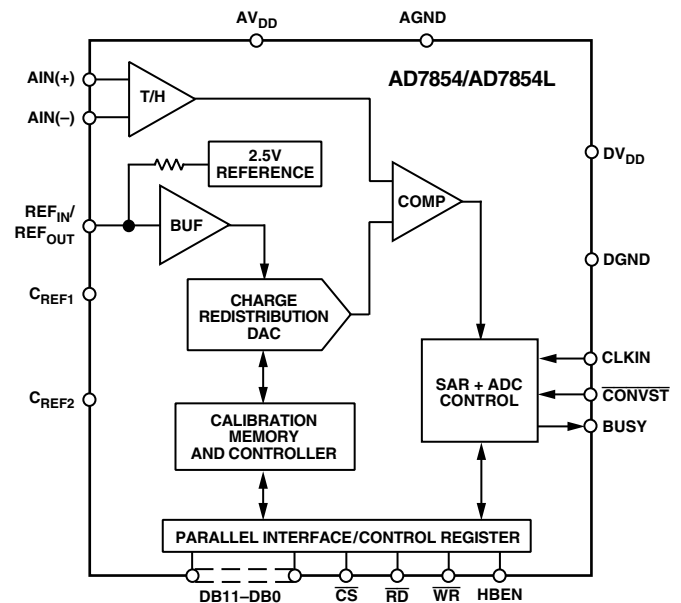

### GENERAL DESCRIPTION

The AD7854/AD7854L is a high speed, low power, 12-bit ADC that operates from a single 3 V or 5 V power supply, the AD7854 being optimized for speed and the AD7854L for low power. The ADC powers up with a set of default conditions at which time it can be operated as a read-only ADC. The ADC contains self-calibration and system calibration options to ensure accurate operation over time and temperature and has a number of power-down options for low power applications.

The AD7854 is capable of 200 kHz throughput rate while the AD7854L is capable of 100 kHz throughput rate. The input track-and-hold acquires a signal in 500 ns and features a pseudo-differential sampling scheme. The AD7854 and AD7854L input voltage range is 0 to  $V_{REF}$  (unipolar) and  $-V_{REF}/2$  to  $+V_{REF}/2$ , centered at  $V_{REF}/2$  (bipolar). The coding is straight binary in unipolar mode and twos complement in bipolar mode. Input signal range is to the supply and the part is capable of converting full-power signals to 100 kHz.

CMOS construction ensures low power dissipation of typically 5.4 mW for normal operation and 3.6  $\mu$ W in power-down mode. The part is available in 28-lead, 0.6 inch wide dual-in-line package (DIP), 28-lead small outline (SOIC) and 28-lead small shrink outline (SSOP) packages.

See Page 27 for data sheet index.

### REV. B

Information furnished by Analog Devices is believed to be accurate and reliable. However, no responsibility is assumed by Analog Devices for its use, nor for any infringements of patents or other rights of third parties which may result from its use. No license is granted by implication or otherwise under any patent or patent rights of Analog Devices.

### PRODUCT HIGHLIGHTS

1. Operation with either 3 V or 5 V power supplies.
2. Flexible power management options including automatic power-down after conversion. By using the power management options a superior power performance at slower throughput rates can be achieved:  
AD7854: 1 mW typ @ 10 kSPS  
AD7854L: 1 mW typ @ 20 kSPS
3. Operates with reference voltages from 1.2 V to  $AV_{DD}$ .
4. Analog input ranges from 0 V to  $AV_{DD}$ .
5. Self-calibration and system calibration.
6. Versatile parallel I/O port.
7. Lower power version AD7854L.

# AD7854/AD7854L—SPECIFICATIONS<sup>1, 2</sup>

( $A_{V_{DD}} = DV_{DD} = +3.0\text{ V to }+5.5\text{ V}$ ,  $REF_{IN}/REF_{OUT} = 2.5\text{ V}$ )

External Reference,  $f_{CLKIN} = 4\text{ MHz}$  (for L Version:  $1.8\text{ MHz}$  ( $0^{\circ}\text{C to }+70^{\circ}\text{C}$ ) and  $1\text{ MHz}$  ( $-40^{\circ}\text{C to }+85^{\circ}\text{C}$ ));  $f_{SAMPLE} = 200\text{ kHz}$  (AD7854),  $100\text{ kHz}$  (AD7854L);  $T_A = T_{MIN}$  to  $T_{MAX}$ , unless otherwise noted.) Specifications in ( ) apply to the AD7854L.

Parameter	A Version <sup>1</sup>	B Version <sup>1</sup>	S Version <sup>1</sup>	Units	Test Conditions/Comments	
<b>DYNAMIC PERFORMANCE</b>						
Signal to Noise + Distortion Ratio <sup>3</sup> (SNR)	70	71	70	dB min	Typically SNR is 72 dB $V_{IN} = 10\text{ kHz Sine Wave}$ , $f_{SAMPLE} = 200\text{ kHz}$ (L Version: $f_{SAMPLE} = 100\text{ kHz @ }f_{CLKIN} = 2\text{ MHz}$ )	
Total Harmonic Distortion (THD)	-78	-78	-78	dB max	$V_{IN} = 10\text{ kHz Sine Wave}$ , $f_{SAMPLE} = 200\text{ kHz}$ (L Version: $f_{SAMPLE} = 100\text{ kHz @ }f_{CLKIN} = 2\text{ MHz}$ )	
Peak Harmonic or Spurious Noise	-78	-78	-78	dB max	$V_{IN} = 10\text{ kHz Sine Wave}$ , $f_{SAMPLE} = 200\text{ kHz}$ (L Version: $f_{SAMPLE} = 100\text{ kHz @ }f_{CLKIN} = 2\text{ MHz}$ )	
Intermodulation Distortion (IMD) Second Order Terms	-78	-78	-78	dB typ	$f_a = 9.983\text{ kHz}$ , $f_b = 10.05\text{ kHz}$ , $f_{SAMPLE} = 200\text{ kHz}$ (L Version: $f_{SAMPLE} = 100\text{ kHz @ }f_{CLKIN} = 2\text{ MHz}$ )	
Third Order Terms	-78	-78	-78	dB typ	$f_a = 9.983\text{ kHz}$ , $f_b = 10.05\text{ kHz}$ , $f_{SAMPLE} = 200\text{ kHz}$ (L Version: $f_{SAMPLE} = 100\text{ kHz @ }f_{CLKIN} = 2\text{ MHz}$ )	
<b>DC ACCURACY</b>						
Resolution	12	12	12	Bits	5 V Reference $V_{DD} = 5\text{ V}$ Guaranteed No Missed Codes to 12 Bits	
Integral Nonlinearity	$\pm 1$	$\pm 0.5$	$\pm 1$	LSB max		
Differential Nonlinearity	$\pm 1$	$\pm 1$	$\pm 1$	LSB max		
Unipolar Offset Error	$\pm 3$	$\pm 3$	$\pm 4$	LSB max		
	$\pm 2$	$\pm 2$	$\pm 2$	LSB typ		
Unipolar Gain Error	$\pm 4$	$\pm 4$	$\pm 4$	LSB max		
	$\pm 2$	$\pm 2$	$\pm 2$	LSB typ		
Bipolar Positive Full-Scale Error	$\pm 4$	$\pm 4$	$\pm 5$	LSB max		
	$\pm 2$	$\pm 2$	$\pm 2$	LSB typ		
Negative Full-Scale Error	$\pm 4$	$\pm 4$	$\pm 5$	LSB max		
	$\pm 2$	$\pm 2$	$\pm 2$	LSB typ		
Bipolar Zero Error	$\pm 4$	$\pm 4$	$\pm 5$	LSB max		
<b>ANALOG INPUT</b>						
Input Voltage Ranges	0 to $V_{REF}$	0 to $V_{REF}$	0 to $V_{REF}$	Volts	i.e., $A_{IN}(+) - A_{IN}(-) = 0$ to $V_{REF}$ ; $A_{IN}(-)$ can be biased up but $A_{IN}(+)$ cannot go below $A_{IN}(-)$ . i.e., $A_{IN}(+) - A_{IN}(-) = -V_{REF}/2$ to $+V_{REF}/2$ , $A_{IN}(-)$ should be biased to $+V_{REF}/2$ and $A_{IN}(+)$ can go below $A_{IN}(-)$ but cannot go below 0 V.	
	$\pm V_{REF}/2$	$\pm V_{REF}/2$	$\pm V_{REF}/2$	Volts		
Leakage Current	$\pm 1$	$\pm 1$	$\pm 1$	$\mu\text{A max}$		
Input Capacitance	20	20	20	pF typ		
<b>REFERENCE INPUT/OUTPUT</b>						
$REF_{IN}$ Input Voltage Range	$2.3/V_{DD}$	$2.3/V_{DD}$	$2.3/V_{DD}$	V min/max	Functional from 1.2 V	
Input Impedance	150	150	150	k $\Omega$ typ		
$REF_{OUT}$ Output Voltage	2.3/2.75	2.3/2.7	2.3/2.7	V min/max		
$REF_{OUT}$ Tempco	20	20	20	ppm/ $^{\circ}\text{C}$ typ		
<b>LOGIC INPUTS</b>						
Input High Voltage, $V_{INH}$	3	3	3	V min	$A_{V_{DD}} = DV_{DD} = 4.5\text{ V to }5.5\text{ V}$ $A_{V_{DD}} = DV_{DD} = 3.0\text{ V to }3.6\text{ V}$ $A_{V_{DD}} = DV_{DD} = 4.5\text{ V to }5.5\text{ V}$ $A_{V_{DD}} = DV_{DD} = 3.0\text{ V to }3.6\text{ V}$ Typically 10 nA, $V_{IN} = 0\text{ V}$ or $V_{DD}$	
	2.1	2.1	2.1	V min		
Input Low Voltage, $V_{INL}$	0.4	0.4	0.4	V max		
	0.6	0.6	0.6	V max		
Input Current, $I_{IN}$	$\pm 10$	$\pm 10$	$\pm 10$	$\mu\text{A max}$		
Input Capacitance, $C_{IN}^4$	10	10	10	pF max		
<b>LOGIC OUTPUTS</b>						
Output High Voltage, $V_{OH}$	4	4	4	V min		$I_{SOURCE} = 200\text{ }\mu\text{A}$ $A_{V_{DD}} = DV_{DD} = 4.5\text{ V to }5.5\text{ V}$ $A_{V_{DD}} = DV_{DD} = 3.0\text{ V to }3.6\text{ V}$
	2.4	2.4	2.4	V min		
Output Low Voltage, $V_{OL}$	0.4	0.4	0.4	V max	$I_{SINK} = 0.8\text{ mA}$	
Floating-State Leakage Current	$\pm 10$	$\pm 10$	$\pm 10$	$\mu\text{A max}$		
Floating-State Output Capacitance <sup>4</sup>	10	10	10	pF max		
Output Coding	Straight (Natural) Binary Twos Complement					Unipolar Input Range Bipolar Input Range
<b>CONVERSION RATE</b>						
Conversion Time	4.6 (10)	4.6 (9)	4.6 (9)	$\mu\text{s max}$	$t_{CLKIN} \times 18$ (L Versions Only, $0^{\circ}\text{C to }+70^{\circ}\text{C}$ , 1.8 MHz CLKIN)	
Track/Hold Acquisition Time	0.5 (1)	0.5 (1)	0.5 (1)	$\mu\text{s min}$	(L Versions Only, $-40^{\circ}\text{C to }+85^{\circ}\text{C}$ , 1 MHz CLKIN)	

Parameter	A Version <sup>1</sup>	B Version <sup>1</sup>	S Version <sup>1</sup>	Units	Test Conditions/Comments
<b>POWER REQUIREMENTS</b>					
$AV_{DD}, DV_{DD}$	+3.0/+5.5	+3.0/+5.5	+3.0/+5.5	V min/max	
$I_{DD}$					
Normal Mode <sup>5</sup>	5.5 (1.8)	5.5 (1.8)	6 (1.8)	mA max	$AV_{DD} = DV_{DD} = 4.5$ V to 5.5 V. Typically 4.5 mA (1.5 mA);
	5.5 (1.8)	5.5 (1.8)	6 (1.8)	mA max	$AV_{DD} = DV_{DD} = 3.0$ V to 3.6 V. Typically 4.0 mA (1.5 mA).
Sleep Mode <sup>6</sup>					
With External Clock On	10	10	10	$\mu$ A typ	Full power-down. Power management bits in control register set as PMGT1 = 1, PMGT0 = 0.
	400	400	400	$\mu$ A typ	Partial power-down. Power management bits in control register set as PMGT1 = 1, PMGT0 = 1.
With External Clock Off	5	5	5	$\mu$ A max	Typically 1 $\mu$ A. Full power-down. Power management bits in control register set as PMGT1 = 1, PMGT0 = 0.
	200	200	200	$\mu$ A typ	Partial power-down. Power management bits in control register set as PMGT1 = 1, PMGT0 = 1.
Normal Mode Power Dissipation	30 (10)	30 (10)	30 (10)	mW max	$V_{DD} = 5.5$ V: Typically 25 mW (8)
	20 (6.5)	20 (6.5)	20 (6.5)	mW max	$V_{DD} = 3.6$ V: Typically 15 mW (5.4)
Sleep Mode Power Dissipation					
With External Clock On	55	55	55	$\mu$ W typ	$V_{DD} = 5.5$ V
	36	36	36	$\mu$ W typ	$V_{DD} = 3.6$ V
With External Clock Off	27.5	27.5	27.5	$\mu$ W max	$V_{DD} = 5.5$ V: Typically 5.5 $\mu$ W
	18	18	18	$\mu$ W max	$V_{DD} = 3.6$ V: Typically 3.6 $\mu$ W
<b>SYSTEM CALIBRATION</b>					
Offset Calibration Span <sup>7</sup>	$+0.05 \times V_{REF} / -0.05 \times V_{REF}$			V max/min	Allowable Offset Voltage Span for Calibration
Gain Calibration Span <sup>7</sup>	$+0.025 \times V_{REF} / -0.025 \times V_{REF}$			V max/min	Allowable Full-Scale Voltage Span for Calibration

## NOTES

<sup>1</sup>Temperature ranges as follows: A, B Versions,  $-40^{\circ}\text{C}$  to  $+85^{\circ}\text{C}$ ; S Version,  $-55^{\circ}\text{C}$  to  $+125^{\circ}\text{C}$ .

<sup>2</sup>Specifications apply after calibration.

<sup>3</sup>Not production tested. Guaranteed by characterization at initial product release.

<sup>4</sup>Sample tested @  $+25^{\circ}\text{C}$  to ensure compliance.

<sup>5</sup>All digital inputs @ DGND except for  $\overline{\text{CONVST}}$  @  $DV_{DD}$ . No load on the digital outputs. Analog inputs @ AGND.

<sup>6</sup>CLKIN @ DGND when external clock off. All digital inputs @ DGND except for  $\overline{\text{CONVST}}$  @  $DV_{DD}$ . No load on the digital outputs. Analog inputs @ AGND.

<sup>7</sup>The offset and gain calibration spans are defined as the range of offset and gain errors that the AD7854/AD7854L can calibrate. Note also that these are voltage spans and are not absolute voltages (i.e., the allowable system offset voltage presented at AIN(+) for the system offset error to be adjusted out will be  $\text{AIN}(-) \pm 0.05 \times V_{REF}$ , and the allowable system full-scale voltage applied between AIN(+) and AIN(-) for the system full-scale voltage error to be adjusted out will be  $V_{REF} \pm 0.025 \times V_{REF}$  (unipolar mode) and  $V_{REF}/2 \pm 0.025 \times V_{REF}$  (bipolar mode)). This is explained in more detail in the calibration section of the data sheet.

Specifications subject to change without notice.

# AD7854/AD7854L

## TIMING SPECIFICATIONS<sup>1</sup> ( $AV_{DD} = DV_{DD} = +3.0\text{ V to }+5.5\text{ V}$ ; $f_{CLKIN} = 4\text{ MHz for AD7854 and }1.8\text{ MHz for AD7854L}$ ; $T_A = T_{MIN}\text{ to }T_{MAX}$ , unless otherwise noted)

Parameter	Limit at $T_{MIN}$ , $T_{MAX}$ (A, B, S Versions)		Units	Description
	5 V	3 V		
$f_{CLKIN}$ <sup>2</sup>	500 4 1.8	500 4 1.8	kHz min MHz max MHz max	Master Clock Frequency
$t_1$ <sup>3</sup>	100	100	ns min	L Version $\overline{CONVST}$ Pulsewidth
$t_2$	50	90	ns max	$\overline{CONVST}$ to $BUSY \uparrow$ Propagation Delay
$t_{CONVERT}$	4.5 10	4.5 10	$\mu\text{s max}$ $\mu\text{s max}$	Conversion Time = $18 t_{CLKIN}$ L Version 1.8 MHz CLKIN. Conversion Time = $18 t_{CLKIN}$
$t_3$	15	15	ns min	$HBEN$ to $\overline{RD}$ Setup Time
$t_4$	5	5	ns min	$HBEN$ to $\overline{RD}$ Hold Time
$t_5$	0	0	ns min	$\overline{CS}$ to $\overline{RD}$ Setup Time
$t_6$	0	0	ns min	$\overline{CS}$ to $\overline{RD}$ Hold Time
$t_7$	55	70	ns min	$\overline{RD}$ Pulsewidth
$t_8$ <sup>4</sup>	50	50	ns max	Data Access Time After $\overline{RD}$
$t_9$ <sup>5</sup>	5 40	5 40	ns min ns max	Bus Relinquish Time After $\overline{RD}$
$t_{10}$	60	70	ns min	Minimum Time Between Reads
$t_{11}$	0	0	ns min	$HBEN$ to $\overline{WR}$ Setup Time
$t_{12}$	5	5	ns max	$HBEN$ to $\overline{WR}$ Hold Time
$t_{13}$	0	0	ns min	$\overline{CS}$ to $\overline{WR}$ Setup Time
$t_{14}$	0	0	ns max	$\overline{CS}$ to $\overline{WR}$ Hold Time
$t_{15}$	55	70	ns min	$\overline{WR}$ Pulsewidth
$t_{16}$	10	10	ns min	Data Setup Time Before $\overline{WR}$
$t_{17}$	5	5	ns min	Data Hold Time After $\overline{WR}$
$t_{18}$ <sup>4</sup>	$1/2 t_{CLKIN}$	$1/2 t_{CLKIN}$	ns min	New Data Valid Before Falling Edge of $BUSY$
$t_{19}$	50	70	ns min	$HBEN$ High Pulse Duration
$t_{20}$	50	70	ns min	$HBEN$ Low Pulse Duration
$t_{21}$	40	60	ns min	Propagation Delay from $HBEN$ Rising Edge to Data Valid
$t_{22}$	40	60	ns min	Propagation Delay from $HBEN$ Falling Edge to Data Valid
$t_{23}$	$2.5 t_{CLKIN}$	$2.5 t_{CLKIN}$	ns max	$\overline{CS} \uparrow$ to $BUSY \uparrow$ in Calibration Sequence
$t_{CAL}$ <sup>6</sup>	31.25	31.25	ms typ	Full Self-Calibration Time, Master Clock Dependent ( $125013 t_{CLKIN}$ )
$t_{CAL1}$ <sup>6</sup>	27.78	27.78	ms typ	Internal DAC Plus System Full-Scale Cal Time, Master Clock Dependent ( $111124 t_{CLKIN}$ )
$t_{CAL2}$ <sup>6</sup>	3.47	3.47	ms typ	System Offset Calibration Time, Master Clock Dependent ( $13889 t_{CLKIN}$ )

### NOTES

<sup>1</sup>Sample tested at +25°C to ensure compliance. All input signals are specified with  $t_r = t_f = 5\text{ ns}$  (10% to 90% of  $V_{DD}$ ) and timed from a voltage level of 1.6 V.

<sup>2</sup>Mark/Space ratio for the master clock input is 40/60 to 60/40.

<sup>3</sup>The  $\overline{CONVST}$  pulsewidth here only applies for normal operation. When the part is in power-down mode, a different  $\overline{CONVST}$  pulsewidth applies (see Power-Down section).

<sup>4</sup>Measured with the load circuit of Figure 1 and defined as the time required for the output to cross 0.8 V or 2.4 V.

<sup>5</sup> $t_9$  is derived from the measured time taken by the data outputs to change 0.5 V when loaded with the circuit of Figure 1. The measured number is then extrapolated back to remove the effects of charging or discharging the 50 pF capacitor. This means that the time,  $t_9$ , quoted in the timing characteristics is the true bus relinquish time of the part and is independent of the bus loading.

<sup>6</sup>The typical time specified for the calibration times is for a master clock of 4 MHz. For the L version the calibration times will be longer than those quoted here due to the 1.8 MHz master clock.

Specifications subject to change without notice.

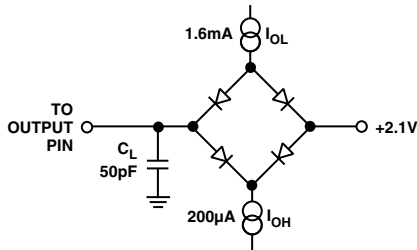
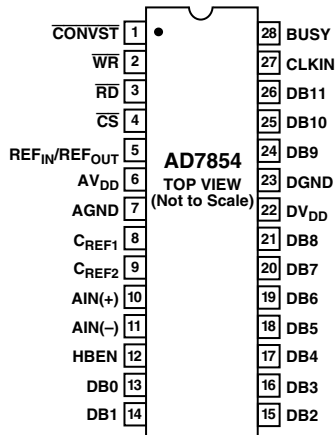

Figure 1. Load Circuit for Digital Output Timing Specifications

### PIN CONFIGURATION FOR DIP, SOIC AND SSOP



### ABSOLUTE MAXIMUM RATINGS<sup>1</sup>

(T<sub>A</sub> = +25°C unless otherwise noted)

AV <sub>DD</sub> to AGND	.....	-0.3 V to +7 V
DV <sub>DD</sub> to DGND	.....	-0.3 V to +7 V
AV <sub>DD</sub> to DV <sub>DD</sub>	.....	-0.3 V to +0.3 V
Analog Input Voltage to AGND	....	-0.3 V to AV <sub>DD</sub> + 0.3 V
Digital Input Voltage to DGND	....	-0.3 V to DV <sub>DD</sub> + 0.3 V
Digital Output Voltage to DGND	....	-0.3 V to DV <sub>DD</sub> + 0.3 V
REF <sub>IN</sub> /REF <sub>OUT</sub> to AGND	.....	-0.3 V to AV <sub>DD</sub> + 0.3 V
Input Current to Any Pin Except Supplies <sup>2</sup>	.....	±10 mA
Operating Temperature Range		
Commercial (A, B Versions)	.....	-40°C to +85°C
Commercial (S Version)	.....	-55°C to +125°C
Storage Temperature Range	.....	-65°C to +150°C
Junction Temperature	.....	+150°C
Cerdip Package, Power Dissipation	.....	450 mW
θ <sub>JA</sub> Thermal Impedance	.....	75°C/W
Lead Temperature, (Soldering, 10 secs)	.....	+300°C
SOIC, SSOP Package, Power Dissipation	.....	450 mW
θ <sub>JA</sub> Thermal Impedance	... ..	75°C/W (SOIC) 115°C/W (SSOP)
θ <sub>JC</sub> Thermal Impedance	... ..	25°C/W (SOIC) 35°C/W (SSOP)
Lead Temperature, Soldering		
Vapor Phase (60 secs)	.....	+215°C
Infrared (15 secs)	.....	+220°C

### NOTES

<sup>1</sup>Stresses above those listed under Absolute Maximum Ratings may cause permanent damage to the device. This is a stress rating only; functional operation of the device at these or any other conditions above those listed in the operational sections of this specification is not implied. Exposure to absolute maximum rating conditions for extended periods may affect device reliability.

<sup>2</sup>Transient currents of up to 100 mA will not cause SCR latchup.

### ORDERING GUIDE

Model	Temperature Range <sup>1</sup>	Linearity Error (LSB)	Power Dissipation (mW)	Package Option <sup>2</sup>
AD7854AQ	-40°C to +85°C	1	15	Q-28
AD7854SQ	-55°C to +125°C	1	15	Q-28
AD7854AR	-40°C to +85°C	1	15	R-28
AD7854BR	-40°C to +85°C	1/2	15	R-28
AD7854ARS	-40°C to +85°C	1	15	RS-28
AD7854LAQ <sup>3</sup>	-40°C to +85°C	1	5.5	Q-28
AD7854LAR <sup>3</sup>	-40°C to +85°C	1	5.5	R-28
AD7854LARS <sup>3</sup>	-40°C to +85°C	1	5.5	RS-28
EVAL-AD7854CB <sup>4</sup>				
EVAL-CONTROL BOARD <sup>5</sup>				

### NOTES

<sup>1</sup>Linearity error refers to the integral linearity error.

<sup>2</sup>Q = Cerdip; R = SOIC; RS = SSOP.

<sup>3</sup>L signifies the low power version.

<sup>4</sup>This can be used as a stand-alone evaluation board or in conjunction with the EVAL-CONTROL BOARD for evaluation/demonstration purposes.

<sup>5</sup>This board is a complete unit allowing a PC to control and communicate with all Analog Devices evaluation boards ending in the CB designator. For more information on Analog Devices products and evaluation boards visit our World Wide Web home page at <http://www.analog.com>.

# AD7854/AD7854L

## PIN FUNCTION DESCRIPTIONS

Pin	Mnemonic	Description
1	$\overline{\text{CONVST}}$	Convert Start. Logic input. A low to high transition on this input puts the track/hold into its hold mode and starts conversion. When this input is not used, it should be tied to $\text{DV}_{\text{DD}}$ .
2	$\overline{\text{WR}}$	Write Input. Active low logic input. Used in conjunction with $\overline{\text{CS}}$ and HBEN to write to internal registers.
3	$\overline{\text{RD}}$	Read Input. Active low logic input. Used in conjunction with $\overline{\text{CS}}$ and HBEN to read from internal registers.
4	$\overline{\text{CS}}$	Chip Select Input. Active low logic input. The device is selected when this input is active.
5	$\text{REF}_{\text{IN}}/\text{REF}_{\text{OUT}}$	Reference Input/Output. This pin is connected to the internal reference through a series resistor and is the reference source for the analog-to-digital converter. The nominal reference voltage is 2.5 V and this appears at the pin. This pin can be overdriven by an external reference and can be taken as high as $\text{AV}_{\text{DD}}$ . When this pin is tied to $\text{AV}_{\text{DD}}$ , then the $\text{C}_{\text{REF1}}$ pin should also be tied to $\text{AV}_{\text{DD}}$ .
6	$\text{AV}_{\text{DD}}$	Analog Positive Supply Voltage, +3.0 V to +5.5 V.
7	AGND	Analog Ground. Ground reference for track/hold, reference and DAC.
8	$\text{C}_{\text{REF1}}$	Reference Capacitor (0.1 $\mu\text{F}$ multilayer ceramic). This external capacitor is used as a charge source for the internal DAC. The capacitor should be tied between the pin and AGND.
9	$\text{C}_{\text{REF2}}$	Reference Capacitor (0.01 $\mu\text{F}$ ceramic disc). This external capacitor is used in conjunction with the on-chip reference. The capacitor should be tied between the pin and AGND.
10	$\text{AIN}(+)$	Analog Input. Positive input of the pseudo-differential analog input. Cannot go below AGND or above $\text{AV}_{\text{DD}}$ at any time, and cannot go below $\text{AIN}(-)$ when the unipolar input range is selected.
11	$\text{AIN}(-)$	Analog Input. Negative input of the pseudo-differential analog input. Cannot go below AGND or above $\text{AV}_{\text{DD}}$ at any time.
12	HBEN	High Byte Enable Input. The AD7854 operates in byte mode only but outputs 12 bits of data during a read cycle with HBEN low. When HBEN is high, then the high byte of data that is written to or read from the part is on DB0 to DB7. When HBEN is low, then the lowest byte of data being written to the part is on DB0 to DB7. If reading from the part with HBEN low, then the lowest 12 bits of data appear on pins DB0 to DB11. This allows a single read from the ADC or from the control register in a 16-bit bus system. However, two reads are needed to access the calibration registers. Also, two writes are necessary to write to any of the registers.
13–21	DB0–DB8	Data Bits 0 to 8. Three state data I/O pins that are controlled by $\overline{\text{CS}}$ , $\overline{\text{RD}}$ , $\overline{\text{WR}}$ and HBEN. Data output is straight binary (unipolar mode) or twos complement (bipolar mode).
22	$\text{DV}_{\text{DD}}$	Digital Supply Voltage, +3.0 V to +5.5 V.
23	DGND	Digital Ground. Ground reference point for digital circuitry.
24–26	DB9–DB11	Data Bits 9 to 11. Three state data output pins that are controlled by $\overline{\text{CS}}$ , $\overline{\text{RD}}$ and HBEN. Data output is straight binary (unipolar mode) or twos complement (bipolar mode). These output pins should be tied to $\text{DV}_{\text{DD}}$ via 100 k $\Omega$ resistors when the AD7854/AD7854L is being interfaced to an 8-bit data bus.
27	CLKIN	Master Clock Signal for the device (4 MHz for AD7854, 1.8 MHz for AD7854L). Sets the conversion and calibration times.
28	BUSY	Busy Output. The busy output is triggered high by the falling edge of $\overline{\text{CONVST}}$ and remains high until conversion is completed. BUSY is also used to indicate when the AD7854/AD7854L has completed its on-chip calibration sequence.

**TERMINOLOGY****Integral Nonlinearity**

This is the maximum deviation from a straight line passing through the endpoints of the ADC transfer function. The endpoints of the transfer function are zero scale, a point 1/2 LSB below the first code transition, and full scale, a point 1/2 LSB above the last code transition.

**Differential Nonlinearity**

This is the difference between the measured and the ideal 1 LSB change between any two adjacent codes in the ADC.

**Unipolar Offset Error**

This is the deviation of the first code transition (00 . . . 000 to 00 . . . 001) from the ideal AIN(+) voltage (AIN(-) + 1/2 LSB) when operating in the unipolar mode.

**Unipolar Gain Error**

This is the deviation of the last code transition (111 . . . 110 to 111 . . . 111) from the ideal, i.e., AIN(-) + V<sub>REF</sub>/2 - 1.5 LSB, after the unipolar offset error has been adjusted out.

**Bipolar Positive Full-Scale Error**

This applies to the bipolar modes only and is the deviation of the last code transition from the ideal AIN(+) voltage. For bipolar mode, the ideal AIN(+) voltage is (AIN(-) + V<sub>REF</sub>/2 - 1.5 LSB).

**Negative Full-Scale Error**

This applies to the bipolar mode only and is the deviation of the first code transition (10 . . . 000 to 10 . . . 001) from the ideal AIN(+) voltage (AIN(-) - V<sub>REF</sub>/2 + 0.5 LSB).

**Bipolar Zero Error**

This is the deviation of the midscale transition (all 0s to all 1s) from the ideal AIN(+) voltage (AIN(-) - 1/2 LSB).

**Track/Hold Acquisition Time**

The track/hold amplifier returns into track mode and the end of conversion. Track/Hold acquisition time is the time required for the output of the track/hold amplifier to reach its final value, within ±1/2 LSB, after the end of conversion.

**Signal to (Noise + Distortion) Ratio**

This is the measured ratio of signal to (noise + distortion) at the output of the A/D converter. The signal is the rms amplitude of the fundamental. Noise is the sum of all nonfundamental signals up to half the sampling frequency (f<sub>s</sub>/2), excluding dc. The ratio is dependent on the number of quantization levels in the digitization process; the more levels, the smaller the quantization noise. The theoretical signal to (noise + distortion) ratio for an ideal N-bit converter with a sine wave input is given by:

$$\text{Signal to (Noise + Distortion)} = (6.02 N + 1.76) \text{ dB}$$

Thus for a 12-bit converter, this is 74 dB.

**Total Harmonic Distortion**

Total harmonic distortion (THD) is the ratio of the rms sum of harmonics to the fundamental. For the AD7854/AD7854L, it is defined as:

$$\text{THD (dB)} = 20 \log \frac{\sqrt{(V_2^2 + V_3^2 + V_4^2 + V_5^2 + V_6^2)}}{V_1}$$

where V<sub>1</sub> is the rms amplitude of the fundamental and V<sub>2</sub>, V<sub>3</sub>, V<sub>4</sub>, V<sub>5</sub> and V<sub>6</sub> are the rms amplitudes of the second through the sixth harmonics.

**Peak Harmonic or Spurious Noise**

Peak harmonic or spurious noise is defined as the ratio of the rms value of the next largest component in the ADC output spectrum (up to f<sub>s</sub>/2 and excluding dc) to the rms value of the fundamental. Normally, the value of this specification is determined by the largest harmonic in the spectrum, but for ADCs where the harmonics are buried in the noise floor, it will be a noise peak.

**Intermodulation Distortion**

With inputs consisting of sine waves at two frequencies, f<sub>a</sub> and f<sub>b</sub>, any active device with nonlinearities will create distortion products at sum and difference frequencies of m f<sub>a</sub> ± n f<sub>b</sub> where m, n = 0, 1, 2, 3, etc. Intermodulation distortion terms are those for which neither m nor n are equal to zero. For example, the second order terms include (f<sub>a</sub> + f<sub>b</sub>) and (f<sub>a</sub> - f<sub>b</sub>), while the third order terms include (2f<sub>a</sub> + f<sub>b</sub>), (2f<sub>a</sub> - f<sub>b</sub>), (f<sub>a</sub> + 2f<sub>b</sub>) and (f<sub>a</sub> - 2f<sub>b</sub>).

Testing is performed using the CCIF standard where two input frequencies near the top end of the input bandwidth are used. In this case, the second order terms are usually distanced in frequency from the original sine waves while the third order terms are usually at a frequency close to the input frequencies. As a result, the second and third order terms are specified separately. The calculation of the intermodulation distortion is as per the THD specification where it is the ratio of the rms sum of the individual distortion products to the rms amplitude of the sum of the fundamentals expressed in dBs.

# AD7854/AD7854L

## AD7854/AD7854L ON-CHIP REGISTERS

The AD7854/AD7854L powers up with a set of default conditions, and the user need not ever write to the device. In this case the AD7854/AD7854L will operate as a read-only ADC. The  $\overline{WR}$  pin should be tied to  $DV_{DD}$  for operating the AD7854/AD7854L as a read-only ADC.

Extra features and flexibility such as performing different power-down options, different types of calibrations including system calibration, and software conversion start can be selected by writing to the part.

The AD7854/AD7854L contains a **control register**, **ADC output data register**, **status register**, **test register** and **10 calibration registers**. The control register is write-only, the ADC output data register and the status register are read-only, and the test and calibration registers are both read/write registers. The test register is used for testing the part and should not be written to.

### Addressing the On-Chip Registers

#### Writing

To write to the AD7854/AD7854L, a 16-bit word of data must be transferred. This transfer consists of two 8-bit writes. The first 8 bits of data that are written *must* consist of the 8 LSBs of the 16-bit word and the second 8 bits that are written *must* consist of the 8 MSBs of the 16-bit word. For each of these 8-bit writes, the data is placed on Pins DB0 to DB7, Pin DB0 being the LSB of each transfer and Pin DB7 being the MSB of each transfer. The two MSBs of the 16-bit word, ADDR1 and ADDR0, are decoded to determine which register is addressed, and the 14 LSBs are written to the addressed register. Table I shows the decoding of the address bits, while Figure 2 shows the overall write register hierarchy.

Table I. Write Register Addressing

ADDR1	ADDR0	Comment
0	0	This combination does not address any register.
0	1	This combination addresses the <b>TEST REGISTER</b> . The 14 LSBs of data are written to the test register.
1	0	This combination addresses the <b>CALIBRATION REGISTER</b> . The 14 least significant data bits are written to the selected calibration register.
1	1	This combination addresses the <b>CONTROL REGISTER</b> . The 14 least significant data bits are written to the control register.

#### Reading

To read from the various registers the user must first write to Bits 6 and 7 in the Control Register, RDSLT0 and RDSLT1. These bits are decoded to determine which register is addressed during a read operation. Table II shows the decoding of the read address bits while Figure 3 shows the overall read register hierarchy. The power-up status of these bits is 00 so that the default read will be from the ADC output data register. Note: when reading from the calibration registers, the low byte must always be read first.

Once the read selection bits are set in the control register all subsequent read operations that follow are from the selected register until the read selection bits are changed in the control register.

Table II. Read Register Addressing

RDSLT1	RDSLT0	Comment
0	0	All successive read operations are from the <b>ADC OUTPUT DATA REGISTER</b> . This is the default power-up setting. There is always four leading zeros when reading from the ADC output data register.
0	1	All successive read operations are from the <b>TEST REGISTER</b> .
1	0	All successive read operations are from the <b>CALIBRATION REGISTERS</b> .
1	1	All successive read operations are from the <b>STATUS REGISTER</b> .

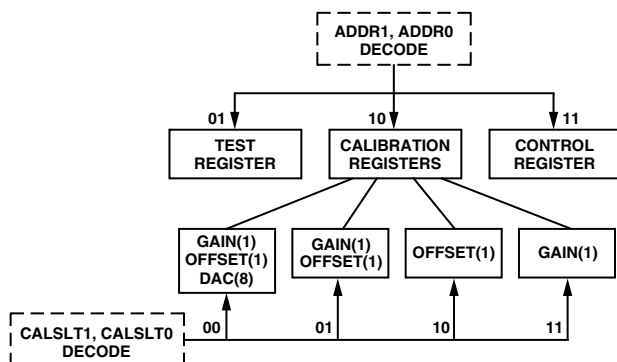

Figure 2. Write Register Hierarchy/Address Decoding

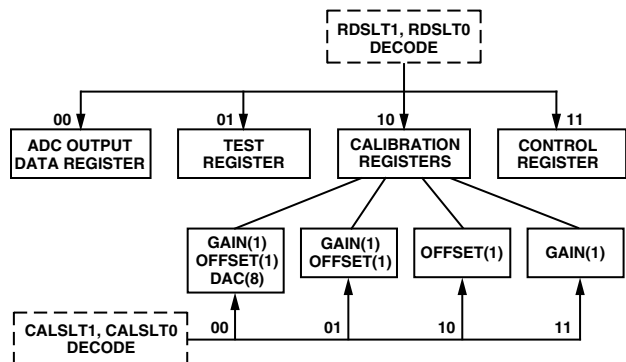
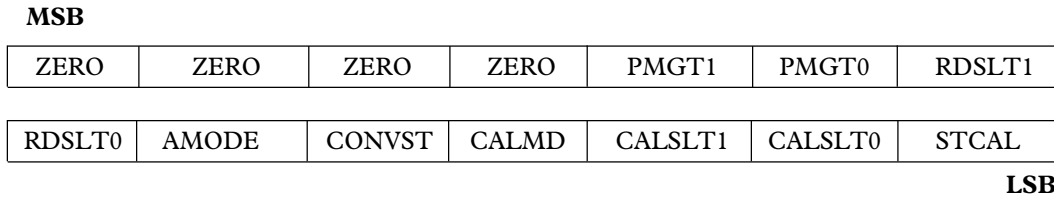

Figure 3. Read Register Hierarchy/Address Decoding



## CONTROL REGISTER

The arrangement of the control register is shown below. The control register is a write only register and contains 14 bits of data. The control register is selected by putting two 1s in ADDR1 and ADDR0. The function of the bits in the control register is described below. The power-up status of all bits is 0.



### Control Register Bit Function Description

Bit	Mnemonic	Comment
13	ZERO	These four bits must be set to 0 when writing to the control register.
12	ZERO	
11	ZERO	
10	ZERO	
9	PMGT1	Power Management Bits. These two bits are used for putting the part into various power-down modes (See <i>Power-Down</i> section for more details).
8	PMGT0	
7	RDSLT1	These two bits determine which register is addressed for the read operations. See Table II.
6	RDSLT0	
5	AMODE	Analog Mode Bit. This pin allows two different analog input ranges to be selected. A logic 0 in this bit position selects range 0 to $V_{REF}$ (i.e., $A_{IN}(+) - A_{IN}(-) = 0$ to $V_{REF}$ ). In this range $A_{IN}(+)$ cannot go below $A_{IN}(-)$ and $A_{IN}(-)$ cannot go below AGND and data coding is straight binary. A logic 1 in this bit position selects range $-V_{REF}/2$ to $+V_{REF}/2$ (i.e., $A_{IN}(+) - A_{IN}(-) = -V_{REF}/2$ to $+V_{REF}/2$ ). $A_{IN}(+)$ cannot go below AGND, so for this range, $A_{IN}(-)$ needs to be biased to at least $+V_{REF}/2$ to allow $A_{IN}(+)$ to go as low as $A_{IN}(-) - V_{REF}/2$ V. Data coding is twos complement for this range.
4	CONVST	Conversion Start Bit. A logic one in this bit position starts a single conversion, and this bit is automatically reset to 0 at the end of conversion. This bit may also be used in conjunction with system calibration (see Calibration section).
3	CALMD	Calibration Mode Bit. A 0 here selects self-calibration and a 1 selects a system calibration (see Table III).
2	CALSLT1	Calibration Selection Bits and Start Calibration Bit. These bits have two functions. With the STCAL bit set to 1, the CALSLT1 and CALSLT0 bits determine the type of calibration performed by the part (see Table III). The STCAL bit is automatically reset to 0 at the end of calibration. With the STCAL bit set to 0, the CALSLT1 and CALSLT0 bits are decoded to address the calibration register for read/write of calibration coefficients (see section on the calibration registers for more details).
1	CALSLT0	
0	STCAL	

**Table III. Calibration Selection**

CALMD	CALSLT1	CALSLT0	Calibration Type
0	0	0	A <b>full internal calibration</b> is initiated. First the internal DAC is calibrated, then the internal gain error and finally the internal offset error are removed. This is the default setting.
0	0	1	First the <b>internal gain error</b> is removed, then the <b>internal offset error</b> is removed.
0	1	0	The <b>internal offset error</b> only is calibrated out.
0	1	1	The <b>internal gain error</b> only is calibrated out.
1	0	0	A <b>full system calibration</b> is initiated. First the internal DAC is calibrated, followed by the system gain error calibration, and finally the system offset error calibration.
1	0	1	First the <b>system gain error</b> is calibrated out followed by the <b>system offset error</b> .
1	1	0	The <b>system offset error</b> only is removed.
1	1	1	The <b>system gain error</b> only is removed.

# AD7854/AD7854L

## STATUS REGISTER

The arrangement of the status register is shown below. The status register is a read-only register and contains 16 bits of data. The status register is selected by writing to the control register and putting two 1s in RDSLT1 and RDSLT0. The function of the bits in the status register are described below. The power-up status of all bits is 0.

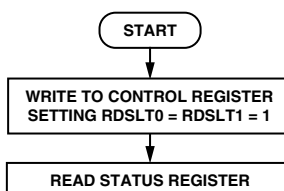

Figure 4. Flowchart for Reading the Status Register

**MSB**

ZERO	ZERO	ZERO	ZERO	ZERO	ZERO	PMGT1	PMGT0
ONE	ONE	AMODE	BUSY	CALMD	CALSLT1	CALSLT0	STCAL

**LSB**

### Status Register Bit Function Description

Bit	Mnemonic	Comment
15	ZERO	These six bits are always 0.
14	ZERO	
13	ZERO	
12	ZERO	
11	ZERO	
10	ZERO	
9	PMGT1	Power Management Bits. These bits will indicate if the part is in a power-down mode or not. See Table VI in Power-Down Section for description.
8	PMGT0	
7	ONE	Both these bits are always 1.
6	ONE	
5	AMODE	Analog Mode Bit. When this bit is a 0, the device is set up for the unipolar analog input range. When this bit is a 1, the device is set up for the bipolar analog input range.
4	BUSY	Conversion/Calibration Busy Bit. When this bit is 1, this indicates that there is a conversion or calibration in progress. When this bit is 0, there is no conversion or calibration in progress.
3	CALMD	Calibration Mode Bit. A 0 in this bit indicates a self-calibration is selected, and a 1 in this bit indicates a system calibration is selected (see Table III).
2	CALSLT1	Calibration Selection Bits and Start Calibration Bit. The STCAL bit is read as a 1 if a calibration is in progress and as a 0 if there is no calibration in progress. The CALSLT1 and CALSLT0 bits indicate which of the calibration registers are addressed for reading and writing (see section on the Calibration Registers for more details).
1	CALSLT0	
0	STCAL	

## CALIBRATION REGISTERS

The AD7854/AD7854L has 10 calibration registers in all, 8 for the DAC, 1 for offset and 1 for gain. Data can be written to or read from all 10 calibration registers. In self- and system calibration, the part automatically modifies the calibration registers; only if the user needs to modify the calibration registers should an attempt be made to read from and write to the calibration registers.

### Addressing the Calibration Registers

The calibration selection bits in the control register CALSLT1 and CALSLT0 determine which of the calibration registers are addressed (See Table IV). The addressing applies to both the read and write operations for the calibration registers. The user should not attempt to read from and write to the calibration registers at the same time.

**Table IV. Calibration Register Addressing**

CALSLT1	CALSLT0	Comment
0	0	This combination addresses the <b>Gain (1), Offset (1) and DAC Registers (8)</b> . Ten registers in total.
0	1	This combination addresses the <b>Gain (1) and Offset (1)</b> Registers. Two registers in total.
1	0	This combination addresses the <b>Offset Register</b> . One register in total.
1	1	This combination addresses the <b>Gain Register</b> . One register in total.

### Writing to/Reading from the Calibration Registers

When writing to the calibration registers a write to the control register is required to set the CALSLT0 and CALSLT1 bits. When reading from the calibration registers a write to the control register is required to set the CALSLT0 and CALSLT1 bits and also to set the RDSLTL1 and RDSLTL0 bits to 10 (this addresses the calibration registers for reading). The calibration register pointer is reset on writing to the control register setting the CALSLT1 and CALSLT0 bits, or upon completion of all the calibration register write/read operations. When reset it points to the first calibration register in the selected write/read sequence. The calibration register pointer points to the gain calibration register upon reset in all but one case, this case being where the offset calibration register is selected on its own (CALSLT1 = 1, CALSLT0 = 0). Where more than one calibration register is being accessed, the calibration register pointer is automatically incremented after each full calibration register write/read operation. The calibration register address pointer is incremented after the high byte read or write operation in byte mode. Therefore when reading from or writing to the calibration registers, the low byte transfer must be carried out first, i.e., HBEN is at logic zero. The order in which the 10 calibration registers are arranged is shown in Figure 5. Read/Write operations may be aborted at any time before all the calibration registers have been accessed, and the next control register write operation resets the calibration register pointer. The flowchart in Figure 6 shows the sequence for writing to the calibration registers. Figure 7 shows the sequence for reading from the calibration registers.

When reading from the calibration registers there are always two leading zeros for each of the registers.

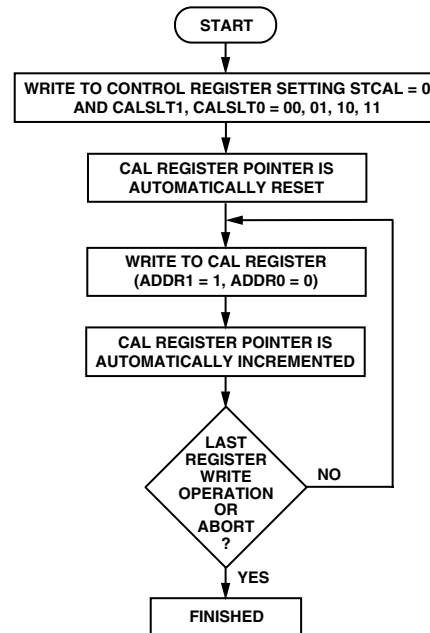

Figure 6. Flowchart for Writing to the Calibration Registers

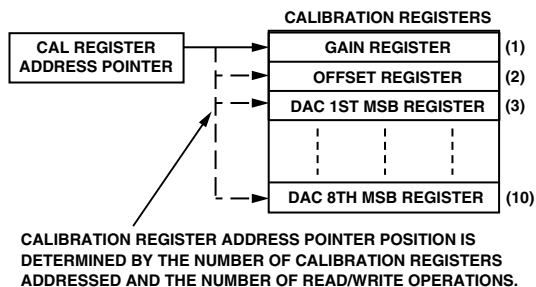

Figure 5. Calibration Register Arrangement

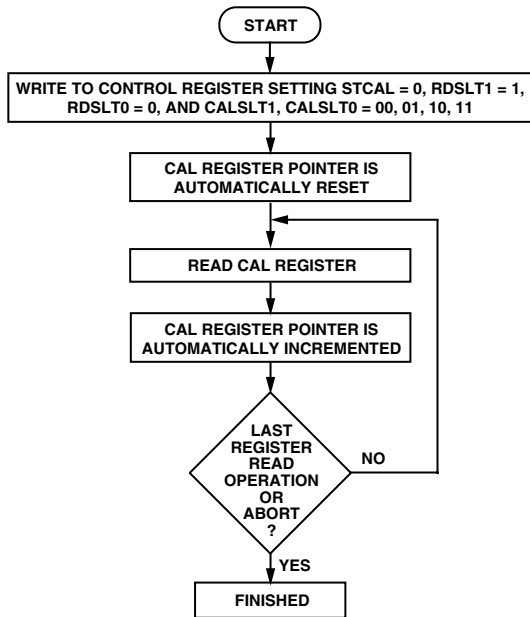

Figure 7. Flowchart for Reading from the Calibration Registers

#### Adjusting the Offset Calibration Register

The offset calibration register contains 16 bits. The two MSBs are zero and the 14 LSBs contain offset data. By changing the contents of the offset register, different amounts of offset on the analog input signal can be compensated for. Decreasing the number in the offset calibration register compensates for negative offset on the analog input signal, and increasing the number in the offset calibration register compensates for positive offset on the analog input signal. The default value of the offset calibration register is 0010 0000 0000 0000 approximately. This is not the exact value, but the value in the offset register should be close to this value. Each of the 14 data bits in the offset register is binary weighted; the MSB has a weighting of 5% of the reference voltage, the MSB-1 has a weighting of 2.5%, the MSB-2

has a weighting of 1.25%, and so on down to the LSB which has a weighting of 0.0006%. This gives a resolution of  $\pm 0.0006\%$  of  $V_{REF}$  approximately. The resolution can also be expressed as  $\pm (0.05 \times V_{REF})/2^{13}$  volts. This equals  $\pm 0.015$  mV, with a 2.5 V reference. The maximum offset that can be compensated for is  $\pm 5\%$  of the reference voltage, which equates to  $\pm 125$  mV with a 2.5 V reference and  $\pm 250$  mV with a 5 V reference.

- Q. If a +20 mV offset is present in the analog input signal and the reference voltage is 2.5 V, what code needs to be written to the offset register to compensate for the offset ?
- A. 2.5 V reference implies that the resolution in the offset register is  $5\% \times 2.5 \text{ V}/2^{13} = 0.015$  mV.  $+20 \text{ mV}/0.015 \text{ mV} = 1310.72$ ; rounding to the nearest number gives 1311. In binary terms this is 00 0101 0001 1111, therefore increase the offset register by 00 0101 0001 1111.

This method of compensating for offset in the analog input signal allows for fine tuning the offset compensation. If the offset on the analog input signal is known, there is no need to apply the offset voltage to the analog input pins and do a system calibration. The offset compensation can take place in software.

#### Adjusting the Gain Calibration Register

The gain calibration register contains 16 bits. The two MSBs are zero and the 14 LSBs contain gain data. As in the offset calibration register the data bits in the gain calibration register are binary weighted, with the MSB having a weighting of 2.5% of the reference voltage. The gain register value is effectively multiplied by the analog input to scale the conversion result over the full range. Increasing the gain register compensates for a smaller analog input range and decreasing the gain register compensates for a larger input range. The maximum analog input range that the gain register can compensate for is 1.025 times the reference voltage, and the minimum input range is 0.975 times the reference voltage.

## CIRCUIT INFORMATION

The AD7854/AD7854L is a fast, 12-bit single supply A/D converter. The part requires an external 4 MHz/1.8 MHz master clock (CLKIN), two  $C_{REF}$  capacitors, a  $\overline{CONVST}$  signal to start conversion and power supply decoupling capacitors. The part provides the user with track/hold, on-chip reference, calibration features, A/D converter and parallel interface logic functions on a single chip. The A/D converter section of the AD7854/AD7854L consists of a conventional successive-approximation converter based around a capacitor DAC. The AD7854/AD7854L accepts an analog input range of 0 to  $+V_{REF}$ .  $V_{REF}$  can be tied to  $V_{DD}$ . The reference input to the part connected via a 150 k $\Omega$  resistor to the internal 2.5 V reference and to the on-chip buffer.

A major advantage of the AD7854/AD7854L is that a conversion can be initiated in software as well as applying a signal to the  $\overline{CONVST}$  pin. The part is available in a 28-Lead SSOP package, and this offers the user considerable space saving advantages over alternative solutions. The AD7854L version typically consumes only 5.5 mW making it ideal for battery-powered applications.

## CONVERTER DETAILS

The master clock for the part is applied to the CLKIN pin. Conversion is initiated on the AD7854/AD7854L by pulsing the  $\overline{CONVST}$  input or by writing to the control register and setting the CONVST bit to 1. On the rising edge of  $\overline{CONVST}$  (or at the end of the control register write operation), the on-chip track/hold goes from track to hold mode. The falling edge of the CLKIN signal which follows the rising edge of  $\overline{CONVST}$  initiates the conversion, provided the rising edge of  $\overline{CONVST}$  (or  $\overline{WR}$  when converting via the control register) occurs typically at least 10 ns before this CLKIN edge. The conversion takes 16.5 CLKIN periods from this CLKIN falling edge. If the 10 ns setup time is not met, the conversion takes 17.5 CLKIN periods.

The time required by the AD7854/AD7854L to acquire a signal depends upon the source resistance connected to the AIN(+) input. Please refer to the Acquisition Time section for more details.

When a conversion is completed, the BUSY output goes low, and the result of the conversion can be read by accessing the data through the data bus. To obtain optimum performance from the part, read or write operations should not occur during the conversion or less than 200 ns prior to the next  $\overline{CONVST}$  rising edge. Reading/writing during conversion typically degrades the Signal to (Noise + Distortion) by less than 0.5 dBs. The AD7854 can operate at throughput rates of over 200 kSPS (up to 100 kSPS for the AD7854L).

With the AD7854L, 100 kSPS throughput can be obtained as follows: the CLKIN and  $\overline{CONVST}$  signals are arranged to give a conversion time of 16.5 CLKIN periods as described above and 1.5 CLKIN periods are allowed for the acquisition time. With a 1.8 MHz clock, this gives a full cycle time of 10  $\mu$ s, which equates to a throughput rate of 100 kSPS.

When using the software conversion start for maximum throughput, the user must ensure the control register write operation extends beyond the falling edge of BUSY. The falling edge of BUSY resets the  $\overline{CONVST}$  bit to 0 and allows it to be reprogrammed to 1 to start the next conversion.

## TYPICAL CONNECTION DIAGRAM

Figure 8 shows a typical connection diagram for the AD7854/AD7854L. The AGND and the DGND pins are connected together at the device for good noise suppression. The first  $\overline{CONVST}$  applied after power-up starts a self-calibration sequence. This is explained in the *calibration* section of the data sheet. Applying the  $\overline{RD}$  and CS signals causes the conversion result to be output on the 12 data pins. Note that after power is applied to  $AV_{DD}$  and  $DV_{DD}$ , and the  $\overline{CONVST}$  signal is applied, the part requires (70 ms + 1/sample rate) for the internal reference to settle and for the self-calibration to be completed.

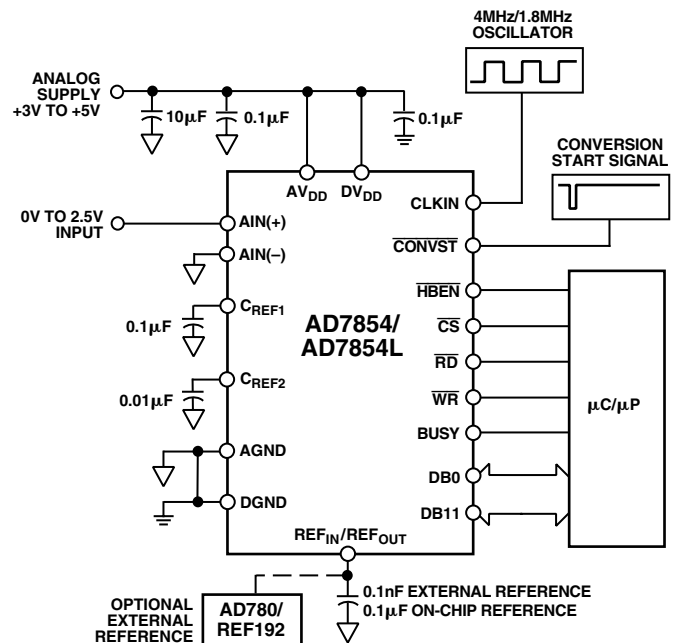

Figure 8. Typical Circuit

For applications where power consumption is a major concern, the power-down options can be programmed by writing to the part. See Power-Down section for more detail on low power applications.

# AD7854/AD7854L

## ANALOG INPUT

The equivalent analog input circuit is shown in Figure 9. During the acquisition interval the switches are both in the track position and the AIN(+) charges the 20 pF capacitor through the 125 Ω resistance. On the rising edge of  $\overline{\text{CONVST}}$  switches SW1 and SW2 go into the hold position retaining charge on the 20 pF capacitor as a sample of the signal on AIN(+). The AIN(-) is connected to the 20 pF capacitor, and this unbalances the voltage at Node A at the input of the comparator. The capacitor DAC adjusts during the remainder of the conversion cycle to restore the voltage at Node A to the correct value. This action transfers a charge, representing the analog input signal, to the capacitor DAC which in turn forms a digital representation of the analog input signal. The voltage on the AIN(-) pin directly influences the charge transferred to the capacitor DAC at the hold instant. If this voltage changes during the conversion period, the DAC representation of the analog input voltage is altered. Therefore it is most important that the voltage on the AIN(-) pin remains constant during the conversion period. Furthermore, it is recommended that the AIN(-) pin is always connected to AGND or to a fixed dc voltage.

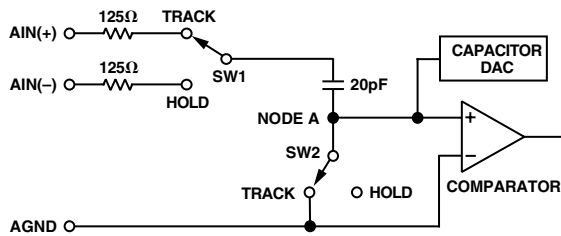

Figure 9. Analog Input Equivalent Circuit

### Acquisition Time

The track-and-hold amplifier enters its tracking mode on the falling edge of the BUSY signal. The time required for the track-and-hold amplifier to acquire an input signal depends on how quickly the 20 pF input capacitance is charged. There is a minimum acquisition time of 400 ns. For large source impedances, >2 kΩ, the acquisition time is calculated using the formula:

$$t_{ACQ} = 9 \times (R_{IN} + 125 \Omega) \times 20 \text{ pF}$$

where  $R_{IN}$  is the source impedance of the input signal, and 125 Ω, 20 pF is the input R, C.

### DC/AC Applications

For dc applications, high source impedances are acceptable, provided there is enough acquisition time between conversions to charge the 20 pF capacitor. For example with  $R_{IN} = 5 \text{ k}\Omega$ , the required acquisition time is 922 ns.

For ac applications, removing high frequency components from the analog input signal is recommended by use of an RC low-pass filter on the AIN(+) pin, as shown in Figure 11. In applications where harmonic distortion and signal to noise ratio are critical, the analog input should be driven from a low impedance source. Large source impedances significantly affect the ac performance of the ADC. They may require the use of an input buffer amplifier. The choice of the amplifier is a function of the particular application.

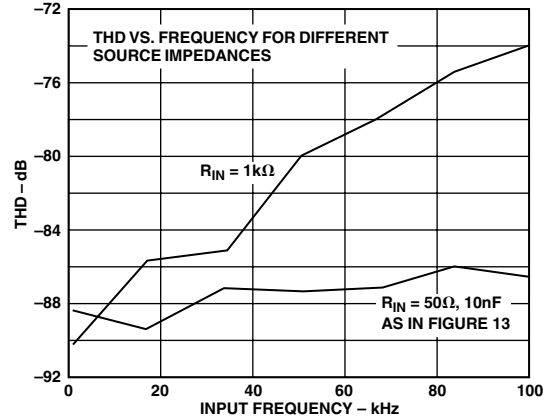

Figure 10. THD vs. Analog Input Frequency

The maximum source impedance depends on the amount of total harmonic distortion (THD) that can be tolerated. The THD increases as the source impedance increases. Figure 10 shows a graph of the total harmonic distortion vs. analog input signal frequency for different source impedances. With the setup as in Figure 11, the THD is at the -90 dB level. With a source impedance of 1 kΩ and no capacitor on the AIN(+) pin, the THD increases with frequency.

In a single supply application (both 3 V and 5 V), the V+ and V- of the op amp can be taken directly from the supplies to the AD7854/AD7854L which eliminates the need for extra external power supplies. When operating with rail-to-rail inputs and outputs at frequencies greater than 10 kHz, care must be taken in selecting the particular op amp for the application. In particular, for single supply applications the input amplifiers should be connected in a gain of -1 arrangement to get the optimum performance. Figure 11 shows the arrangement for a single supply application with a 50 Ω and 10 nF low-pass filter (cutoff frequency 320 kHz) on the AIN(+) pin. Note that the 10 nF is a capacitor with good linearity to ensure good ac performance. Recommended single supply op amps are the AD820 and the AD820-3V.

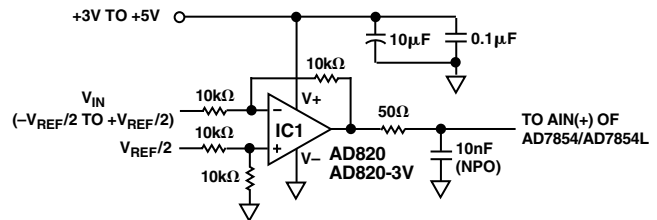

Figure 11. Analog Input Buffering

## Input Ranges

The analog input range for the AD7854/AD7854L is 0 V to  $V_{REF}$  in both the unipolar and bipolar ranges.

The only difference between the unipolar range and the bipolar range is that in the bipolar range the  $A_{IN}(-)$  should be biased up to at least  $+V_{REF}/2$  and the output coding is twos complement (see Table V and Figures 14 and 15).

**Table V. Analog Input Connections**

Analog Input Range	Input Connections		Connection Diagram
	$A_{IN}(+)$	$A_{IN}(-)$	
0 V to $V_{REF}$ <sup>1</sup>	$V_{IN}$	AGND	Figure 12
$\pm V_{REF}/2$ <sup>2</sup>	$V_{IN}$	$V_{REF}/2$	Figure 13

**NOTES**

<sup>1</sup>Output code format is straight binary.

<sup>2</sup>Range is  $\pm V_{REF}/2$  biased about  $V_{REF}/2$ . Output code format is twos complement.

Note that the  $A_{IN}(-)$  pin on the AD7854/AD7854L can be biased up above AGND in the unipolar mode, or above  $V_{REF}/2$  in bipolar mode if required. The advantage of biasing the lower end of the analog input range away from AGND is that the analog input does not have to swing all the way down to AGND. Thus, in single supply applications the input amplifier does not have to swing all the way down to AGND. The upper end of the analog input range is shifted up by the same amount. Care must be taken so that the bias applied does not shift the upper end of the analog input above the  $AV_{DD}$  supply. In the case where the reference is the supply,  $AV_{DD}$ , the  $A_{IN}(-)$  should be tied to AGND in unipolar mode or to  $AV_{DD}/2$  in bipolar mode.

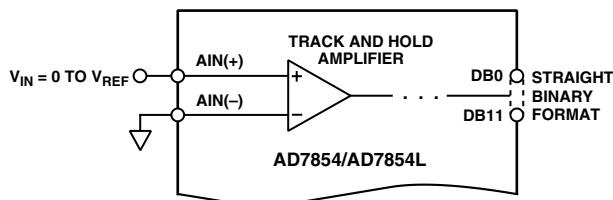

Figure 12. 0 to  $V_{REF}$  Unipolar Input Configuration

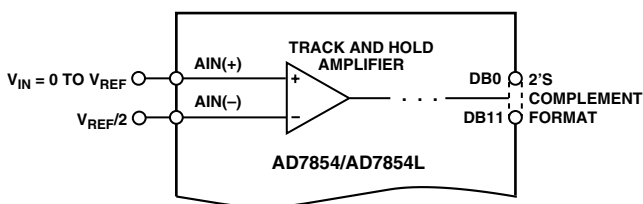

Figure 13.  $\pm V_{REF}/2$  about  $V_{REF}/2$  Bipolar Input Configuration

## Transfer Functions

For the unipolar range the designed code transitions occur midway between successive integer LSB values (i.e.,  $1/2$  LSB,  $3/2$  LSBs,  $5/2$  LSBs . . .  $FS - 3/2$  LSBs). The output coding is straight binary for the unipolar range with  $1 \text{ LSB} = FS/4096 = 3.3 \text{ V}/4096 = 0.8 \text{ mV}$  when  $V_{REF} = 3.3 \text{ V}$ . The ideal input/output transfer characteristic for the unipolar range is shown in Figure 14.

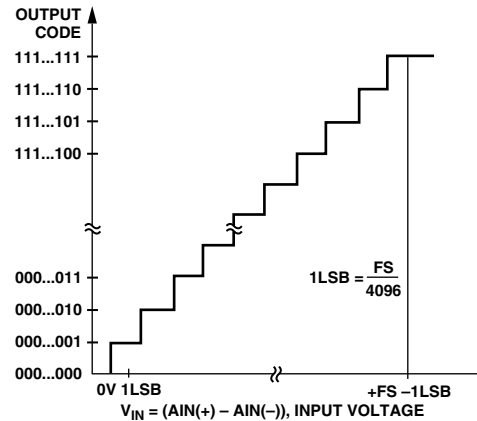

Figure 14. AD7854/AD7854L Unipolar Transfer Characteristic

Figure 13 shows the AD7854/AD7854L's  $\pm V_{REF}/2$  bipolar analog input configuration.  $A_{IN}(+)$  cannot go below 0 V, so for the full bipolar range,  $A_{IN}(-)$  should be biased to at least  $+V_{REF}/2$ . Once again the designed code transitions occur midway between successive integer LSB values. The output coding is twos complement with  $1 \text{ LSB} = FS/4096 = 3.3 \text{ V}/4096 = 0.8 \text{ mV}$ . The ideal input/output transfer characteristic is shown in Figure 15.

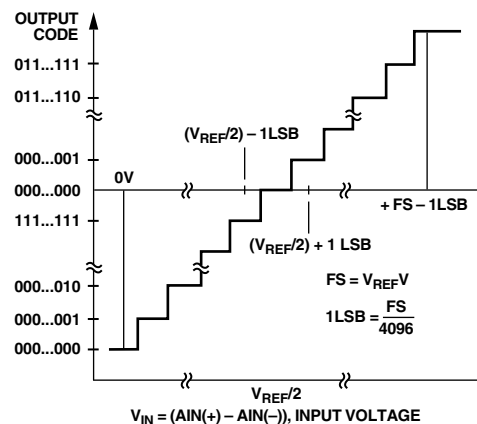

Figure 15. AD7854/AD7854L Bipolar Transfer Characteristic

# AD7854/AD7854L

## REFERENCE SECTION

For specified performance, it is recommended that when using an external reference, this reference should be between 2.3 V and the analog supply  $AV_{DD}$ . The connections for the reference pins are shown below. If the internal reference is being used, the  $REF_{IN}/REF_{OUT}$  pin should be decoupled with a 100 nF capacitor to AGND very close to the  $REF_{IN}/REF_{OUT}$  pin. These connections are shown in Figure 16.

If the internal reference is required for use external to the ADC, it should be buffered at the  $REF_{IN}/REF_{OUT}$  pin and a 100 nF capacitor should be connected from this pin to AGND. The typical noise performance for the internal reference, with 5 V supplies is  $150 \text{ nV}/\sqrt{\text{Hz}}$  @ 1 kHz and dc noise is 100  $\mu\text{V}$  p-p.

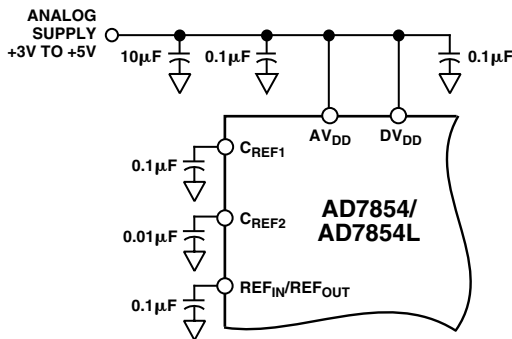

Figure 16. Relevant Connections Using Internal Reference

The  $REF_{IN}/REF_{OUT}$  pin may be overdriven by connecting it to an external reference. This is possible due to the series resistance from the  $REF_{IN}/REF_{OUT}$  pin to the internal reference. This external reference can be in the range 2.3 V to  $AV_{DD}$ . When using  $AV_{DD}$  as the reference source, the 10 nF capacitor from the  $REF_{IN}/REF_{OUT}$  pin to AGND should be as close as possible to the  $REF_{IN}/REF_{OUT}$  pin, and also the  $C_{REF1}$  pin should be connected to  $AV_{DD}$  to keep this pin at the same voltage as the reference. The connections for this arrangement are shown in Figure 17. When using  $AV_{DD}$  it may be necessary to add a resistor in series with the  $AV_{DD}$  supply. This has the effect of filtering the noise associated with the  $AV_{DD}$  supply.

Note that when using an external reference, the voltage present at the  $REF_{IN}/REF_{OUT}$  pin is determined by the external reference source resistance and the series resistance of 150 k $\Omega$  from the  $REF_{IN}/REF_{OUT}$  pin to the internal 2.5 V reference. Thus, a low source impedance external reference is recommended.

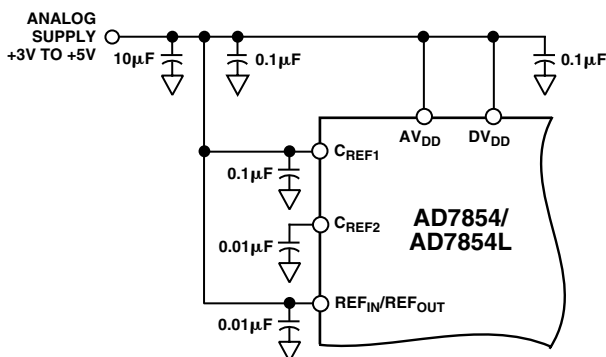

Figure 17. Relevant Connections,  $AV_{DD}$  as the Reference

## AD7854/AD7854L PERFORMANCE CURVES

Figure 18 shows a typical FFT plot for the AD7854 at 200 kHz sample rate and 10 kHz input frequency.

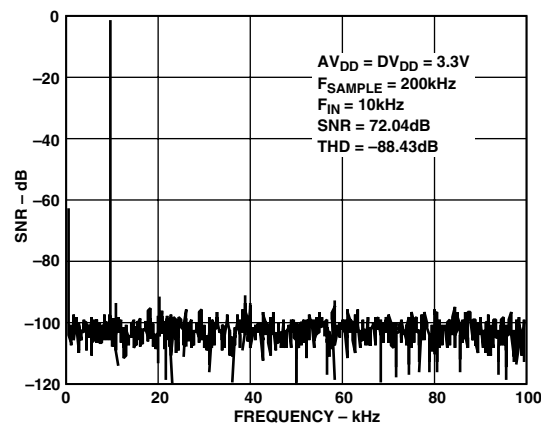

Figure 18. FFT Plot

Figure 19 shows the SNR versus frequency for different supplies and different external references.

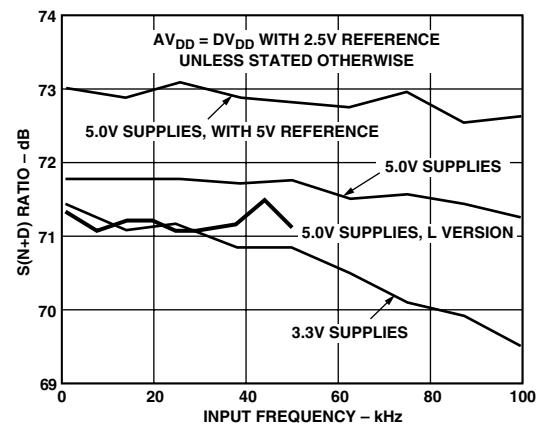

Figure 19. SNR vs. Frequency

Figure 20 shows the power supply rejection ratio versus frequency for the part. The power supply rejection ratio is defined as the ratio of the power in ADC output at frequency  $f$  to the power of a full-scale sine wave:

$$PSRR \text{ (dB)} = 10 \log (P_f/P_{fs})$$

$P_f$  = Power at frequency  $f$  in ADC output,  $P_{fs}$  = power of a full-scale sine wave. Here a 100 mV peak-to-peak sine wave is coupled onto the  $AV_{DD}$  supply while the digital supply is left unaltered. Both the 3.3 V and 5.0 V supply performances are shown.



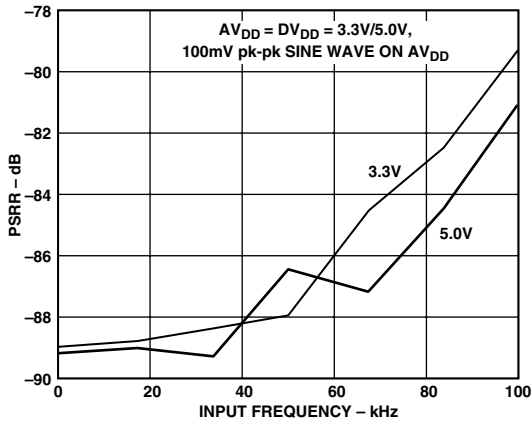

Figure 20. PSRR vs. Frequency

### POWER-DOWN OPTIONS

The AD7854/AD7854L provides flexible power management to allow the user to achieve the best power performance for a given throughput rate. The power management options are selected by programming the power management bits, PMGT1 and PMGT0, in the control register. Table VI summarizes the power-down options that are available and how they can be selected by programming the power management bits in the control register.

The AD7854/AD7854L can be fully or partially powered down. When fully powered down, all the on-chip circuitry is powered down and  $I_{DD}$  is 10  $\mu$ A typ. If a partial power-down is selected, then all the on-chip circuitry except the reference is powered down and  $I_{DD}$  is 400  $\mu$ A typ with the external clock running. Additional power savings may be made if the external clock is off.

The choice of full or partial power-down does not give any significant improvement in the throughput rate which can be achieved with a power-down between conversions. This is discussed in the next section—*Power-Up Times*. But a partial power-down does allow the on-chip reference to be used externally even though the rest of the AD7854/AD7854L circuitry is powered down. It also allows the AD7854/AD7854L to be powered up faster after a long power-down period when using the on-chip reference (See *Power-Up Times* section—*Using the Internal (On-Chip) Reference*).

As can be seen from Table VI, the AD7854/AD7854L can be programmed for normal operation, a full power-down at the end of a conversion, a partial power-down at the end of a conversion and finally a full power-down whether converting or not. The full and partial power-down at the end of a conversion can be used to achieve a superior power performance at slower throughput rates, in the order of 50 kSPS (see *Power vs. Throughput Rate* section of this data sheet).

Table VI. Power Management Options

PMGT1 Bit	PMGT0 Bit	Comment
0	0	Normal Operation
0	1	Full Power-Down After a Conversion
1	0	Full Power-Down
1	1	Partial Power-Down After a Conversion

### POWER-UP TIMES

#### Using an External Reference

When the AD7854/AD7854L are powered up, the parts are powered up from one of two conditions. First, when the power supplies are initially powered up and, secondly, when the parts are powered up from a software power-down (see last section).

When  $AV_{DD}$  and  $DV_{DD}$  are powered up, the AD7854/AD7854L enters a mode whereby the  $\overline{CONVST}$  signal initiates a timeout followed by a self-calibration. The total time taken for this timeout and calibration is approximately 70 ms—see *Calibration on Power-Up* in the calibration section of this data sheet. The power-up calibration mode can be disabled if the user writes to the control register before a  $\overline{CONVST}$  signal is applied. If the timeout and self-calibration are disabled, then the user must take into account the time required by the AD7854/AD7854L to power up before a self-calibration is carried out. This power-up time is the time taken for the AD7854/AD7854L to power up when power is first applied (300  $\mu$ s typ) or the time it takes the external reference to settle to the 12-bit level—whichever is the longer.

The AD7854/AD7854L powers up from a full software power-down in 5  $\mu$ s typ. This limits the throughput which the part is capable of to 100 kSPS for the AD7854 and 60 kSPS for the AD7854L when powering down between conversions. Figure 21 shows how a full power-down between conversions is implemented using the  $\overline{CONVST}$  pin. The user first selects the power-down between conversions option by setting the power management bits, PMGT1 and PMGT0, to 0 and 1 respectively in the control register (see last section). In this mode the AD7854/AD7854L automatically enters a full power-down at the end of a conversion, i.e., when  $BUSY$  goes low. The falling edge of the next  $\overline{CONVST}$  pulse causes the part to power up. Assuming the external reference is left powered up, the AD7854/AD7854L should be ready for normal operation 5  $\mu$ s after this falling edge. The rising edge of  $\overline{CONVST}$  initiates a conversion so the  $\overline{CONVST}$  pulse should be at least 5  $\mu$ s wide. The part automatically powers down on completion of the conversion. Where the software convert start is used, the part may be powered up in software before a conversion is initiated.

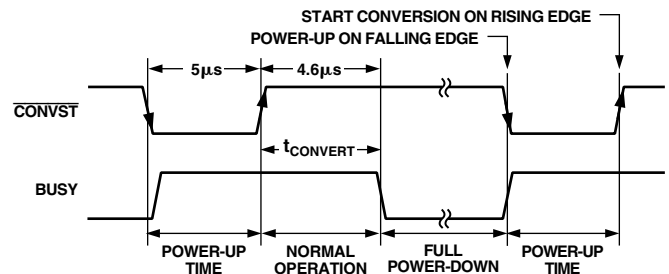

Figure 21. Using the  $\overline{CONVST}$  Pin to Power Up the AD7854 for a Conversion

# AD7854/AD7854L

## Using The Internal (On-Chip) Reference

As in the case of an external reference the AD7854/AD7854L can power up from one of two conditions, power-up after the supplies are connected or power-up from a software power-down.

When using the on-chip reference and powering up when  $AV_{DD}$  and  $DV_{DD}$  are first connected, it is recommended that the power-up calibration mode be disabled as explained above. When using the on-chip reference, the power-up time is effectively the time it takes to charge up the external capacitor on the  $REF_{IN}/REF_{OUT}$  pin. This time is given by the equation:

$$t_{UP} = 9 \times R \times C$$

where  $R \approx 150K$  and  $C$  = external capacitor.

The recommended value of the external capacitor is 100 nF; this gives a power-up time of approximately 135 ms before a calibration is initiated and normal operation should commence.

When  $C_{REF}$  is fully charged, the power-up time from a software power-down reduces to 5  $\mu$ s. This is because an internal switch opens to provide a high impedance discharge path for the reference capacitor during power-down—see Figure 22. An added advantage of the low charge leakage from the reference capacitor during power-down is that even though the reference is being powered down between conversions, the reference capacitor holds the reference voltage to within 0.5 LSBs with throughput rates of 100 samples/second and over with a full power-down between conversions. A high input impedance op amp like the AD707 should be used to buffer this reference capacitor if it is being used externally. Note, if the AD7854/AD7854L is left in its powered-down state for more than 100 ms, the charge on  $C_{REF}$  will start to leak away and the power-up time will increase. If this longer power-up time is a problem, the user can use a partial power-down for the last conversion so the reference remains powered up.

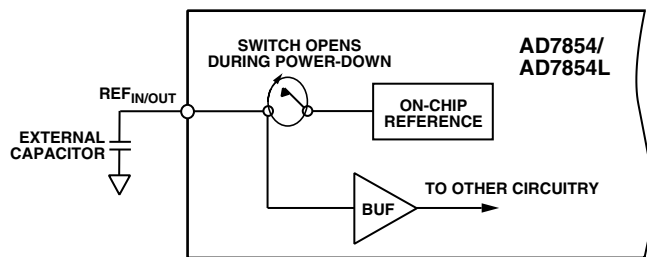

Figure 22. On-Chip Reference During Power-Down

## POWER VS. THROUGHPUT RATE

The main advantage of a full power-down after a conversion is that it significantly reduces the power consumption of the part at lower throughput rates. When using this mode of operation, the AD7854/AD7854L is only powered up for the duration of the conversion. If the power-up time of the AD7854/AD7854L is taken to be 5  $\mu$ s and it is assumed that the current during power-up is 4.5 mA/1.5 mA typ, then power consumption as a function of throughput can easily be calculated. The AD7854 has a conversion time of 4.6  $\mu$ s with a 4 MHz external clock, and the AD7854L has a conversion time of 9  $\mu$ s with a 1.8 MHz clock. This means the AD7854/AD7854L consumes 4.5 mA/1.5 mA typ for 9.6  $\mu$ s/14  $\mu$ s in every conversion cycle if the parts are powered down at the end of a conversion. The four graphs, Figures 24, 25, 26 and 27, show the power consumption of the AD7854 and AD7854L for  $V_{DD} = 3V$  as a function of throughput. Table VII lists the power consumption for various throughput rates.

Table VII. Power Consumption vs. Throughput

Throughput Rate	Power AD7854	Power AD7854L
1 kSPS	130 $\mu$ W	65 $\mu$ W
10 kSPS	1.3 mW	650 $\mu$ W
20 kSPS	2.6 mW	1.25 mW
50 kSPS	6.48 mW	3.2 mW

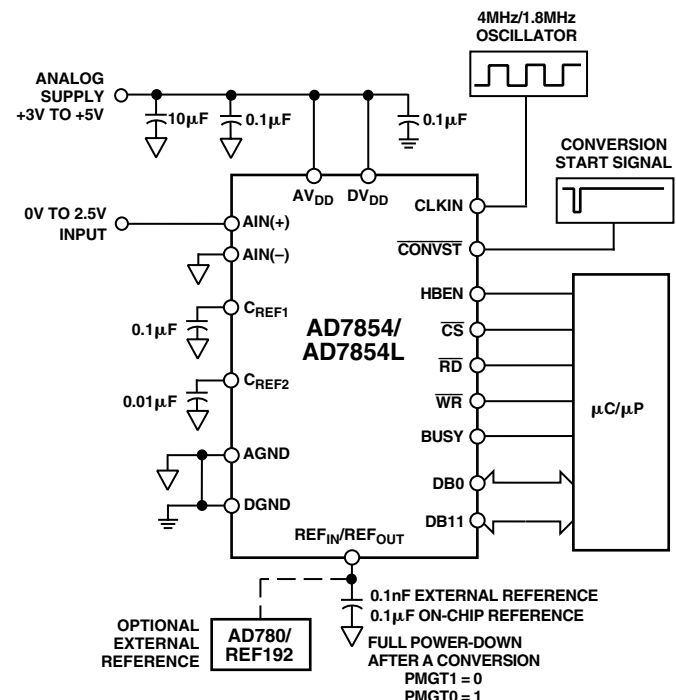

Figure 23. Typical Low Power Circuit

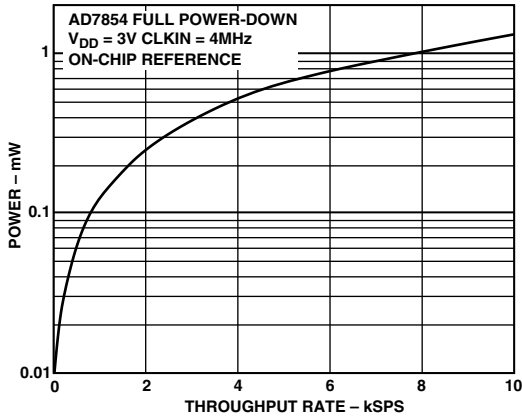

Figure 24. Power vs. Throughput AD7854

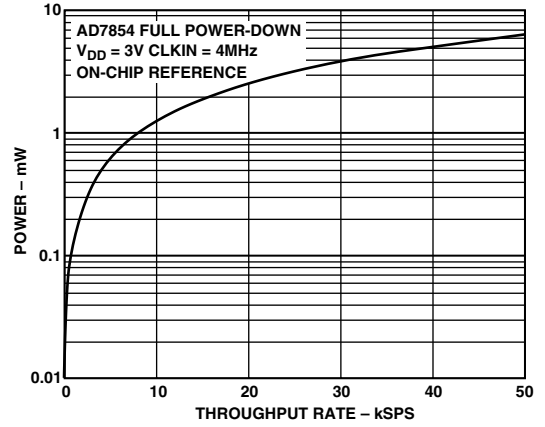

Figure 26. Power vs. Throughput AD7854

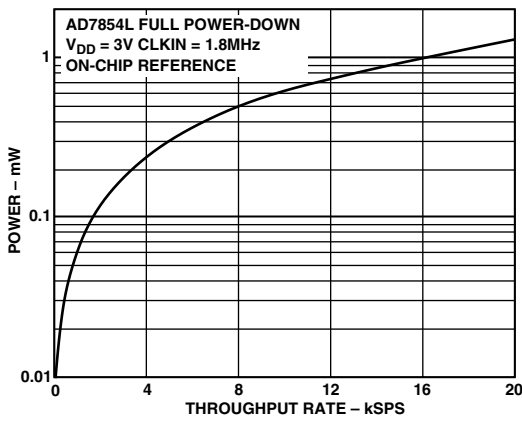

Figure 25. Power vs. Throughput AD7854L

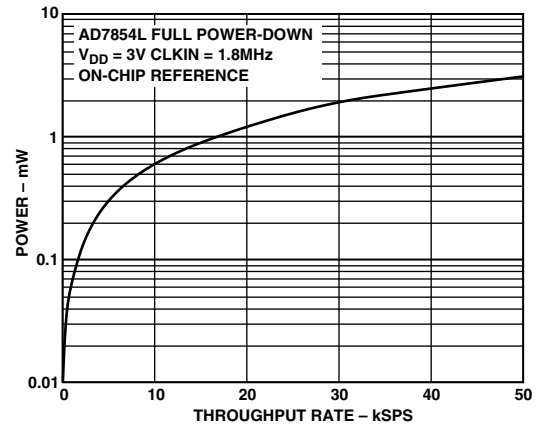

Figure 27. Power vs. Throughput AD7854L

# AD7854/AD7854L

## CALIBRATION SECTION

### Calibration Overview

The automatic calibration that is performed on power-up ensures that the calibration options covered in this section are not required in a significant number of applications. A calibration does not have to be initiated unless the operating conditions change (CLKIN frequency, analog input mode, reference voltage, temperature, and supply voltages). The AD7854/AD7854L has a number of calibration features that may be required in some applications, and there are a number of advantages in performing these different types of calibration. First, the internal errors in the ADC can be reduced significantly to give superior dc performance; and second, system offset and gain errors can be removed. This allows the user to remove reference errors (whether it be internal or external reference) and to make use of the full dynamic range of the AD7854/AD7854L by adjusting the analog input range of the part for a specific system.

There are two main calibration modes on the AD7854/AD7854L, self-calibration and system calibration. There are various options in both self-calibration and system calibration as outlined previously in Table III. All the calibration functions are initiated by writing to the control register and setting the STCAL bit to 1.

The duration of each of the different types of calibration is given in Table IX for the AD7854 with a 4 MHz master clock. These calibration times are master clock dependent. Therefore the calibration times for the AD7854L (CLKIN = 1.8 MHz) are larger than those quoted in Table VIII.

**Table VIII. Calibration Times (AD7854 with 4 MHz CLKIN)**

Type of Self-Calibration or System Calibration	Time
Full	31.25 ms
Gain + Offset	6.94 ms
Offset	3.47 ms
Gain	3.47 ms

### Automatic Calibration on Power-On

The automatic calibration on power-on is initiated by the first  $\overline{\text{CONVST}}$  pulse after the  $\text{AV}_{\text{DD}}$  and  $\text{DV}_{\text{DD}}$  power on. From the  $\overline{\text{CONVST}}$  pulse the part internally sets a 32/72 ms (4 MHz/1.8 MHz CLKIN) timeout. This time is large enough to ensure that the internal reference has settled before the calibration is performed. However, if an external reference is being used, this reference must have stabilized before the automatic calibration is initiated. This first  $\overline{\text{CONVST}}$  pulse also triggers the BUSY signal high, and once the 32/72 ms has elapsed, the BUSY signal goes low. At this point the next  $\overline{\text{CONVST}}$  pulse that is applied initiates the automatic full self-calibration. This  $\overline{\text{CONVST}}$  pulse again triggers the BUSY signal high, and after 32/72 ms (4 MHz/1.8 MHz CLKIN), the calibration is completed and the BUSY signal goes low. This timing arrangement is shown in Figure 28. The times in Figure 28 assume a 4 MHz/1.8 MHz CLKIN signal.

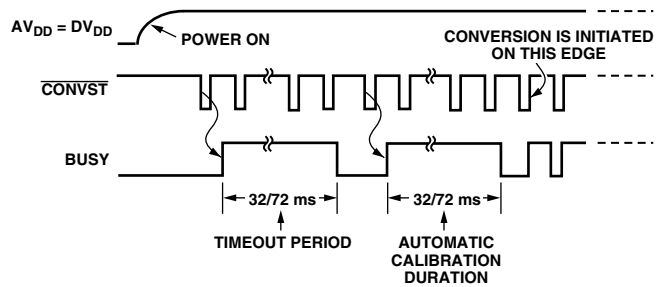

**Figure 28. Timing Arrangement for Autocalibration on Power-On**

The  $\overline{\text{CONVST}}$  signal is gated with the BUSY internally so that as soon as the timeout is initiated by the first  $\overline{\text{CONVST}}$  pulse all subsequent  $\overline{\text{CONVST}}$  pulses are ignored until the BUSY signal goes low, 32/72 ms later. The  $\overline{\text{CONVST}}$  pulse that follows after the BUSY signal goes low initiates an automatic full self-calibration. This takes a further 32/72 ms. After calibration, the part is accurate to the 12-bit level and the specifications quoted on the data sheet apply, and all subsequent  $\overline{\text{CONVST}}$  pulses initiate conversions. There is no need to perform another calibration unless the operating conditions change or unless a system calibration is required.

This autocalibration at power-on is disabled if the user writes to the control register before the autocalibration is initiated. If the control register write operation occurs during the first 32/72 ms timeout period, then the BUSY signal stays high for the 32/72 ms and the  $\overline{\text{CONVST}}$  pulse that follows the BUSY going low does not initiate an automatic full self-calibration. It initiates a conversion and all subsequent  $\overline{\text{CONVST}}$  pulses initiate conversions as well. If the control register write operation occurs when the automatic full self-calibration is in progress, then the calibration is not be aborted; the BUSY signal remains high until the automatic full self-calibration is complete.

### Self-Calibration Description

There are four different calibration options within the self-calibration mode. There is a full self-calibration where the DAC, internal offset, and internal gain errors are removed. There is the (Gain + Offset) self-calibration which removes the internal gain error and then the internal offset errors. The internal DAC is not calibrated here. Finally, there are the self-offset and self-gain calibrations which remove the internal offset errors and the internal gain errors respectively.

The internal capacitor DAC is calibrated by trimming each of the capacitors in the DAC. It is the ratio of these capacitors to each other that is critical, and so the calibration algorithm ensures that this ratio is at a specific value by the end of the calibration routine. For the offset and gain there are two separate capacitors, one of which is trimmed during offset calibration and one of which is trimmed during gain calibration.

In bipolar mode the midscale error is adjusted by an offset calibration and the positive full-scale error is adjusted by the gain calibration. In unipolar mode the zero-scale error is adjusted by the offset calibration and the positive full-scale error is adjusted by the gain calibration.

**Self-Calibration Timing**

Figure 29 shows the timing for a software full self-calibration. Here the BUSY line stays high for the full length of the self-calibration. A self-calibration is initiated by writing to the control register and setting the STCAL bit to 1. The BUSY line goes high at the end of the write to the control register, and BUSY goes low when the full self-calibration is complete after a time  $t_{CAL}$  as show in Figure 29.

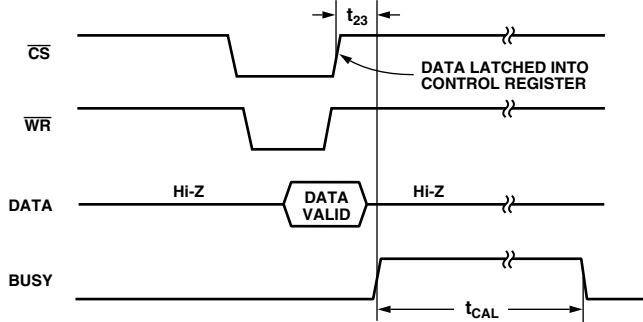

Figure 29. Timing Diagram for Full Self-Calibration

For the self-(gain + offset), self-offset and self-gain calibrations, the BUSY line is triggered high at the end of the write to the control register and stays high for the full duration of the self-calibration. The length of time for which BUSY is high depends on the type of self-calibration that is initiated. Typical values are given in Table VIII. The timing diagram for the other self-calibration options is similar to that outlined in Figure 29.

**System Calibration Description**

System calibration allows the user to remove system errors external to the AD7854/AD7854L, as well as remove the errors of the AD7854/AD7854L itself. The maximum calibration range for the system offset errors is  $\pm 5\%$  of  $V_{REF}$ , and for the system gain errors it is  $\pm 2.5\%$  of  $V_{REF}$ . If the system offset or system gain errors are outside these ranges, the system calibration algorithm reduces the errors as much as the trim range allows.

Figures 30 through 32 illustrate why a specific type of system calibration might be used. Figure 30 shows a system offset calibration (assuming a positive offset) where the analog input range has been shifted upwards by the system offset after the system offset calibration is completed. A negative offset may also be removed by a system offset calibration.

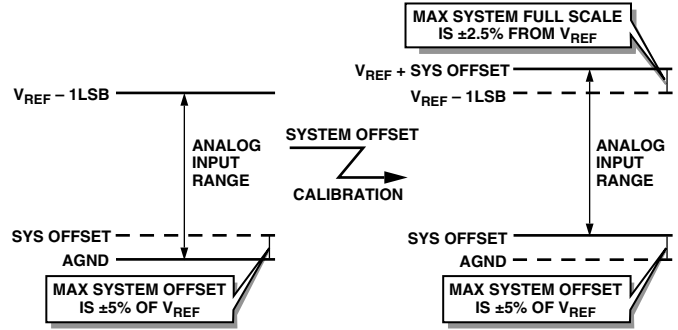

Figure 30. System Offset Calibration

Figure 31 shows a system gain calibration (assuming a system full scale greater than the reference voltage) where the analog input range has been increased after the system gain calibration is completed. A system full-scale voltage less than the reference voltage may also be accounted for a by a system gain calibration.

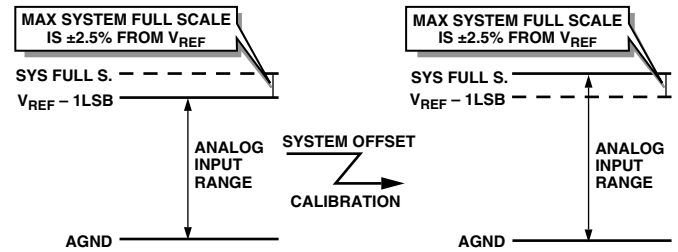

Figure 31. System Gain Calibration

Finally in Figure 32 both the system offset error and gain error are removed by the system offset followed by a system gain calibration. First the analog input range is shifted upwards by the positive system offset and then the analog input range is adjusted at the top end to account for the system full scale.

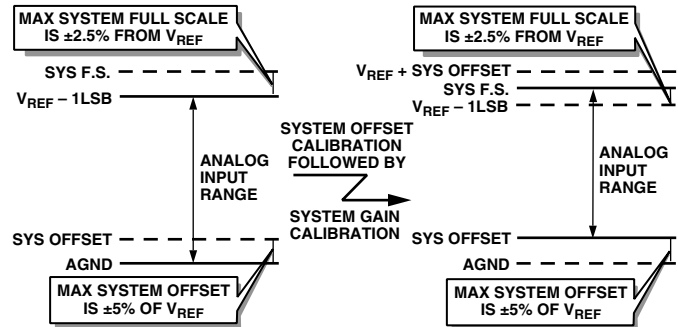

Figure 32. System (Gain + Offset) Calibration

# AD7854/AD7854L

## System Gain and Offset Interaction

The architecture of the AD7854/AD7854L leads to an interaction between the system offset and gain errors when a system calibration is performed. Therefore it is recommended to perform the cycle of a system offset calibration followed by a system gain calibration twice. When a system offset calibration is performed, the system offset error is reduced to zero. If this is followed by a system gain calibration, then the system gain error is now zero, but the system offset error is no longer zero. A second sequence of system offset error calibration followed by a system gain calibration is necessary to reduce system offset error to below the 12-bit level. The advantage of doing separate system offset and system gain calibrations is that the user has more control over when the analog inputs need to be at the required levels, and the  $\overline{\text{CONVST}}$  signal does not have to be used.

Alternatively, a system (gain + offset) calibration can be performed. At the end of one system (gain + offset) calibration, the system offset error is zero, while the system gain error is reduced from its initial value. Three system (gain + offset) calibrations are required to reduce the system gain error to below the 12-bit error level. There is never any need to perform more than three system (gain + offset) calibrations.

In bipolar mode the midscale error is adjusted for an offset calibration and the positive full-scale error is adjusted for the gain calibration; in unipolar mode the zero-scale error is adjusted for an offset calibration and the positive full-scale error is adjusted for a gain calibration.

## System Calibration Timing

The timing diagram in Figure 33 is for a software full system calibration. It may be easier in some applications to perform separate gain and offset calibrations so that the  $\overline{\text{CONVST}}$  bit in the control register does not have to be programmed in the middle of the system calibration sequence. Once the write to the control register setting the bits for a full system calibration is completed, calibration of the internal DAC is initiated and the  $\text{BUSY}$  line goes high. The full-scale system voltage should be applied to the analog input pins,  $\text{AIN}(+)$  and  $\text{AIN}(-)$  at the start of calibration. The  $\text{BUSY}$  line goes low once the DAC and system gain calibration are complete. Next the system offset voltage should be applied across the  $\text{AIN}(+)$  and  $\text{AIN}(-)$  pins for a minimum setup time ( $t_{\text{SETUP}}$ ) of 100 ns before the rising edge of  $\overline{\text{CS}}$ . This second write to the control register sets the  $\overline{\text{CONVST}}$  bit to 1 and at the end of this write operation the  $\text{BUSY}$  signal is triggered high (note that a  $\overline{\text{CONVST}}$  pulse can be applied instead of this second write to the control register). The  $\text{BUSY}$  signal is low after a time  $t_{\text{CAL2}}$  when the system offset calibration section is complete. The full system calibration is now complete.

The timing for a system (gain + offset) calibration is very similar to that of Figure 33, the only difference being that the time  $t_{\text{CAL1}}$  is replaced by a shorter time of the order of  $t_{\text{CAL2}}$  as the internal DAC is not calibrated. The  $\text{BUSY}$  signal signifies when the gain calibration is finished and when the part is ready for the offset calibration.

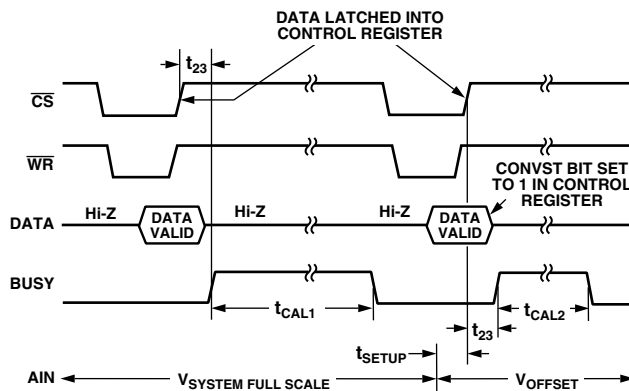

Figure 33. Timing Diagram for Full System Calibration

The timing diagram for a system offset or system gain calibration is shown in Figure 34. Here again a write to the control register initiates the calibration sequence. At the end of the control register write operation the  $\text{BUSY}$  line goes high and it stays high until the calibration sequence is finished. The analog input should be set at the correct level for a minimum setup time ( $t_{\text{SETUP}}$ ) of 100 ns before the rising edge of  $\overline{\text{CS}}$  and stay at the correct level until the  $\text{BUSY}$  signal goes low.

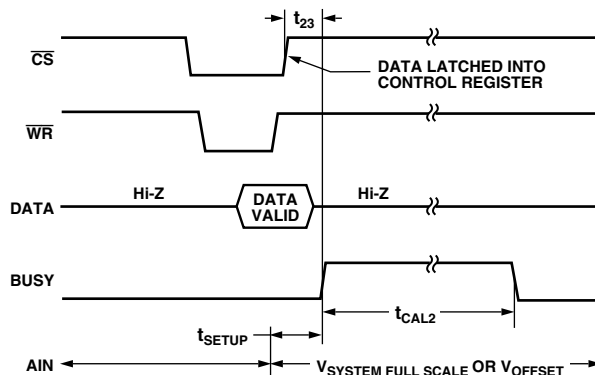

Figure 34. Timing Diagram for System Gain or System Offset Calibration

## PARALLEL INTERFACE

### Reading

The timing diagram for a read cycle is shown in Figure 35. The CONVST and BUSY signals are not shown here as the read cycle may occur while a conversion is in progress or after the conversion is complete.

The HBEN signal is low for the first read and high for the second read. This ensures that it is the lower 12 bits of the 16-bit word are output in the first read and the 8 MSBs of the 16-bit word are output in the second read. If required, the HBEN signal may be high for the first read and low for the second read to ensure that the high byte is output in the first read and the lower byte in the second read. The  $\overline{CS}$  and  $\overline{RD}$  signals are gated together internally and level triggered active low. Both  $\overline{CS}$  and  $\overline{RD}$  may be tied together as the timing specification for  $t_5$  and  $t_6$  are both 0 ns min. The data is output a time  $t_8$  after both  $\overline{CS}$  and  $\overline{RD}$  go low. The  $\overline{RD}$  rising edge should be used to latch the data by the user and after a time  $t_9$  the data lines will go into their high impedance state.

In Figure 35, the first read outputs the 12 LSBs of the 16-bit word on pins DB0 to DB11 (DB0 being the LSB of the 12-bit read). The second read outputs the 8 MSBs of the 16-bit word on pins DB0 to DB7 (DB0 being the LSB of the 8-bit read). If the system has a 12-bit or a 16-bit data bus, only one read operation is necessary to obtain the 12-bit conversion result (12 bits are output in the first read). A second read operation is not required.

If the system has an 8-bit data bus then two reads are needed. Pins DB0 to DB7 should be connected the 8-bit data bus. Pins DB8 to DB11 should be tied to DGND or  $DV_{DD}$  via 10 k $\Omega$  resistors. With this arrangement, HBEN is pulled low for the first read and the 8 LSBs of the 16-bit word are output on pins DB0 to DB7 (data on pins DB8 to DB11 will be ignored). HBEN is pulled high for the second read and now the 8 MSBs of the 16-bit word are output on pins DB0 to DB7.

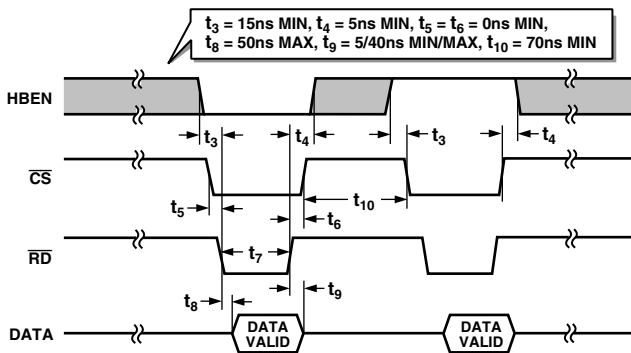

Figure 35. Read Cycle Timing Diagram Using  $\overline{CS}$  and  $\overline{RD}$

In the case where the AD7854/AD7854L is operated as a read-only ADC, the  $\overline{WR}$  pin can be tied permanently high. The read operation need only consist of one read if the system has a 12-bit or a 16-bit data bus.

When both the  $\overline{CS}$  and  $\overline{RD}$  signals are tied permanently low a different timing arrangement results, as shown in Figure 36. Here the data is output a time  $t_{20}$  before the falling edge of the BUSY signal. This allows the falling edge of BUSY to be used for latching the data. Again if HBEN is low during the conversion the 12 LSBs of the 16-bit word will be output on pins DB0

to DB11. Bringing HBEN high causes the 8 MSBs of the 16-bit word to be output on pins DB0 to DB7. Note that with this arrangement the data lines are always active.

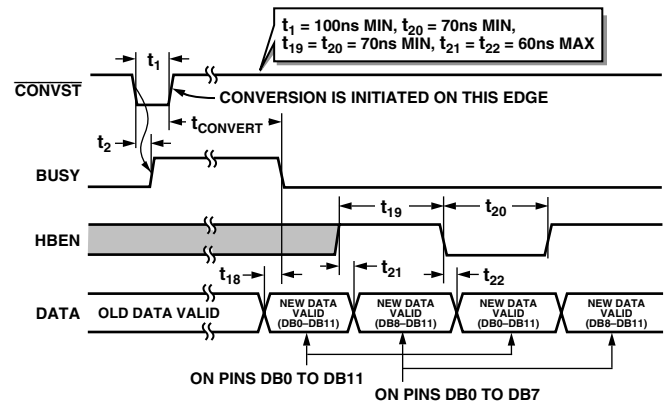

Figure 36. Read Cycle Timing Diagram with  $\overline{CS}$  and  $\overline{RD}$  Tied Low

### Writing

The timing diagram for a write cycle is shown in Figure 37. The CONVST and BUSY signals are not shown here as the write cycle may occur while a conversion is in progress or after the conversion is complete.

To write a 16-bit word to the AD7854/AD7854L, two 8-bit writes are required. The HBEN signal must be low for the first write and high for the second write. This ensures that it is the lower 8 bits of the 16-bit word are latched in the first write and the 8 MSBs of the 16-bit word are latched in the second write. For both write operations the 8 bits of data should be present on pins DB0 to DB7 (DB0 being the LSB of the 8-bit write). Any data on pins DB8 to DB11 is ignored when writing to the device. The  $\overline{CS}$  and  $\overline{WR}$  signals are gated together internally. Both  $\overline{CS}$  and  $\overline{WR}$  may be tied together as the timing specification for  $t_{13}$  and  $t_{14}$  are both 0 ns min. The data is latched on the rising edge of  $\overline{WR}$ . The data needs to be set up a time  $t_{16}$  before the  $\overline{WR}$  rising edge and held for a time  $t_{17}$  after the  $\overline{WR}$  rising edge.

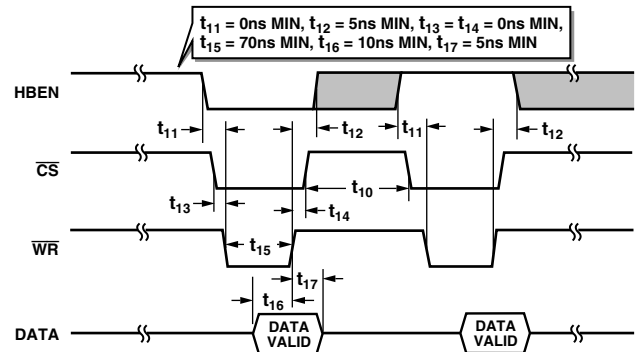

Figure 37. Write Cycle Timing Diagram

### Resetting the Parallel Interface

If random data has been inadvertently written to the test register, it is necessary to write the 16-bit word 0100 0000 0000 0010 (in two 8-bit bytes) to restore the test register to its default value.

# AD7854/AD7854L

## MICROPROCESSOR INTERFACING

The parallel port on the AD7854/AD7854L allows the device to be interfaced to microprocessors or DSP processors as a memory mapped or I/O mapped device. The  $\overline{CS}$  and  $\overline{RD}$  inputs are common to all memory peripheral interfacing. Typical interfaces to different processors are shown in Figures 38 to 41.

In all the interfaces shown, an external timer controls the  $\overline{CONVST}$  input of the AD7854/AD7854L and the  $\overline{BUSY}$  output interrupts the host DSP. Also, the  $\overline{HBEN}$  pin is connected to address line A0 (XA0 in the case of the TMS320C30). This maps the AD7854/AD7854L to two locations in the processor memory space,  $ADCaddr$  and  $ADCaddr+1$ . Thus when writing to the ADC, first the 8 LSBs of the 16-bit are written to address location  $ADCaddr$  and then the 8 MSBs to location  $ADCaddr+1$ . All the interfaces use a 12-bit data bus, so only one read is needed from location  $ADCaddr$  to access the ADC output data register or the status register. To read from the other registers, the 8 MSBs must be read from location  $ADCaddr+1$ . Interfacing to 8-bit bus systems is similar, except that two reads are required to obtain data from all the registers.

### AD7854/AD7854L to ADSP-21xx

Figure 38 shows the AD7854/AD7854L interfaced to the ADSP-21xx series of DSPs as a memory mapped device. A single wait state may be necessary to interface the AD7854/AD7854L to the ADSP-21xx depending on the clock speed of the DSP. This wait state can be programmed via the data memory waitstate control register of the ADSP-21xx (please see *ADSP-2100 Family Users Manual* for details). The following instruction reads data from the AD7854/AD7854L:

$AX0 = DM(ADCaddr)$

Data can be written to the AD7854/AD7854L using the instructions:

$DM(ADCaddr) = AY0$

$DM(ADCaddr+1) = AY1$

where  $ADCaddr$  is the address of the AD7854/AD7854L in ADSP-21xx data memory,  $AX0$  contains the data read from the ADC, and  $AY0$  contains the 8 LSBs and  $AY1$  the 8 MSBs of data written to the AD7854/AD7854L.

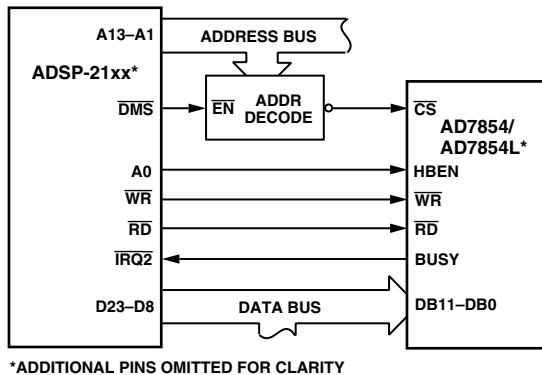

Figure 38. AD7854/AD7854L to ADSP-21xx Parallel Interface

### AD7854/AD7854L to TMS32020, TMS320C25 and TMS320C5x

A parallel interface between the AD7854/AD7854L and the TMS32020, TMS320C25 and TMS320C5x family of DSPs are shown in Figure 39. The memory mapped addresses chosen for the AD7854/AD7854L should be chosen to fall in the I/O memory space of the DSPs.

The parallel interface on the AD7854/AD7854L is fast enough to interface to the TMS32020 with no extra wait states. In the TMS320C25 interface, data accesses may be slowed sufficiently when reading from and writing to the part to require the insertion of one wait state. In such a case, this wait state can be generated using the single OR gate to combine the  $\overline{CS}$  and  $\overline{MSC}$  signals to drive the  $\overline{READY}$  line of the TMS320C25, as shown in Figure 39. Extra wait states are necessary when using the TMS320C5x at their fastest clock speeds. Wait states can be programmed via the IOWSR and CWSR registers (please see TMS320C5x User Guide for details).

Data is read from the ADC using the following instruction:

$IN D, ADCaddr$

where  $D$  is the memory location where the data is to be stored and  $ADCaddr$  is the I/O address of the AD7854/AD7854L.

Data is written to the ADC using the following two instructions:

$OUT D8LSB, ADCaddr$

$OUT D8MSB, ADCaddr+1$

where  $D8LSB$  is the memory location where the 8 LSBs of data are stored,  $D8MSB$  is the location where the 8 MSBs of data are stored and  $ADCaddr$  and  $ADCaddr+1$  are the I/O memory spaces that the AD7854/AD7854L is mapped into.

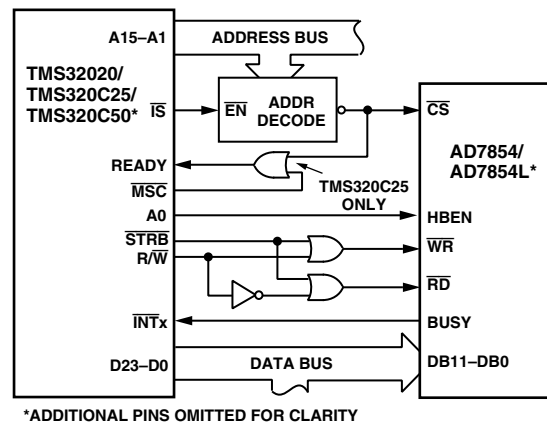

Figure 39. AD7854/AD7854L to TMS32020/C25/C5x Parallel Interface



## AD7854/AD7854L to TMS320C30

Figure 40 shows a parallel interface between the AD7854/AD7854L and the TMS320C3x family of DSPs. The AD7854/AD7854L is interfaced to the Expansion Bus of the TMS320C3x. Two wait states are required in this interface. These can be programmed using the WTCNT bits of the Expansion Bus Control register (see *TMS320C3x Users Guide* for details). Data from the AD7854/AD7854L can be read using the following instruction:

```
LDI *ARn,Rx
```

Data can be loaded into the AD7854/AD7854L using the instructions:

```
STI Ry,*ARn++
```

```
STI Rz,*ARn--
```

where  $ARn$  is an auxiliary register containing the lower 16 bits of the address of the AD7854/AD7854L in the TMS320C3x memory space,  $Rx$  is the register into which the ADC data is loaded during a load operation,  $Ry$  contains the 8 LSBs of data and  $Rz$  contains the 8 MSBs of data to be written to the AD7854/AD7854L.

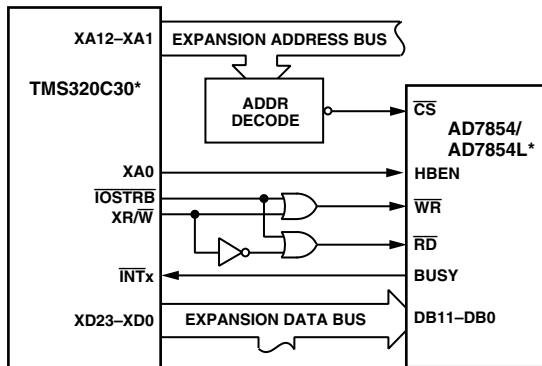

\*ADDITIONAL PINS OMITTED FOR CLARITY

Figure 40. AD7854/AD7854L to TMS320C30 Parallel Interface

## AD7854/AD7854L to DSP5600x

Figure 41 shows a parallel interface between the AD7854/AD7854L and the DSP5600x series of DSPs. The AD7854/AD7854L should be mapped into the top 64 locations of Y data memory. If extra wait states are needed in this interface, they can be programmed using the Port A bus control register (please see *DSP5600x User's Manual* for details). Data can be read from the DSP5600x using the following instruction:

```
MOVE Y:ADCaddr, X0
```

Data can be written to the AD7854/AD7854L using the following two instructions:

```
MOVE X0, Y:ADCaddr
```

```
MOVE X1, Y:ADCaddr+1
```

Where  $ADCaddr$  is the address in the DSP5600x address space to which the AD7854/AD7854L has been mapped.

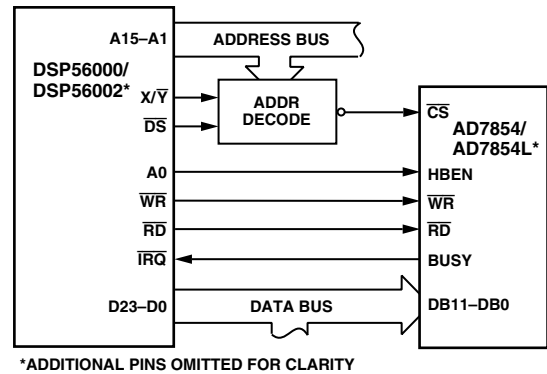

\*ADDITIONAL PINS OMITTED FOR CLARITY

Figure 41. AD7854/AD7854L to DSP5600x Parallel Interface

# AD7854/AD7854L

## APPLICATION HINTS

### Grounding and Layout

The analog and digital supplies of the AD7854/AD7854L are independent and separately pinned out to minimize coupling between the analog and digital sections of the device. The part has very good immunity to noise on the power supplies as can be seen by the PSRR versus frequency graph. However, care should still be taken with regard to grounding and layout.

The printed circuit board on which the AD7854/AD7854L is mounted should be designed such that the analog and digital sections are separated and confined to certain areas of the board. This facilitates the use of ground planes that can be easily separated. A minimum etch technique is generally best for ground planes as it gives the best shielding. Digital and analog ground planes should only be joined in one place. If the AD7854/AD7854L is the only device requiring an AGND to DGND connection, then the ground planes should be connected at the AGND and DGND pins of the AD7854/AD7854L. If the AD7854/AD7854L is in a system where multiple devices require AGND to DGND connections, the connection should still be made at one point only, a star ground point which should be established as close as possible to the AD7854/AD7854L.

Avoid running digital lines under the device as these couple noise onto the die. The analog ground plane should be allowed to run under the AD7854/AD7854L to avoid noise coupling. The power supply lines to the AD7854/AD7854L should use as large a trace as possible to provide low impedance paths and reduce the effects of glitches on the power supply line. Fast switching signals like clocks and the data inputs should be shielded with digital ground to avoid radiating noise to other sections of the board and clock signals should never be run near the analog inputs. Avoid crossover of digital and analog signals. Traces on opposite sides of the board should run at right angles to each other. This reduces the effects of feedthrough through the board. A microstrip technique is by far the best but is not always possible with a double-sided board. In this technique, the component side of the board is dedicated to ground planes while signals are placed on the solder side.

Good decoupling is also important. All analog supplies should be decoupled with a 10  $\mu\text{F}$  tantalum capacitor in parallel with 0.1  $\mu\text{F}$  disc ceramic capacitor to AGND. All digital supplies should have a 0.1  $\mu\text{F}$  disc ceramic capacitor to DGND. To achieve the best performance from these decoupling components, they must be placed as close as possible to the device, ideally right up against the device. In systems where a common supply voltage is used to drive both the  $\text{AV}_{\text{DD}}$  and  $\text{DV}_{\text{DD}}$  of the AD7854/AD7854L, it is recommended that the system's  $\text{AV}_{\text{DD}}$  supply is used. In this case an optional 10  $\Omega$  resistor between the  $\text{AV}_{\text{DD}}$  pin and  $\text{DV}_{\text{DD}}$  pin can help to filter noise from digital circuitry. This supply should have the recommended analog supply decoupling capacitors between the  $\text{AV}_{\text{DD}}$  pin of the AD7854/AD7854L and AGND and the recommended digital supply decoupling capacitor between the  $\text{DV}_{\text{DD}}$  pin of the AD7854/AD7854L and DGND.

### Evaluating the AD7854/AD7854L Performance

The recommended layout for the AD7854/AD7854L is outlined in the evaluation board for the AD7854/AD7854L. The evaluation board package includes a fully assembled and tested evaluation board, documentation, and software for controlling the board from the PC via the EVAL-CONTROL BOARD. The EVAL-CONTROL BOARD can be used in conjunction with the AD7854/AD7854L Evaluation board, as well as many other Analog Devices evaluation boards ending in the CB designator, to demonstrate/evaluate the ac and dc performance of the AD7854/AD7854L.

The software allows the user to perform ac (fast Fourier transform) and dc (histogram of codes) tests on the AD7854/AD7854L. It also gives full access to all the AD7854/AD7854L on-chip registers allowing for various calibration and power-down options to be programmed.

### AD785x Family

All parts are 12 bits, 200 kSPS, 3.0 V to 5.5 V.

### AD7853 – Single Channel Serial

### AD7854 – Single Channel Parallel

### AD7858 – Eight Channel Serial

### AD7859 – Eight Channel Parallel

## PAGE INDEX

Topic	Page	Topic	Page
FEATURES	1	CALIBRATION SECTION	20
GENERAL DESCRIPTION	1	Calibration Overview	20
PRODUCT HIGHLIGHTS	1	Automatic Calibration on Power-On	20
SPECIFICATIONS	2	Self-Calibration Description	20
TIMING SPECIFICATIONS	4	Self-Calibration Timing	21
ABSOLUTE MAXIMUM RATINGS	5	System Calibration Description	21
ORDERING GUIDE	5	System Gain and Offset Interaction	22
PINOUTS	5	System Calibration Timing	22
TERMINOLOGY	6	PARALLEL INTERFACE	23
PIN FUNCTION DESCRIPTION	7	Reading	23
AD7854/AD7854L ON-CHIP REGISTERS	8	Writing	23
Addressing the On-Chip Registers	8	Resetting the Parallel Interface	23
Writing/Reading	8	MICROPROCESSOR INTERFACING	24
CONTROL REGISTER	9	AD7854/AD7854L to ADSP-21xx	24
STATUS REGISTER	10	AD7854/AD7854L to TMS32020, TMS320C25 and TMS320C5x	24
CALIBRATION REGISTERS	11	AD7854/AD7854L to TMS320C30	25
Addressing the Calibration Registers	11	AD7854/AD7854L to DSP5600x	25
Writing to/Reading from the Calibration Registers	11	APPLICATIONS HINTS	26
Adjusting the Offset Calibration Register	12	Grounding and Layout	26
Adjusting the Gain Calibration Register	12	Evaluating the AD7854/AD7854L Performance	26
CIRCUIT INFORMATION	13	INDEX	27
CONVERTER DETAILS	13	OUTLINE DIMENSIONS	28
TYPICAL CONNECTION DIAGRAM	13		
ANALOG INPUT	14	<b>TABLE INDEX</b>	
Acquisition Time	14	<b>#</b> <b>Title</b>	<b>Page</b>
DC/AC Applications	14	I   Write Register Addressing	8
Input Ranges	15	II  Read Register Addressing	8
Transfer Functions	15	III Calibration Selection	9
REFERENCE SECTION	16	IV  Calibrating Register Addressing	11
AD7854/AD7854L PERFORMANCE CURVES	16	V   Analog Input Connections	15
POWER-DOWN OPTIONS	17	VI  Power Management Options	17
POWER-UP TIMES	17	VII Power Consumption vs. Throughput	18
Using an External Reference	17	VIII Calibration Times (AD7854 with 4 MHz CLKIN)	20
Using the Internal (On-Chip) Reference	18		
POWER VS. THROUGHPUT RATE	18		

**OUTLINE DIMENSIONS**

Dimensions shown in inches and (mm).

**28-Lead Cerdip  
(Q-28)**

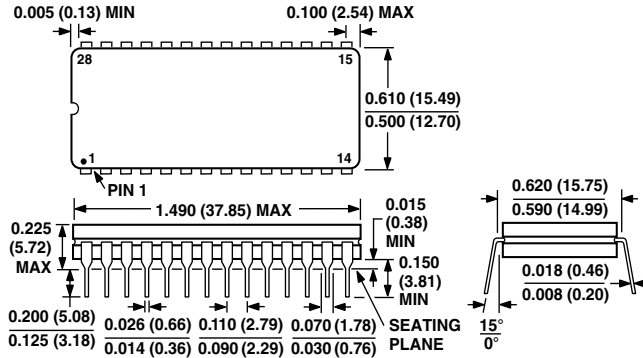

**28-Lead Small Outline Package  
(R-28)**

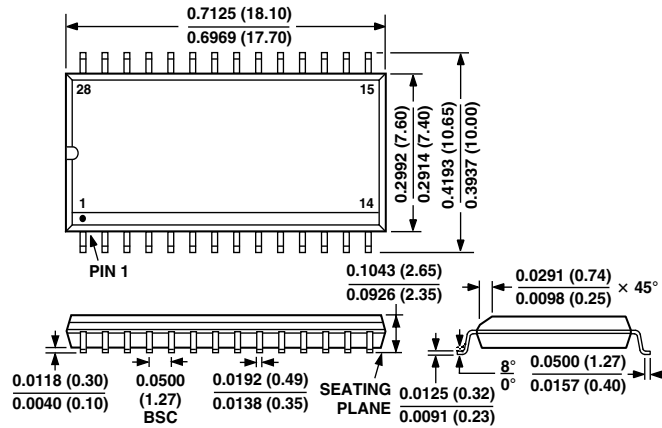

**28-Lead Shrink Small Outline Package  
(RS-28)**

