

## DESCRIPTION

Demonstration circuit 1495A showcases the LT2940 Power Monitor, configured to measure up to 30W over a range of 8V to 40V and 0A to 3A. LEDs indicate when the load power exceeds 12.5W. Power is indicated at PMON with a scaling factor of 10W/V; IMON indicates current at 1A/V.

All scaling factors and the voltage and current measurement ranges may be reconfigured by changing a few resistors. The LT2940's compar-

tor can monitor either the power output, PMON, or the current output, IMON.

**Design files for this circuit board are available. Call the LTC factory.**

LT, LTC, LTM, LT, Burst Mode, OPTI-LOOP, Over-The-Top and PolyPhase are registered trademarks of Linear Technology Corporation. Adaptive Power, C-Load, DirectSense, Easy Drive, FilterCAD, Hot Swap, LinearView,  $\mu$ Module, Micropower SwitcherCAD, Multimode Dimming, No Latency  $\Delta\Sigma$ , No Latency Delta-Sigma, No  $R_{SENSE}$ , Operational Filter, PanelProtect, PowerPath, PowerSOT, SmartStart, SoftSpan, Stage Shedding, SwitcherCAD, ThinSOT, UltraFast and VLDO are trademarks of Linear Technology Corporation. Other product names may be trademarks of the companies that manufacture the products.

## PERFORMANCE SUMMARY Specifications are at TA = 25°C

SYMBOL	PARAMETER	CONDITIONS	MIN	TYP	MAX	UNITS
$V_{IN}$	Input Supply Range		8		40	V
$V_{CC}$	$V_{CC}$ Supply Range	(When Separately Powered)	12		80	V
PMON	Load Power for Full Scale Output	PMON = 3V	27	30	33	W
IMON	Load Current for Full Scale Output	IMON = 3V	2.85	3	3.15	A
P <sub>TRIP</sub>	Overpower Threshold	Red LED Turns On	11	12.5	14	W

## OVERVIEW

The LT2940 is a four-quadrant multiplier designed to measure current and voltage, multiply them, and produce an output proportional to power. A second output is proportional to the measured current. All inputs and outputs are bipolar; the LT2940 measures positive or negative power, voltage and current. The power and current outputs operate in current mode, with a full scale of  $\pm 200\mu\text{A}$ . To facilitate use in a practical application, the current sense pins (I+ and I-) are designed to operate over a 4V to 80V common mode range, independent of the supply pin,  $V_{CC}$ . This permits the LT2940 to measure, for example, a 48V supply while operating on a 12V supply. The LT2940 includes an auxiliary comparator with a fixed 1.25V reference and complementary outputs.

A distinction must be drawn between the features and performance of the LT2940, and the features and performance of DC-1495A. The LT2940 has the following important features:

- Four quadrant power measurement with bidirectional power and current outputs
- $V_{CC}$ -independent, high-side current sense input
- 4V to 80V current sense input operating range
- 6V to 80V  $V_{CC}$  operating range
- 100V absolute maximum rating

# DC-1495A

- Auxiliary comparator with complementary outputs

As configured, DC-1495A features:

- Single quadrant power and current measurement with unidirectional outputs
- 8V to 40V, 0A to 3A measurement range
- 30W full scale power monitor output, 10W/V
- 3A full scale current monitor output, 1A/V
- 75V maximum input, limited by clamp
- $V_{CC}$  connected to INPUT turret
- LEDs indicate load power above (red) or below (green) 12.5W

DC-1495A includes provision for optional components, allowing the board to be reconfigured for different scaling and a variety of applications.

## Components

Components are divided into four basic groups:

R12A, R12B, R12C, C1, D1, D2: these components are associated with  $V_{CC}$  (D1 supplies constant current to the LEDs). A zero ohm jumper installed in any one of the R12 positions selects the source of power for  $V_{CC}$ : input, output, or external supply connected to the  $V_{CC}$  turret. Use a resistor if filtering is desired. As built R12B is stuffed with  $10\Omega$  and  $V_{CC}$  is bypassed with 100nF, serving both as a  $V_{CC}$  filter and also as a snubber for the input.

An SMAT70A clamp diode, D2, is connected directly across the input to ground. It has a maximum dc standoff rating of 75V. Do not exceed 75Vdc or D2 will be permanently damaged. The LT2940 can tolerate up to 100V input absolute maximum on the  $V_{CC}$ , I+, I- and LATCH pins. Nevertheless, when connecting to supplies greater than 50V it is possible to exceed 100V owing to ringing. D2 is included to prevent destruction of the LT2940 while performing bench tests.

R9A, C2, R9B: configuration resistors and noise filter for the LATCH pin. As stuffed the comparator operates in “flow-through” mode; install  $47k\Omega$  at

R9B or tie the LATCH turret high ( $>2.5V$ ) for latching behavior. Grounding the LATCH turret clears the comparator after latching.

RJ-2, R2A, R1A, R1C, R2B, R1B: divider components for voltage sense pins  $V+$  and  $V-$ . As stuffed, R2A and R1A form a 5:1 divider that monitors the output voltage, with a 40V full scale value. By re-arranging the components it is possible to achieve a variety of configurations for single-ended and differential voltage measurements.

C3, R3, RJ-4, RJ-5, R4B, R4A, C4, R5B, R5A, C5: configuration and scaling resistors and integration or filter capacitors for PMON, IMON and the comparator input, CMP+. DC-1495A is stuffed with  $15k\Omega$  load resistors for PMON and IMON (R4A and R5A), and RJ-4 connects PMON to CMP+.

Positions are provided for 3 sense resistors, allowing for high current operation or for combining two or three resistors in parallel to achieve a specific value. Sufficient copper is present on the circuit board to handle more than 10A; beyond this point DC-1495A can be connected to an off-board sense resistor or shunt using the INPUT and OUTPUT terminals. In this case remove RS1, RS2, and RS3. The I+ and I- terminals allow precise Kelvin examination of the current sense signal, as seen by the LT2940.

## Multiplier Operation

The LT2940 has two differential inputs which we will call  $V_V$  and  $V_I$ .  $V_V$  is the voltage across the  $V+$  and  $V-$  voltage input pins, and  $V_I$  is the voltage across the I+ and I- current sense input pins. The voltages at these inputs are multiplied together by a four-quadrant Gilbert cell, producing a current at the PMON output proportional to the product of  $V_V$  and  $V_I$ . Specifically,

$$\text{PMON Output Current} = V_V \times V_I \times 500\mu A/V^2$$

Where  $500\mu A/V^2$  is the gain or transfer function of the multiplier, and a  $V_V \times V_I$  product of  $0.4V^2$  drives the PMON output to 200 $\mu A$  full scale.

Although the multiplier core can handle a maximum  $V_V \times V_I$  product of just  $\pm 0.4V^2$ , the voltage

and current inputs can handle  $\pm 8V$  and  $\pm 200mV$  without clipping. Thus it is possible to produce a full scale  $V_V \times V_I$  product of  $0.4V^2$  with inputs of  $4V \times 100mV$ ,  $8V \times 50mV$ , or  $2V \times 200mV$ , to name just a few possible combinations. In effect, the LT2940 PMON output can be made to operate at full scale over an input voltage or current range of 4:1. A load resistor connected from PMON to ground (R4A) establishes the final scaling factor and full scale output voltage.

### Current Monitor

The current sense input,  $V_I$ , is monitored by a gm stage producing  $200\mu A$  full scale at the IMON output for a  $200mV$  input, corresponding to a gm of  $1mA/V$ .

### Scaling

DC-1495A is easily modified or re-scaled for other voltage, current and power levels, by changing a few resistors. The primary objective is to produce as much PMON output signal as possible at maximum input power, without overdriving the current and voltage inputs. The problem is where do you start?

Where scaling is concerned, most applications will fall into one of two classes: constant resistance loads and constant power loads. If the load is constant resistance, maximum power, maximum voltage and maximum current all coincide. The voltage input  $V_V$  can be scaled for  $4V$  and the current input  $V_I$  scaled for  $100mV$  at this point. For example, a  $20\Omega$  load with a maximum input voltage of  $20V$  is scaled with a voltage divider of 5:1 producing  $4V$ , and a sense resistor of  $100m\Omega$  producing  $100mV$  at  $20V/20\Omega=1A$ .

If the load is constant power, the voltage and current inputs can be scaled to the mid-point of the input operating voltage range. For example, maximum power is  $100W$  and the input voltage range is  $40V$  to  $60V$ , scale the voltage input to  $4V$  with a  $50V$  input (12.5:1) and the current input to  $100mV$  ( $2A$  dropped across  $50m\Omega$  sense resistor). When scaled in this fashion, there is plenty of operating range in the voltage and current inputs to handle the  $40V$  and  $60V$  corners.

In any application, the output voltage is set with a load resistor. For example, if an input of  $2W$  drives the multiplier to  $200\mu A$  full scale, a PMON load resistor of  $10k\Omega$  produces  $2V$ , a convenient scaling factor of  $1W/V$ . The IMON output is similarly treated. The accuracy of the IMON output is not affected by over-ranging the multiplier.

### Telecom Example

For a  $200W$  telecom application with an operating range of  $20V$  to  $80V$ , use the following component values:

Voltage divider: 10:1;  $R2A=102k\Omega$ ,  $R2B=11.3k\Omega$ , 1%;  $R1B=0\Omega$

Current sense resistor:  $RS1=20m\Omega$ , 1%,  $1W$

PMON output resistor:  $R4A=10.0k\Omega$ , 1%

PMON scaling:  $100W/V$ ,  $2V=200W$  full scale

IMON output resistor:  $R5A=49.9k\Omega$ , 1%

IMON scaling:  $1A/V$ ,  $10V=10A$  full scale

For a summary of input and output ranges and limits, see Table 1 in the LT2940 data sheet.

## QUICK START PROCEDURE

Operation of DC-1495A is straightforward: connect an input supply of  $8V$  to  $40V$ , connect a voltmeter to the PMON turret and add a load to the output. The voltmeter will indicate load power with a scaling factor of  $10W/V$ . IMON is scaled at  $1A/V$ .

For example, a  $10\Omega$  load and  $10V$  supply will generate a PMON output voltage of  $1V$ , indicating a power of  $10W$ . Increasing the input voltage to  $11.2V$  will increase the power to the  $12.5W$  trip threshold and the red LED will turn on.

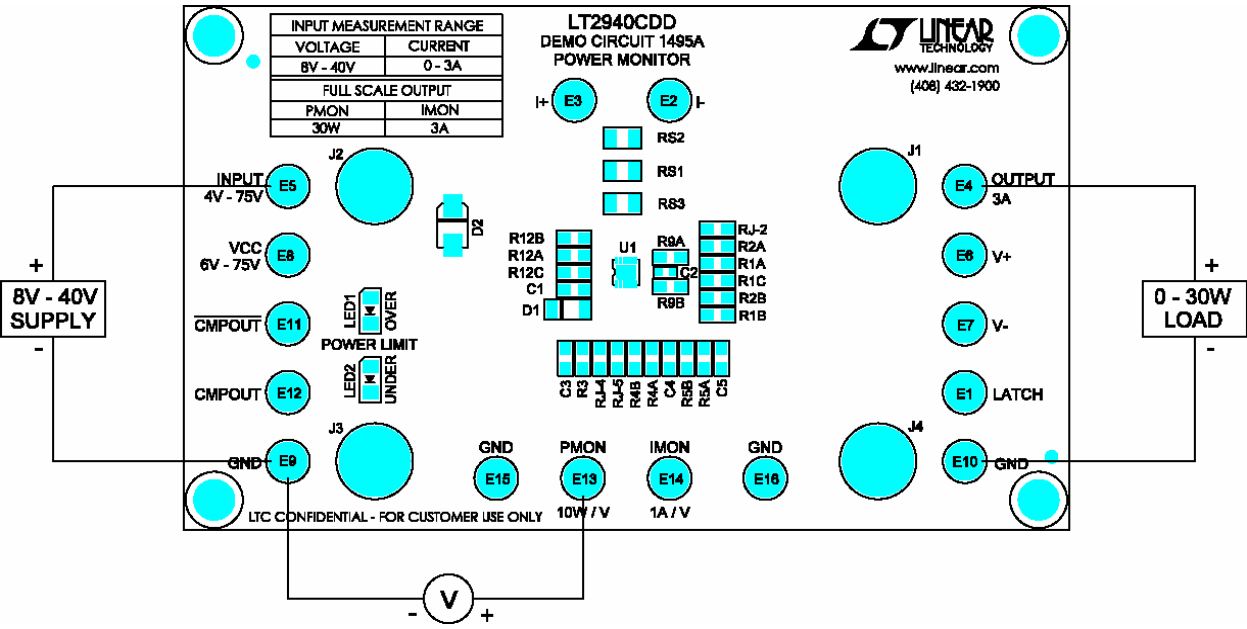

Figure 1. Proper Measurement Equipment Setup



# DC-1495A

Item	Qty	Ref -Des	Desc	Manufacturer's Part Number
1	1	C1	CAP, 0805 100nF 10% 100V X7R	TDK C2012X7R2A104K
2	1	C2	CAP, 0603 10nF 10% 50V X7R	AVX 06035C103KAT2A
3	3	C3,C4,C5	CAP, 0805 OPTION	OPTION
4	1	D1	DIODE, FIELD EFFECT CURRENT REGULATOR SOD-80	CENTRAL SEMI CCLM2700
5	1	D2	DIODE, TRANSIENT VOLTAGE SUPPRESSOR SMA	DIODES INC. SMAT70A
6	16	E1-E16	TURRET	MILL-MAX 2501-2-00- 80-00-00-07-0
7	4	J1,J2,J3,J4	JACK, BANANA	KEYSTONE 575-4
8	1	LED1	LED, RED	PANASONIC LN1251- C-TR
9	1	LED2	LED, GREEN	PANASONIC LN1351- C-TR
10	5	R1B,RJ-2,RJ- 4,R4B,R5B	RES, 0805 0 OHM JUMPER	VISHAY CRCW08050000Z0EA
11	0	R1C,R2B,R3,RJ- 5,R9B,R12C, R12A	RES, 0805 OPTION	OPTION
12	3	RS1,RS2,RS3	RES, 1206 200m OHMS 1% 100ppm/Degrees C	TEPRO TT6-R200-F- 100L
13	1	R1A	RES, 0805 25.5K OHMS 1% 1/8W	NIC NRC10F2552TRF
14	1	R2A	RES, 0805 102K OHMS 1% 1/8W	NIC NRC10F1023TRF
15	2	R4A,R5A	RES, 0805 15K OHMS 1% 1/8W	NIC NRC10F1502TRF
16	1	R9A	RES, 0805 22K OHMS 5% 1/8W	VISHAY CRCW080522K0JNE A
17	1	R12B	RES, 0805 10 OHMS 5% 1/8W	NIC NRC10J100TRF
18	1	U1	IC, POWER MONITOR	LINEAR TECH LT2940CDD
19	4		STANDOFF, SNAP ON	KEYSTONE_8831