

WIRE COMBINATIONS FOR NYLON-INSUALTED CLOSED END CONNECTORS

MOLEX P/N: 191600002 (NC-1610), 191600128 (NC-1610 BULK)
191600083 (NC-1610T), 191600156 (NC-1610BT)

UL LISTED & CSA CERTIFIED WIRE COMBINATIONS
SOLID OR STRANDED, COPPER WIRE ONLY

12 AWG	14 AWG	16 AWG	18 AWG
1		1	
1			1
1			2
	1	1	
	1	2	
	1		1
	1		2
	1		3
	1	1	1
		1	1
		1	2
		1	3
		1	4
		2	1
		2	2
		2	3

12 AWG	14 AWG	16 AWG	18 AWG
		2	
		3	1
		3	
		5	3
			1
			4
	2		
	1	2	1
	1	3	
1	1		
		5	
		2	
	1		

ADDITIONAL UL LISTED WIRE COMBINATIONS

- (1) 18 AWG SOLID WITH (2) 18 AWG STRANDED
- (2) 18 AWG SOLID TWISTED OR UNTWISTED
- (2) 18 AWG STRANDED TWISTED OR UNTWISTED
- (1) 12 AWG SOLID WITH (1) 14 AWG STRANDED
- (1) 12 AWG SOLID WITH (1) 12 AWG STRANDED
- (1) 20 AWG STRANDED WITH (1) 18 AWG STRANDED
- (1) 20 AWG STRANDED WITH (2) 18 AWG STRANDED
- (2) 20 AWG STRANDED WITH (1) 18 AWG STRANDED
- (3) 20 AWG STRANDED
- (3) 20 AWG STRANDED WITH (1) 18 AWG STRANDED
- (4) 20 AWG STRANDED
- (1) 20 AWG STRANDED WITH (2) 14 AWG STRANDED
- (2) 12 AWG STRANDED
- (3) 14 AWG STRANDED
- (3) 14 AWG SOLID

NOTE: THIS DOCUMENT USED TO MAKE STUFFER SHEET
PART NO: 194080109
DOC NO'S: E-19160-009 & PK-19408-109

WIRE PREPARATION:

- NOTE: PRE-TWISTING NOT REQD FOR OEM APPLICATIONS
SOLID: (OEM ONLY)
A. STRIP LEADS TO .38(9.5)
B. INSERT INTO CONNECTOR & CRIMP
STRANDED:
A. STRIP LEADS TO APROX. .75(19.1)
B. TWIST WIRE COMBINATION EVENLY & TIGHT.
C. TRIM STRIPPED PRE-TWISTED ZONE TO .38(9.5).
D. INSERT INTO CONNECTOR AND CRIMP.

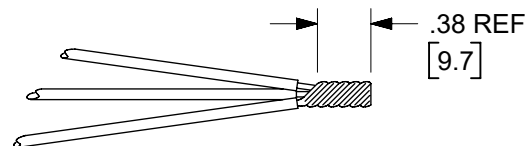

RATING 105°C 600 VOLT
(1000 VOLT IN SIGNS OR FIXTURES)
FILE: E32244



RATING 105°C 600 VOLT
(1000 VOLT IN SIGNS OR FIXTURES)
FILE: LR 18689
* 125°C FOR PRE-TWISTED WIRE ONLY

APPLICATION WITH HANDTOOL:

HOLD TOOL WITH LOCATOR PLATE FACING UP.
INSERT CLOSED END CONNECTOR IN HOLE.
INSURE THAT SHOULDER OF CONNECTOR IS RESTING
ON LOCATOR PLATE.
CLOSE TOOL JAWS UNTIL CONNECTOR IS HELD SNUG IN PLACE.
LOAD CONNECTOR WITH DESIRED WIRE COMBINATION.
COMPLETE CRIMP BY CLOSING TOOL HANDLES UNTIL
THEY RELEASE.

CRIMP TOOLING AVAILABLE:

192880030 (ATP-301) AIR TAPE PRESS OR
638858400 MINI-MAC TAPE APPLICATOR WITH
192880236 (ATP-NC-1610) CRIMPING DIES OR
NCEC CRIMP DIE-MARKED, "SIZE 16-10"

640010600 (RHT-7000) HANDTOOL
640050600 (AT-7000) CRIMP HEAD OR 640053500 (AT-1610) CRIMP HEAD
FOR 192790001 (AT-200) AIR HAND TOOL

FUNCTIONAL SYMBOLS FA = 0 FE = 0 FD = 0	THIS DRAWING CONTAINS INFORMATION THAT IS PROPRIETARY TO MOLEX ELECTRONIC TECHNOLOGIES, LLC AND SHOULD NOT BE USED WITHOUT WRITTEN PERMISSION		CURRENT REV DESC: P/N TYPO/ ERROR: 191600128 WAS 191620128 & 191600156 WAS 191620156. CRIMP TOOLING PN'S UPDATED.		<p>CLOSED END CONNECTOR WIRE COMBINATNS NC-1610 PRODUCT SPECIFICATION</p>
	DIMENSION UNITS	SCALE	GENERAL TOLERANCES (UNLESS SPECIFIED)		
	INCH/MM	NTS	MM	INCH	
	DIVISIONAL SYMBOLS		4 PLACES ±	3 PLACES ±	
1 PLACE ±		0 PLACES ±	ANGULAR TOL ± °		EC NO: 704038 DRWN: DMYRICK 2022/04/08 CHKD: JMACNEIL 2022/05/04 APPR: JMACNEIL 2022/05/04
DRAFT WHERE APPLICABLE MUST REMAIN WITHIN DIMENSIONS		THIRD ANGLE PROJECTION	DRAWING	SERIES	INITIAL REVISION: DRWN: JHACKNEY 1999/11/01 APPR: JMACNEIL 2012/06/06
DOCUMENT STATUS		DOC TYPE	DOC PART	REVISION	DOCUMENT NUMBER
P1	RELEASE DATE	PSD	001	F	PS-19160-005
2022/05/04	14:37:29	GENERAL MARKET	SEE CHART	1 OF 1	

LOOSE PIECE		TAPE MOUNTED		"L" MAX.	"B" MIN (G1)	"D" MAX.	"E" MIN.	I.D. MIN.	O.D. MAX.	"A" DIM ±.02/0.5 (G1)
MATERIAL NO.	ENG. NO.	MATERIAL NO.	ENG. NO.							
191600012	NC-2214	191600070	NC-2214T	.62/15.7	.30/7.6	.19/4.8	.24/6.1	.09/2.3	.32/8.1	1.54/39.2
191600009	NC-2212	191600071	NC-2212T	.76/19.3	.30/7.6	.23/5.8	.27/6.9	.10/2.5	.36/9.1	1.63/41.4
191600002	NC-1610	191600083	NC-1610T	.90/22.8	.28/7.1	.28/7.1	.38/9.6	.15/3.8	.45/11.4	1.75/44.5
191600024	NC-8	191600028	NC-8T	1.10/27.9	.42/10.6	.36/9.1	.48/12.2	.21/5.3	.57/14.5	1.86/47.4

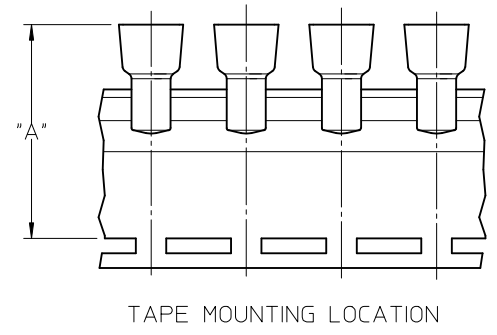
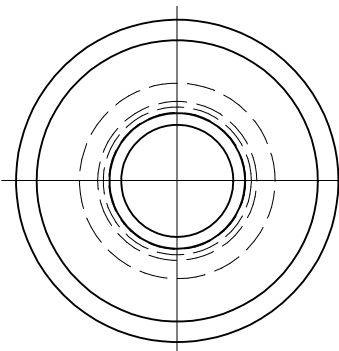
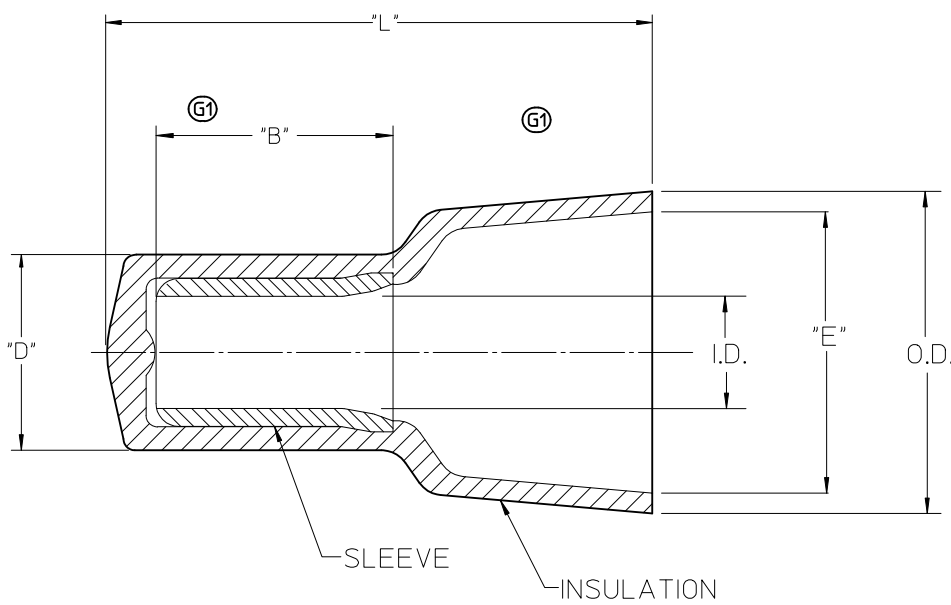

NOTES:

- MATERIAL: SLEEVE: TIN-PLATED COPPER
INSULATION: 6/6 NYLON,
NATURAL TRANSLUCENT
- PARTS ARE ROHS COMPLIANT.

SALES DRAWING

CORRECT TOLERANCES EC NO: WNA2010-0673 DRAWN BY: DRW/ETHRODAHL 2010/05/07 CHKD.R: DEROSS 04/02/23 APPR: JMACEIL 2010/06/23	QUALITY SYMBOLS	GENERAL TOLERANCES (UNLESS SPECIFIED)	DIMENSION STYLE	SCALE	DESIGN UNITS	THIRD ANGLE PROJECTION
	▽=0	mm INCH	IN/MM	5:1	INCH	
	▽=0	4 PLACES ± --- ± ---	DRAWN BY DATE			
		3 PLACES ± --- ± ---	H.BEITZE 04/02/23	TITLE		
	2 PLACES ± --- ± ---	CHECKED BY DATE				CLOSED END CONNECTORS NYLON INSULATED
	1 PLACE ± --- ± ---	R.DEROSS 04/02/23				
	ANGULAR ± ---°	APPROVED BY DATE				MOLEX INCORPORATED
		R.DEROSS 04/02/23				
		DRAFT WHERE APPLICABLE MUST REMAIN WITHIN DIMENSIONS	SEE CHART			DOCUMENT NO. SD-19160-001
			SIZE B			SHEET NO. 1 OF 1