

**SAW Filter 866.50MHz**  
**Part No: MP02248**

**Model No: TA0801A**  
**Rev No: 4**

**A. MAXIMUM RATING:**

Electrostatic Sensitive Device (ESD)

1. Input Power Level: 18dBm
2. DC voltage: 3V
3. Operating Temperature: -40°C to +85°C
4. Storage Temperature: -40°C to +85°C
5. Moisture Sensitive Level: Level 1(MSL1)

**B. ELECTRICAL CHARACTERISTICS:**

Item	Unit	Min.	Typ.	Max.
Center frequency Fc	MHz	-	866.5	-
Insertion loss at Fc Amax	dB	-	2.3	3.0
Ripple (863 ~ 870MHz)	dB	-	0.3	1.3
VSWR (863 ~ 870MHz)		-	1.2	2.0
Attenuation (Reference level from Amax)				
10 ~ 830MHz	dB	45	49	-
830 ~ 850MHz	dB	22	35	-
885 ~ 905MHz	dB	27	35	-
905 ~ 950MHz	dB	45	49	-
950 ~ 1500MHz	dB	40	47	
1500 ~ 3000MHz	dB	25	28	
Temperature coefficient of frequency TCf	-36ppm / °C			

**SAW Filter 866.50MHz**  
**Part No: MP02248**

**Model No: TA0801A**  
**Rev No: 4**

**C. FREQUENCY CHARACTERISTICS:**

1. Wide band Response: (span 100MHz)

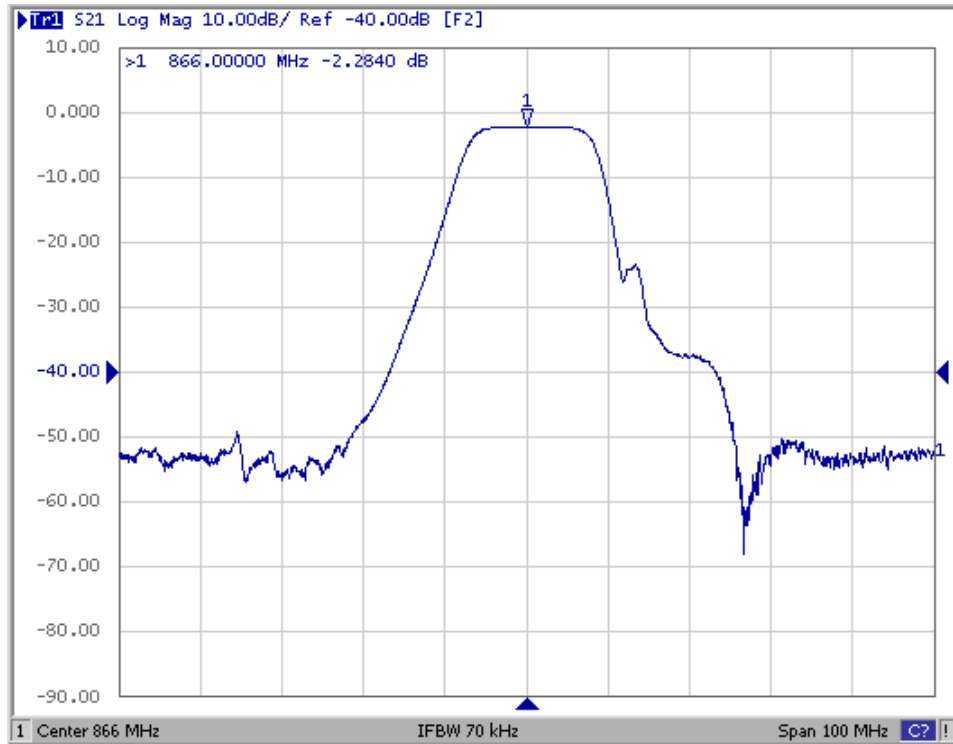

2. Wide band response: (300k ~ 3GHz)

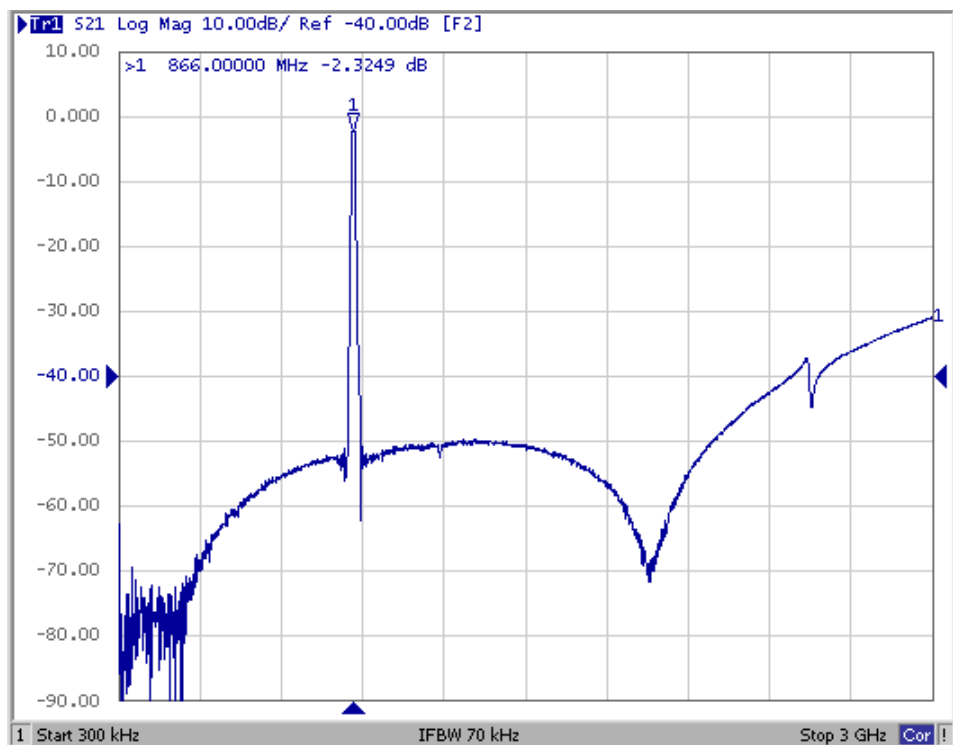

**SAW Filter 866.50MHz**  
**Part No: MP02248**

**Model No: TA0801A**  
**Rev No: 4**

3. S11 VSWR Variation: (span 60MHz)

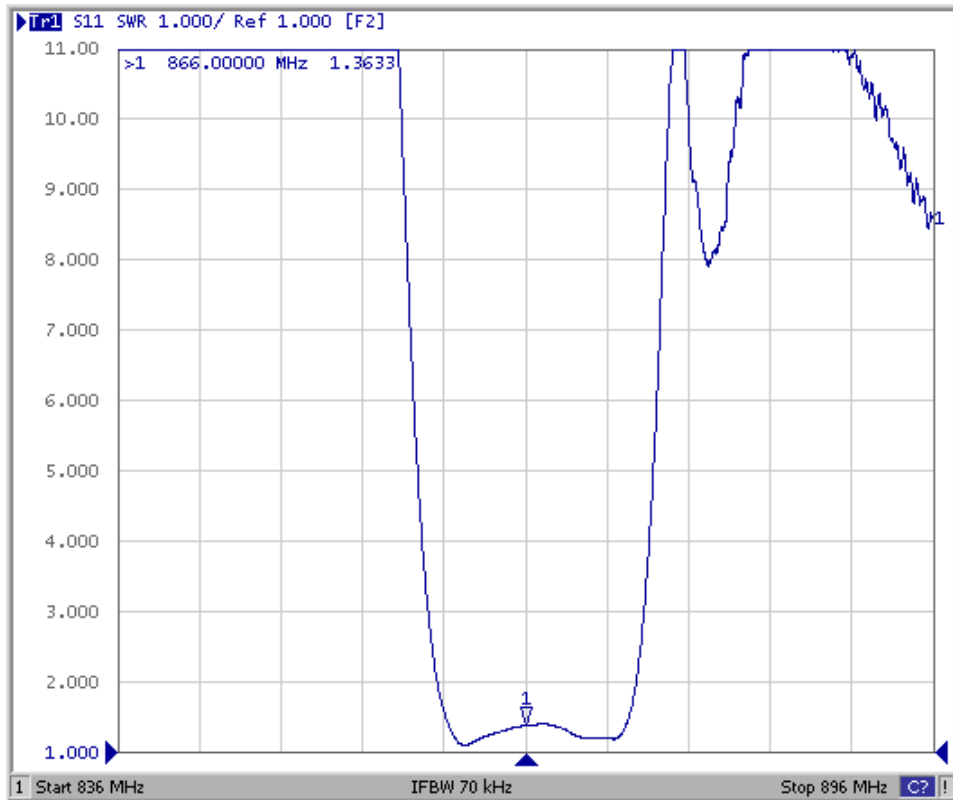

4. S22 VSWR Variation: (span 60MHz)

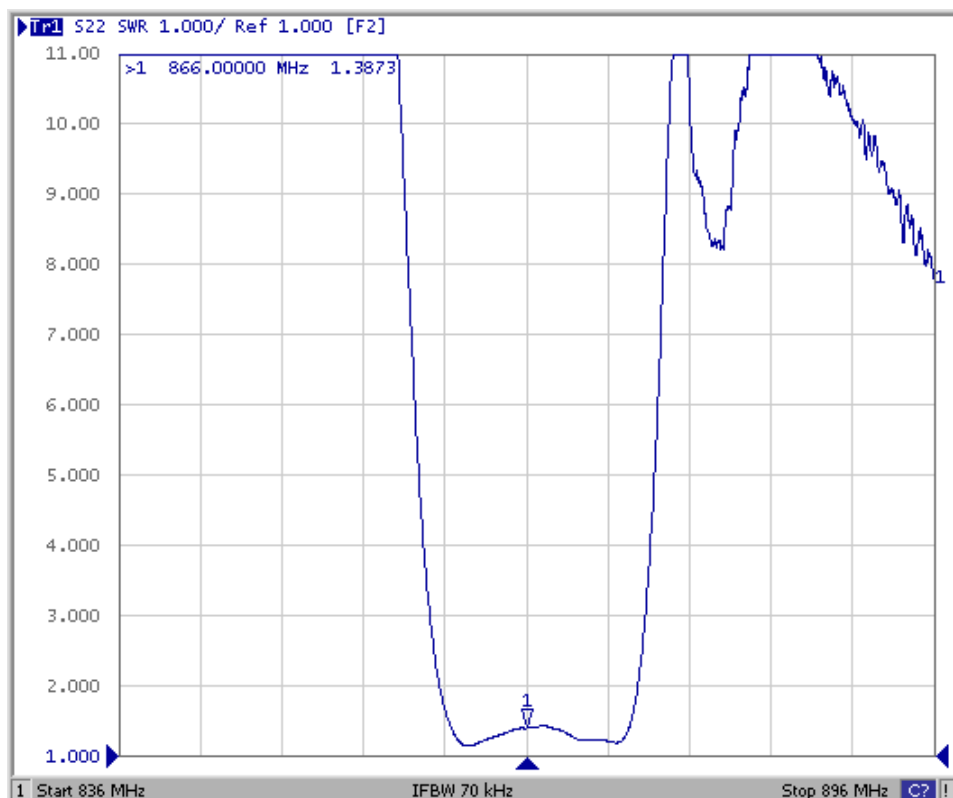

**SAW Filter 866.50MHz**  
**Part No: MP02248**

**Model No: TA0801A**  
**Rev No: 4**

**D. MEASUREMENT CIRCUIT:**

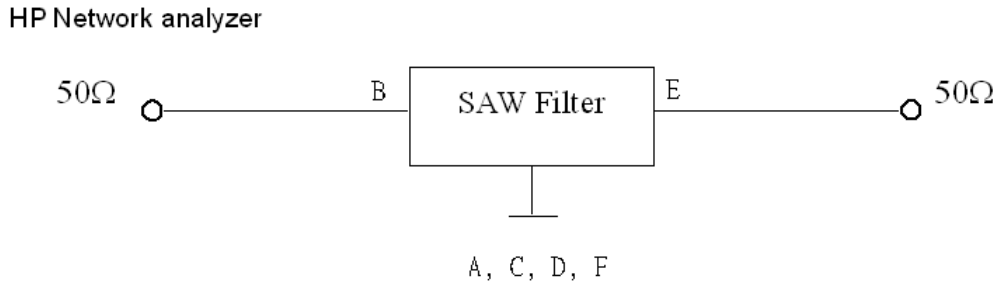

**E. OUTLINE DRAWING:**

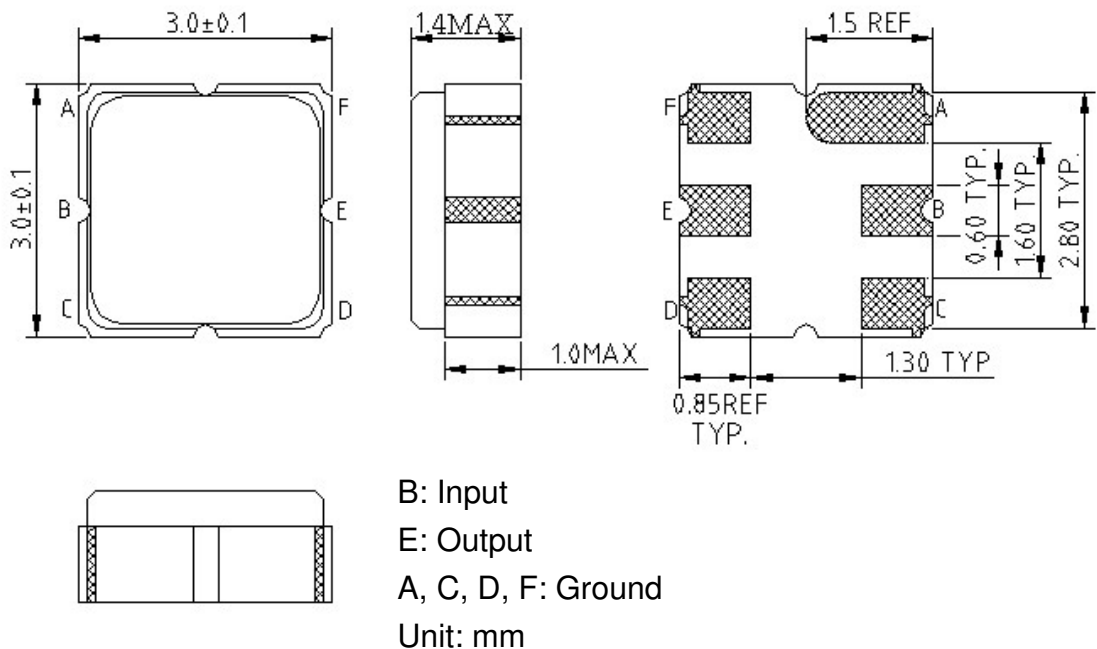

**F. PCB FOOTPRINT:**

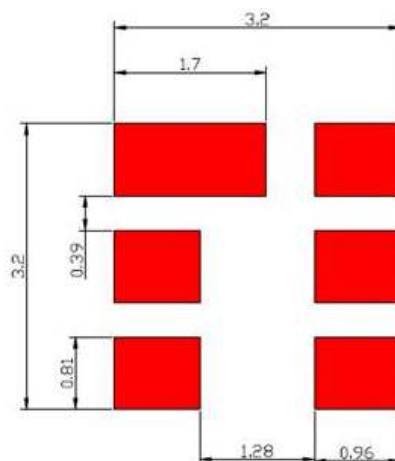

Fig.3 Desirable land area(in mm)

**SAW Filter 866.50MHz**  
**Part No: MP02248**

**Model No: TA0801A**  
**Rev No: 4**

**G. PACKING:**

1. Reel Dimension

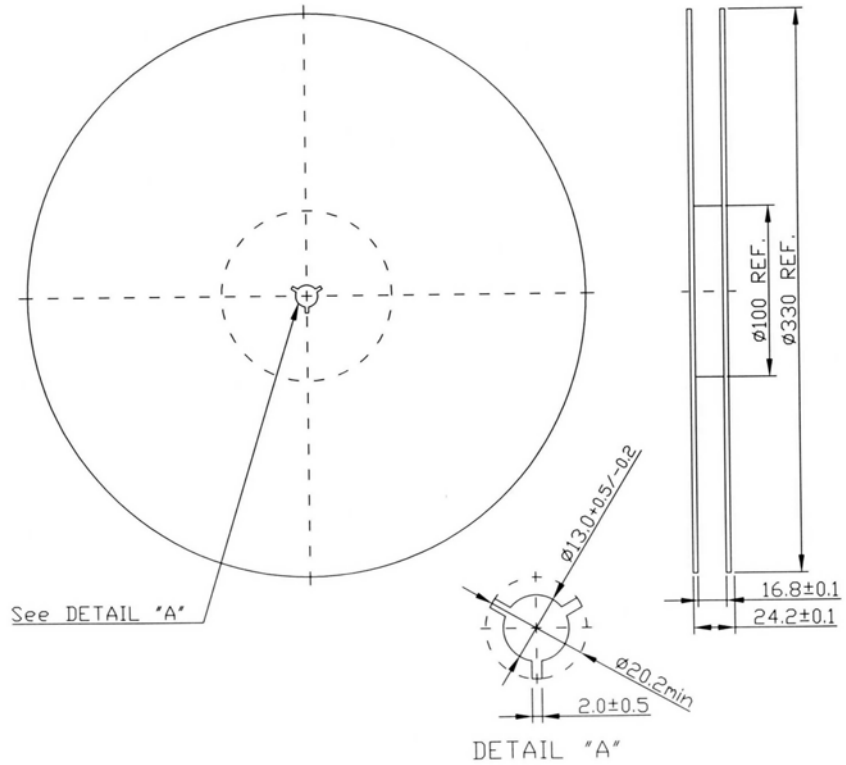

2. Tape Dimension

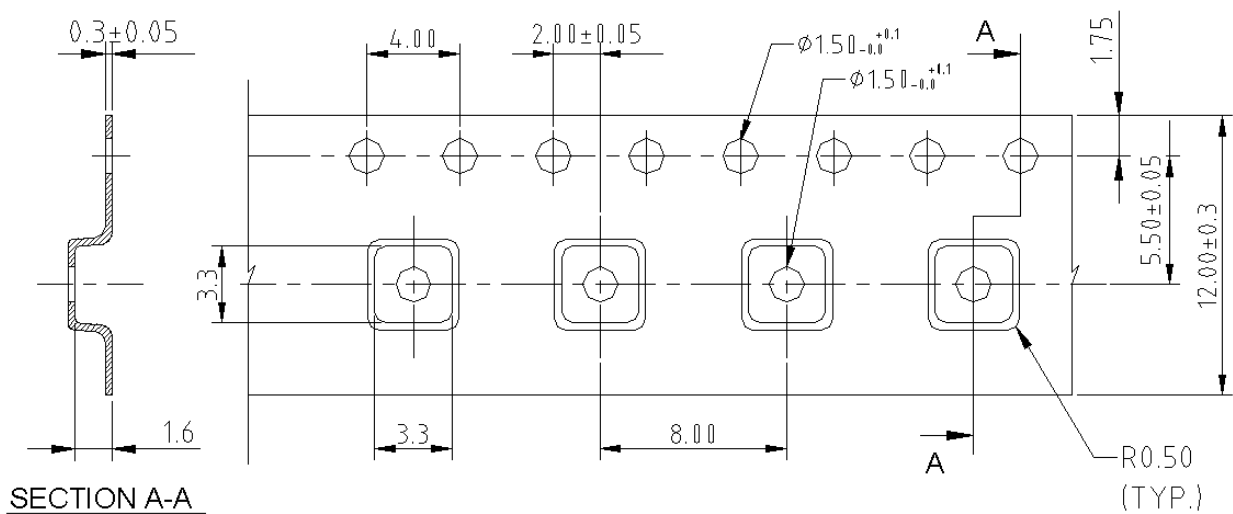

**SAW Filter 866.50MHz**  
**Part No: MP02248**

**Model No: TA0801A**  
**Rev No: 4**

**H. RECOMMENDED REFLOW PROFILE:**

1. Preheating shall be fixed at 150 ~ 180°C for 60 ~ 90 seconds.
2. Ascending time to preheating temperature 150°C shall be 30 seconds min.
3. Heating shall be fixed at 220°C for 50 ~ 80 seconds and at 260°C +0/-5°C peak (20 ~ 40 sec).
4. Time: 2 times.

