



LOC		DIST		REVISIONS			
P	LTR	DESCRIPTION	DATE	DNW	APVD		
P		ECO-15-016062	10NOV15	KG	CD		

- THIS RCPT. IS DESIGNED TO CONFORM TO THE LATEST ISSUE OF MIL-C-24308
  - MAX WIRE INSUL TO BE USED WITH THIS RCPT IS .054 DIA
  - METAL RETENTION CLIPS ARE INCLUDED IN INSERTS
  - PACKAGE MARKED M 24308/2-300F
  - THIS RCPT. WILL ACCEPT SIZE 22 SOCKET CONTACT M 24308/12 OR TE # 204351
-  MANUFACTURER'S PART NO. MARKED ON CONNECTOR REPRESENTS KIT NUMBER WITH CONTACTS  
 UL/CSA DESIGNATION MARKED IN THIS AREA, OPTIONAL

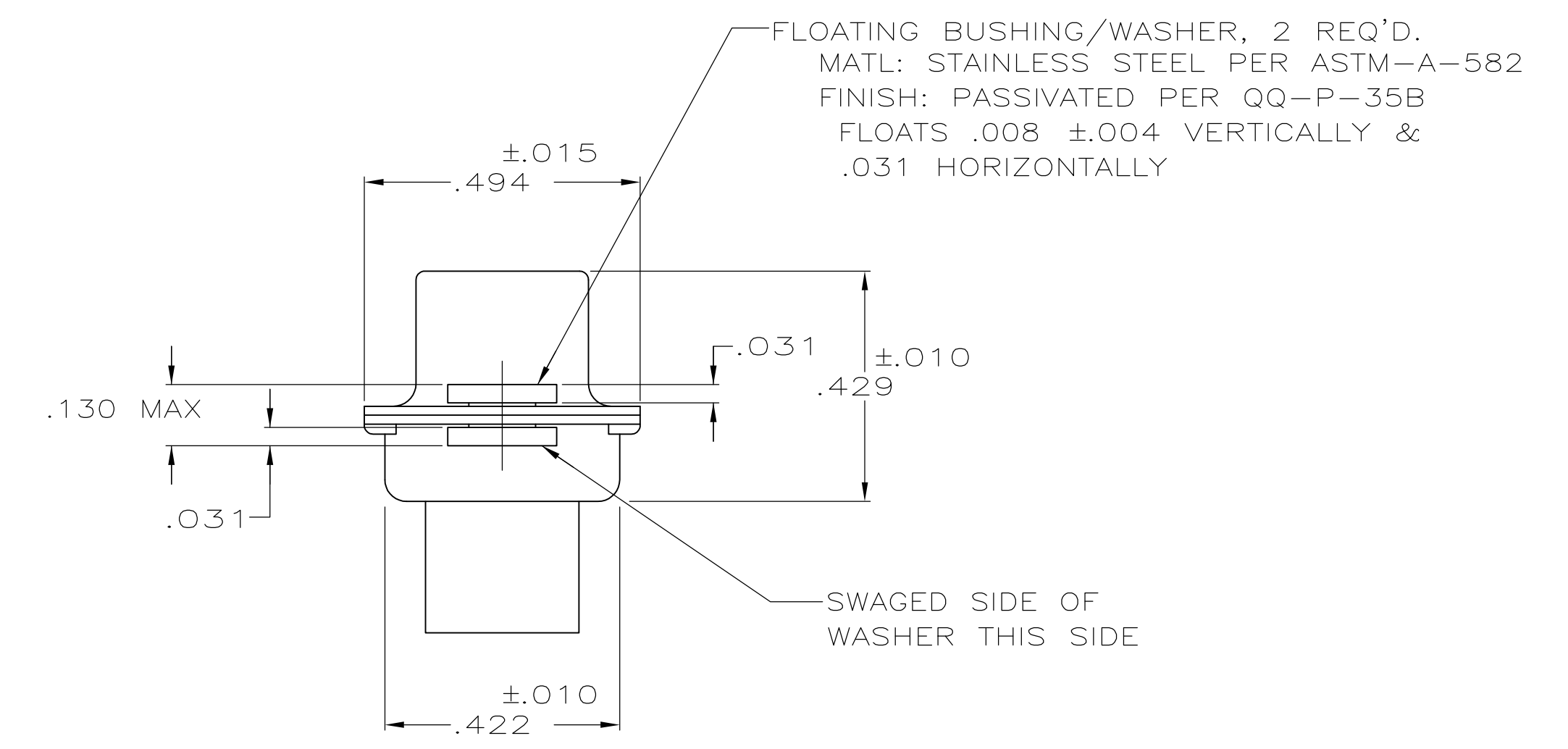
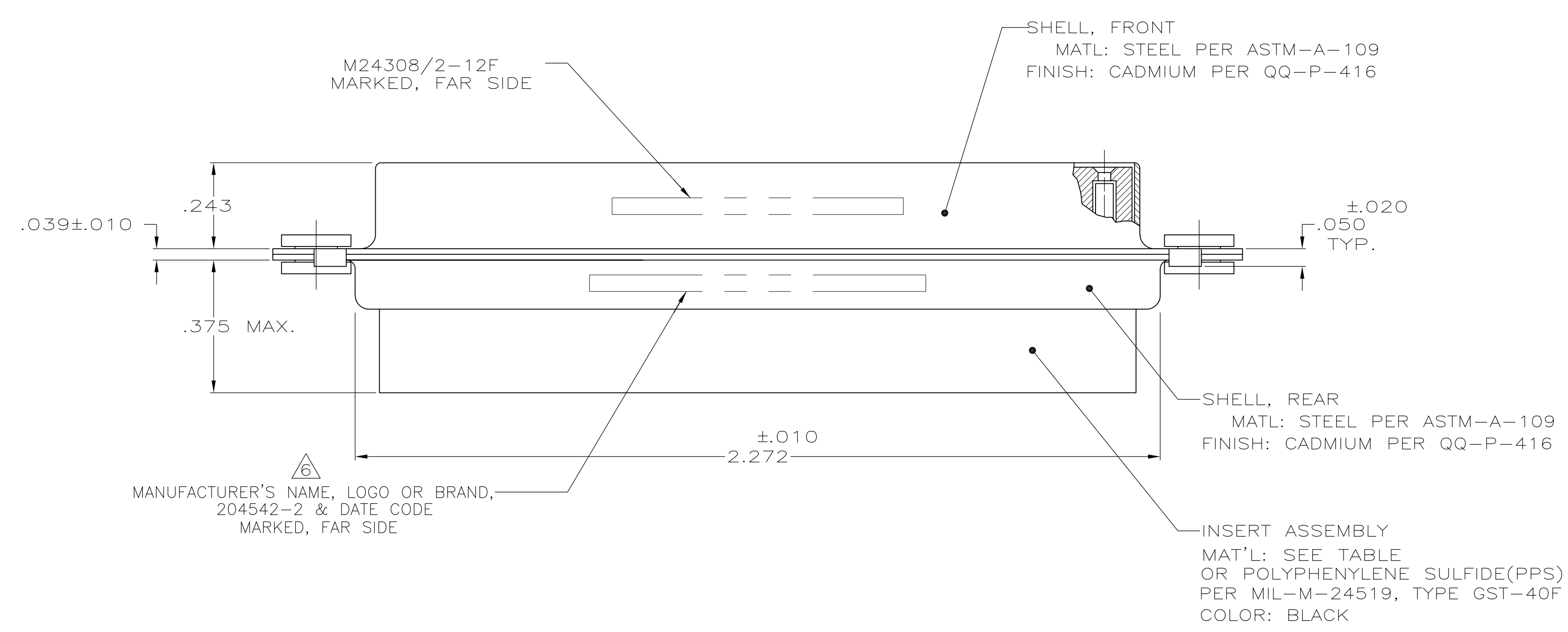
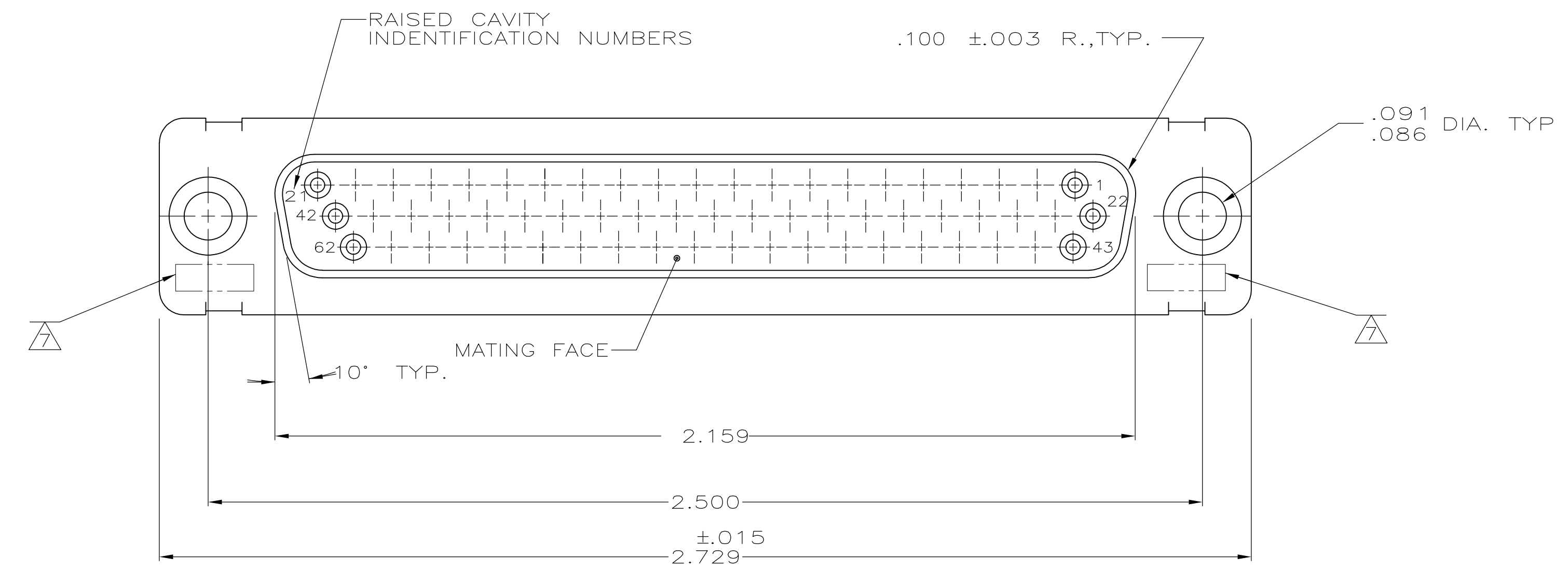

OBSOLETE	PHENOLIC COLOR: BLACK	204530-1
	DIALYL PHTHALETE COLOR: BLUE	204530-1
	INSERT MAT'L	PART NO

THIS DRAWING IS A CONTROLLED DOCUMENT.

DIMENSIONS: INCHES	TOLERANCES UNLESS OTHERWISE SPECIFIED:	DIN C.C. THOMAS 12-3-87	1-25-88
	0. PLC ± -	CHK F.C. BALLEW III	1-25-88
	1. PLC ± -	APVD F.C. BALLEW III	1-25-88
	2. PLC ± -	PRODUCT SPEC	
	3. PLC ± .005	APPLICATION SPEC	
	4. PLC ± -	SIZE	4
	ANGLES ± ° 30'	WEIGHT	
MATERIAL SEE CALLOUTS	FINISH SEE CALLOUTS	SCALE	4:1
		SHEET	1 OF 1
		REV	P

**STE** TE Connectivity  
 AMPLIMITE RCPT. FOR SOCKET CONTACTS  
 HI-DENSITY D CONNECTOR  
 SIZE 4, 62 POS., SERIES 90 WITH FLOAT BUSHINGS  
 A1 00779 C=204530  
 CUSTOMER DRAWING