

THIS DRAWING IS UNPUBLISHED. RELEASED FOR PUBLICATION
 © COPYRIGHT BY TYCO ELECTRONICS CORPORATION. ALL RIGHTS RESERVED.

CABLE ENTRY DIAMETER MINIMUM	
CONTACT	.021
HOUSING	.066
FERRULE	.126

LOC	DIST	REVISIONS			
P	LTR	DESCRIPTION	DATE	DWN	APVD
AJ	00	B	REV PER ECO 07-004710	3/12/2007	DW KW

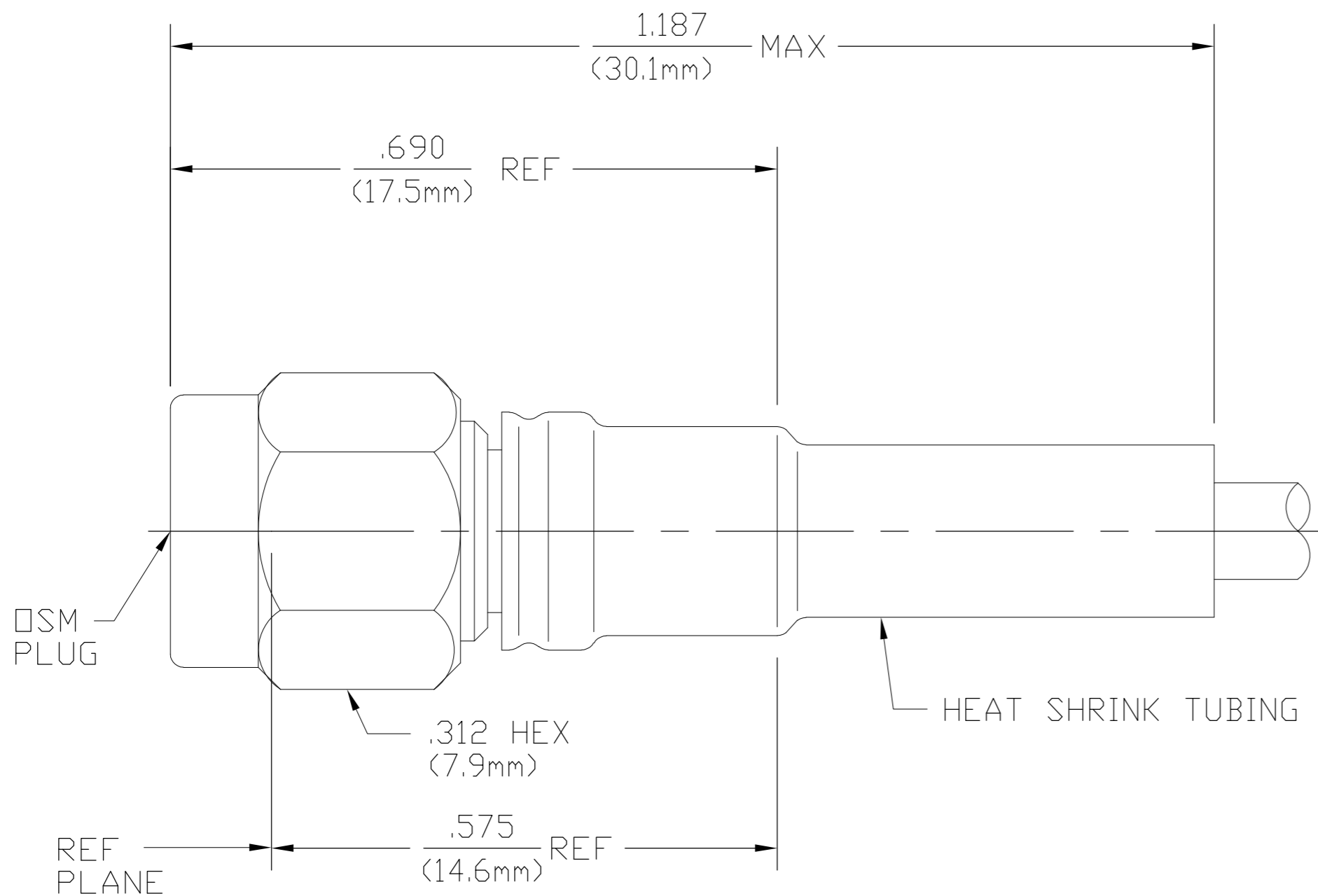

1051644-1
PART NUMBER

COMPONENT	MATERIAL	FINISH
HOUSING	STAINLESS STEEL PER ASTM-A484 AND ASTM-A582, TYPE 303	GOLD PLATE PER MIL-G-45204 OVER NICKEL PLATE PER QQ-N-290
COUPLING NUT	STAINLESS STEEL PER ASTM-A484 AND ASTM-A582, TYPE 303	PASSIVATE PER ASTM-A380
DIELECTRIC	TFE FLUOROCARBON PER ASTM-D-1457	N/A
CENTER CONTACT	BERYLLIUM COPPER PER ASTM B 196, ALLOY C17300, CONDITION H OR BRASS PER ASTM-B-16	GOLD PLATE PER MIL-G-45204 OVER COPPER PLATE PER MIL-C-14550
RETAINING RING	BERYLLIUM COPPER PER ASTM B 194, ALLOY C17200, CONDITION H	N/A
GASKET	SILICONE RUBBER PER ZZ-R-765	N/A
SHRINK TUBING	HEAT SHRINKABLE POLYOLEFIN COMPOUND MIL-I-23053/4	N/A
FERRULE	SOFT COPPER ALLOY	GOLD PLATE PER MIL-G-45204 OVER COPPER PLATE PER MIL-C-14550

ELECTRICAL	MECHANICAL	ENVIRONMENTAL
Nominal Impedance (Ohms) <u>50</u>	Interface Dimensions MIL-STD-348A, Fig. <u>310.1</u>	TEMPERATURE RATING <u>-65°C TO +165°C</u>
Frequency Range (GHz) DC to <u>12.4</u>	Recommended Mating Torque <u>7 TO 10 INCH/LBS</u>	Vibration MIL-STD-202, Method 204, Condition B
Volt Rating (VRMS MAX) @ Sea Level <u>250</u>	Mating Characteristics: Insertion (MAX Lbs) <u>N/A</u>	Shock MIL-STD-202, Method 213, Condition I
VSWR <u>1.15 + .02F(GHZ)</u>	Withdrawal (MIN Oz) <u>N/A</u>	Thermal Shock MIL-STD-202, Method 107, Condition C
Insertion Loss (dB MAX) <u>.06 √F(GHZ)@6GHZ</u>	Force to Engage and Disengage (In/Lbs MAX) <u>2.0</u>	Moisture Resistance MIL-STD-202, Method 106,
RF Leakage (dB MIN) <u>-60@ 6 to 8 GHZ</u>	Center Contact Captivation Axial (Lbs) <u>N/A</u>	Corrosion - MIL-STD-202, Method 101, Condition B, 5% salt spray
Corona, 70,000 Ft (VRMS MIN) <u>190</u>	Radial (In/Oz) <u>N/A</u>	
Dielectric Withstanding Voltage (VRMS MIN) @ Sea Level <u>750</u>	Cable Retention Axial Force (Lbs) <u>20</u>	
Contact Resistance (Milliohms MAX) Center Contact <u>3.0</u>	Torque (In/Oz) <u>N/A</u>	
Outer Contact <u>2.0</u>	Weight (Grams) <u>2.7</u>	
Cable to Housing <u>0.5</u>		
RF High Potential @ Sea Level (VRMS MIN @ 5 MHz) <u>500</u>		
I.R.(Megohms MIN) <u>5000</u>		

THIS DRAWING IS A CONTROLLED DOCUMENT.

DWN	DRF	10/12/76
CHK	KWW	2/17/77
APVD	BWC	2/18/77

tyco Electronics Tyco Electronics Corporation Harrisburg, PA 17105-3608

NAME: OSM STRAIGHT CABLE PLUG SOLDER ATTACHMENT

SIZE	CAGE CODE	DRAWING NO	RESTRICTED TO
A2	00779	1051644	-

CUSTOMER DRAWING SCALE 5:1 SHEET 1 of 1 REV B