



NXP Generation 2 USB Type-C Shield Board

USB Type-C Shield enables DisplayPort Alt-Mode, USB 3.1 Gen 1, OVP/OCP protection and 100 Watt bi-directional power switch

NXP's Generation 2.0 USB Type-C shield board, combined with MCUXpresso SDK and USB Power Delivery Stack, allows you to tether a USB Type-C connector to Kinetis, LPC, and i.MX RT Development Platforms. This shortens the learning curve by leveraging NXP's Easy-to-use hardware and MCUXpresso software and tools, the only solution like it on the market. It enables Type-C support for display port alt-mode with seamless effort and offers numerous voltage protection services, promising easy and effective designs.

KEY FEATURES

- ▶ Plug-and-play USB Type-C development kit
- ▶ MCUXpresso SDK with USB Power Delivery library
- ▶ Hardware and software setup guides

APPLICATIONS

- ▶ IoT
- ▶ TV/Monitor with DisplayPort Alt Mode
- ▶ USB Type-C Periphery devices

BENEFITS

- ▶ Total Solution: hardware, open source firmware, development environment with application example source codes
- ▶ Support USB Power Delivery 3.0, up to 100 Watt power*
- ▶ Over-voltage protection up to 28 V voltage for USB Type-C connector
- ▶ Arduino header for simple plug & play

DISPLAY PORT ALT-MODE

The USB Type-C Shield Gen 2 provide DisplayPort v1.2 (5.4 Gbps) and USB 3.1 Gen 1 (5 Gbps) over the Type-C connector. The USB Type-C Shield Gen 2 has host board that target video source and dock side video sink applications.

DEVELOPMENT PLATFORMS

The USB Type-C Shield Gen 2 combines with MCUXpresso IDE allow end users quickly develop end application with minimum effort for firmware and hardware porting.

* The USB Type-C Shield Gen 2 is intended for system development. Although the hardware and firmware setup can be configured to demo 100Watt SINK and SOURCE, the USB Type-C Shield Gen 2 PCB design is not intend for prolong use at 100watt.



HOST BOARD

The host board is a video source device over USB Type-C. It supports power source during power up default. Runtime configuration for power role swap and data role swap.



DOCK BOARD

The dock board is a video sink device (e.g. Display, Monitor). It supports power sink and dead battery start up during up default. Run time configuration for power role swap and data role swap.



VOLTAGE PROTECTION

The USB shield board also uses a TCPC PHY, an NXP USB 3.1 Signal Redriver, a high voltage VBUS power switch, and authentication IC. The high voltage VBUS power switch is combined to multiple power switches and a LDO for USB PD applications. The device includes a bi-directional high voltage power switch supporting both 20 V sink and source, a 5 V power switch, and a 100 mA LDO providing power supply for dead battery operation. NXP's high voltage VBUS power switch has UL certification.

SHIELD BOARD GENERATION 2.0 HOST BOARD BOM

Part #	Description	Status
PTN36502	USB 3.1 Gen 1 and DisplayPort v1.2 Combo Redriver	MP
PTN5110	USB PD TCPC PHY IC	MP
NX20P3483	Sink & Source Combo Load Switch	MP
NX20P0407	CC & SBU Protection IC	MP

SHIELD BOARD GENERATION 2.0 DOCK BOARD BOM

Part #	Description	Status
PTN36502	USB 3.1 Gen 1 and DisplayPort v1.2 Combo Redriver	MP
PTN5110	USB PD TCPC PHY IC	MP
NX20P3483	Sink & Source Combo Load Switch	MP
NX20P0407	CC & SBU Protection IC	MP

SHIELD 2 HOST BOARD

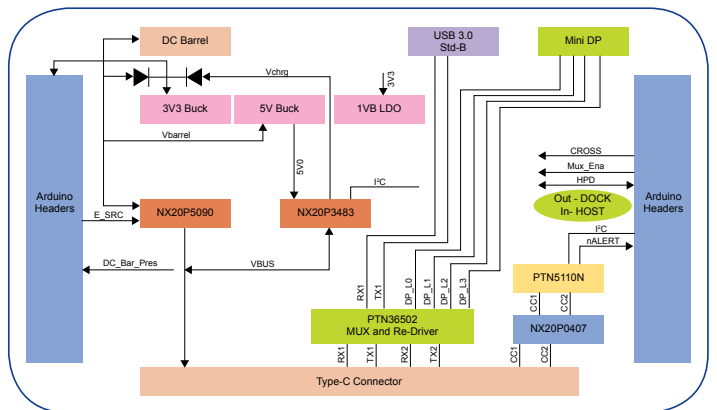

SHIELD 2 DOCK BOARD

