

REVISIONS					
REV	ECO	DESCRIPTION	DATE	BY	APPR
A1	-	FIRST RELEASE	Mar.30,2016	DRACK	TOMMY

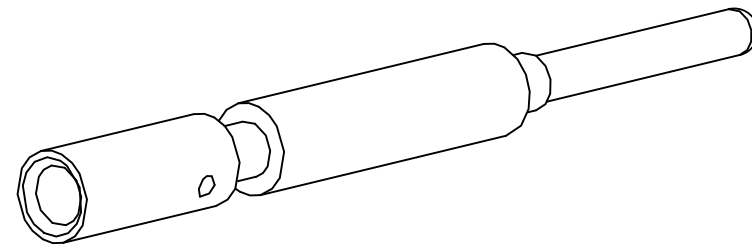
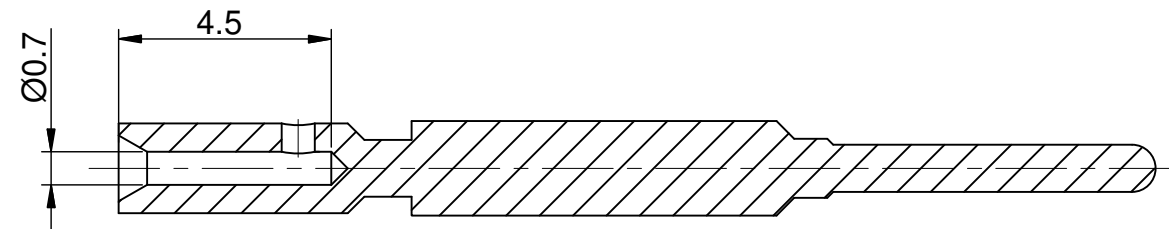
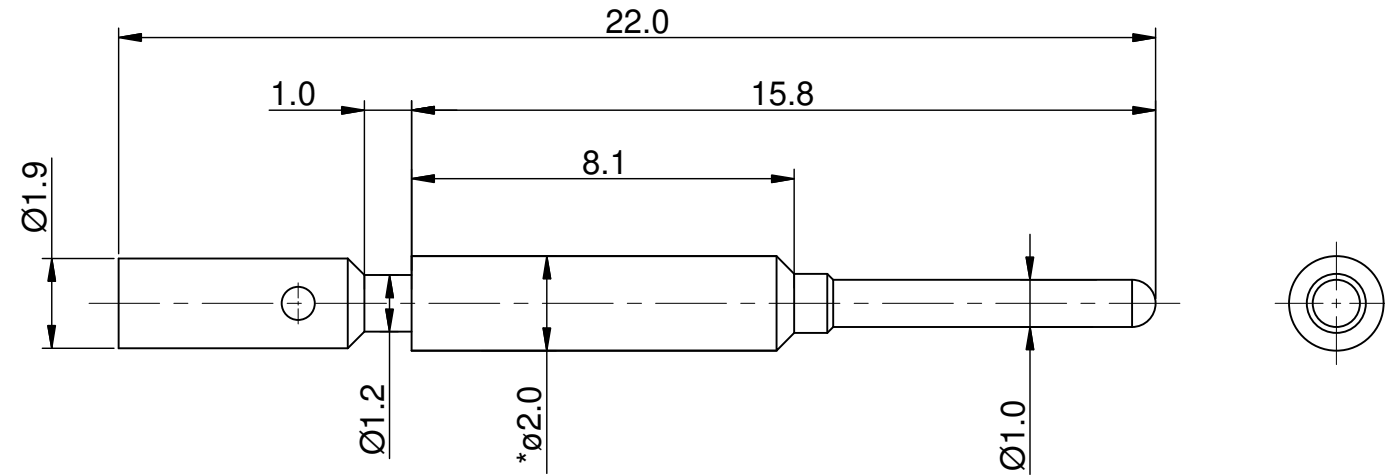

NOTES: UNLESS OTHERWISE SPECIFIED

1. MATERIAL: COPPER ALLOY, GOLD PLATED

2. SPECIFICATIONS:

2.1 RATED CURRENT: 10 AMPS

2.2 CONTACT RESISTANCE: <5 milliohm

2.3 AVAILABLE WIRE RANGE: 24AWG~28AWG

2.4 RoHS COMPLIANT

3. ALL DIMENSIONS ARE FOR REFERENCE USE ONLY.

TITLE: Pin contact, 1.0mm,Crimp 24-28AWG
 DWG NO: SC000386
 REV: A1
 SH: 1
 OF: 1

QUANTITY	SEE PART NUMBER CHART PART NUMBER	DESCRIPTION	ITEM
MATERIALS LIST			
UNLESS OTHERWISE SPECIFIED 1) All dimensions are in metric(mm). 2) Tolerances are as follows: 1 PL DEC ±0.30 2 PL DEC ±0.15 3 PL DEC ±0.08 Fractions ±1/64 Angles ±1° 3) Note reference =		SIGNATURES DRAWN: DRACK CHECKED: ENGINEER: APPROVAL: DATE: Mar.30,2016	Amphenol Sine Systems - www.amphenol-sine.com 44724 Morley Drive Clinton Township, MI 48036
MATERIAL SPECIFICATIONS:		CUSTOMER:	Pin contact,1.0mm,Crimp 24~28AWG
PROCESS SPECIFICATIONS:		THIS DRAWING IS SUPPLIED FOR INFORMATION ONLY. DESIGN FEATURES, SPECIFICATIONS AND PERFORMANCE DATA SHOWN HEREON ARE THE PROPERTY OF THE AMPHENOL CORPORATION. NO RIGHTS OF REPRODUCTION ARE IMPLIED. ALL DIMENSIONS ARE SUBJECT TO NORMAL MANUFACTURING VARIATIONS.	
NEXT ASSY:		SIZE: B TYPE: C- SCALE: NONE	DWG NO: SC000386 REVISION: A1 SHEET 1 OF 1