

FEATURES

7.5 GHz operating frequency
160 ps propagation delay
100 ps output rise/fall
110 fs random jitter
On-chip input terminations
Extended industrial temperature range: -40°C to $+125^{\circ}\text{C}$
3.3 V power supply ($V_{CC} - V_{EE}$)

APPLICATIONS

Clock and data signal restoration
High speed converter clocking
Broadband communications
Cellular infrastructure
High speed line receivers
ATE and high performance instrumentation
Level shifting
Threshold detection

GENERAL DESCRIPTION

The ADCLK914 is an ultrafast clock/data buffer fabricated on the Analog Devices, Inc., proprietary, complementary bipolar (XFCB-3) silicon-germanium (SiGe) process. The ADCLK914 features high voltage differential signaling (HVDS) outputs suitable for driving the latest Analog Devices high speed digital-to-analog converters (DACs). The ADCLK914 has a single, differential open-collector output.

The ADCLK914 buffer operates up to 7.5 GHz with a 160 ps propagation delay and adds only 110 fs random jitter (RJ).

FUNCTIONAL BLOCK DIAGRAM

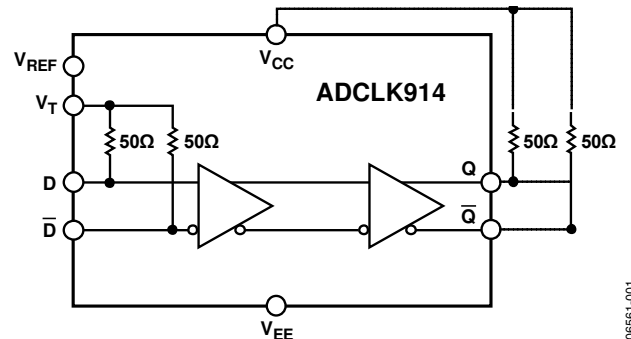

Figure 1.

101-06561-001

The input has a center tapped, 100 Ω , on-chip termination resistor and accepts LVPECL, CML, CMOS, LVTTTL, or LVDS (ac-coupled only). A V_{REF} pin is available for biasing ac-coupled inputs.

The HVDS output stage is designed to directly drive 1.9 V each side into 50 Ω terminated to V_{CC} for a total differential output swing of 3.8 V.

The ADCLK914 is available in a 16-lead LFCSP. It is specified for operation over the extended industrial temperature range of -40°C to $+125^{\circ}\text{C}$.

TABLE OF CONTENTS

Features	1	Typical Performance Characteristics	7
Applications	1	Applications Information	9
Functional Block Diagram	1	Power/Ground Layout and Bypassing	9
General Description	1	HVDS Output Stage	9
Table of Contents	2	Interfacing to High Speed DACs	9
Revision History	2	Optimizing High Speed Performance	9
Specifications	3	Random Jitter	9
Electrical Characteristics	3	Typical Application Circuits	10
Absolute Maximum Ratings	5	Outline Dimensions	11
Thermal Performance	5	Ordering Guide	11
ESD Caution	5		
Pin Configuration and Function Descriptions	6		

REVISION HISTORY

9/2017—Rev. A to Rev. B

Updated Outline Dimensions	11
Changes to Ordering Guide	11

10/2008—Rev. 0 to Rev. A

Changes to Input Low Voltage Parameter, Table 1	3
Changes to Output High Voltage Parameter, Table 1	3
Changes to Output Low Voltage Parameter, Table 1	3
Output Differential Range Parameter, Table 1	3
Changes to Absolute Maximum Ratings Section	5

7/2008—Revision 0: Initial Version

SPECIFICATIONS

ELECTRICAL CHARACTERISTICS

$V_{CC} = 3.3\text{ V}$, $V_{EE} = 0\text{ V}$, $T_A = -40^\circ\text{C}$ to $+125^\circ\text{C}$. All outputs terminated through $50\ \Omega$ to V_{CC} , unless otherwise noted.

Table 1.

Parameter	Symbol	Min	Typ	Max	Unit	Test Conditions/Comments	
DC INPUT CHARACTERISTICS							
Input High Voltage	V_{IH}	$V_{EE} + 1.65$		V_{CC}	V		
Input Low Voltage	V_{IL}	V_{EE}		$V_{CC} - 0.2$	V		
Input Differential Range	V_{ID}	0.2		3.4	V p-p	$T_A = -40^\circ\text{C}$ to $+85^\circ\text{C}$ ($\pm 1.7\text{ V}$ between input pins)	
		0.2		2.8	V p-p	$T_A = 85^\circ\text{C}$ to 125°C ($\pm 1.4\text{ V}$ between input pins)	
Input Capacitance	C_{IN}		0.4		pF		
Input Resistance			50		Ω		
Differential Mode			100		Ω		
Common Mode			50		k Ω	Open termination	
Input Bias Current			20		μA		
DC OUTPUT CHARACTERISTICS							
Output High Voltage	V_{OH}	$V_{CC} - 0.55$	$V_{CC} - 0.40$	$V_{CC} - 0.25$	V		
Output Low Voltage	V_{OL}	$V_{CC} - 2.75$	$V_{CC} - 2.35$	$V_{CC} - 1.9$	V		
Output Differential Range	V_{OD}	1.54	1.95	2.22	V		
Reference Voltage	V_{REF}				V		
Output Voltage			$(V_{CC} + 1)/2$		V	$-500\ \mu\text{A}$ to $+500\ \mu\text{A}$	
Output Resistance			250		Ω		
AC PERFORMANCE							
Operating Frequency			7.5		GHz	$> 1.1\text{ V}$ differential output swing, $V_{CC} = 3.3\text{ V} \pm 10\%$	
Propagation Delay	t_{PD}	127	158	202	ps	$V_{CC} = 3.3\text{ V} \pm 10\%$, $V_{ICM} = V_{REF}$, $V_{ID} = 1.6\text{ V p-p}$	
Propagation Delay Temperature Coefficient			140		fs/ $^\circ\text{C}$		
Propagation Delay Skew (Device to Device)				65	ps	$V_{ID} = 1.6\text{ V p-p}$	
Output Rise Time	t_R		100	125	ps	20%/80%	
Output Fall Time	t_F		80	95	ps	80%/20%	
Wideband Random Jitter ¹	RJ		110		fs rms	$V_{ID} = 1.6\text{ V p-p}$, 6 V/ns , $V_{ICM} = 1.85\text{ V}$	
Additive Phase Noise			622.08 MHz	-132		dBc/Hz	@10 Hz offset
				-143		dBc/Hz	@100 Hz offset
				-151		dBc/Hz	@1 kHz offset
				-156		dBc/Hz	@10 kHz offset
				-157		dBc/Hz	@100 kHz offset
				-156		dBc/Hz	>1 MHz offset
			245.76 MHz	-133		dBc/Hz	@10 Hz offset
				-143		dBc/Hz	@100 Hz offset
				-153		dBc/Hz	@1 kHz offset
				-158		dBc/Hz	@10 kHz offset
	-159		dBc/Hz	@100 kHz offset			
	-158		dBc/Hz	>1 MHz offset			

Parameter	Symbol	Min	Typ	Max	Unit	Test Conditions/Comments	
122.88 MHz			-150			dBc/Hz	@10 Hz offset
			-156			dBc/Hz	@100 Hz offset
			-160			dBc/Hz	@1 kHz offset
			-161			dBc/Hz	@10 kHz offset
			-161			dBc/Hz	@100 kHz offset
			-160			dBc/Hz	>1 MHz offset
POWER SUPPLY							
Supply Voltage Requirement	V_{CC}	2.97		3.63	V		
Power Supply Current							
Negative Supply Current	I_{VEE}	66	111	150	mA	Includes output current	
Positive Supply Current	I_{VCC}	34	55	73	mA		
Power Supply Rejection ²	PSR_{VCC}		13		ps/V	$V_{CC} = 3.3\text{ V} \pm 10\%$	
Output Swing Supply Rejection ³			-15		dB	$V_{CC} = 3.3\text{ V} \pm 10\%$	

¹ Calculated from SNR of ADC method. See Figure 8 for rms jitter vs. input slew rate.

² Change in t_{PD} per change in V_{CC} .

³ Change in output swing per change in V_{CC} .

ABSOLUTE MAXIMUM RATINGS

Table 2.

Parameter	Rating
Supply Voltage (V_{CC} to GND)	6.0 V
Input Voltage	-0.5 V to $V_{CC} + 0.5$ V
Maximum Output Voltage	$V_{CC} + 0.5$ V
Minimum Output Voltage	$V_{EE} - 0.5$ V
Input Termination	± 2 V
Voltage Reference	$V_{CC} - V_{EE}$
Operating Temperature Range, Ambient	-40°C to +125°C
Operating Temperature, Junction	150°C
Storage Temperature Range	-65°C to +150°C

Stresses at or above those listed under Absolute Maximum Ratings may cause permanent damage to the product. This is a stress rating only; functional operation of the product at these or any other conditions above those indicated in the operational section of this specification is not implied. Operation beyond the maximum operating conditions for extended periods may affect product reliability.

THERMAL PERFORMANCE

The ADCLK914 is specified for a case temperature (T_{CASE}). To ensure that T_{CASE} is not exceeded, use an airflow source.

To determine the junction temperature on the application PCB

$$T_J = T_{CASE} + (\Psi_{JT} \times PD)$$

where:

T_J is the junction temperature (°C).

T_{CASE} is the case temperature (°C) measured by the customer at top center of package.

Ψ_{JT} is determined by the values listed in Table 3.

PD is the power dissipation.

Values of θ_{JA} are provided for package comparison and PCB design considerations. θ_{JA} can be used for a first-order approximation of T_J by the equation

$$T_J = T_A + (\theta_{JA} \times PD)$$

where T_A is the ambient temperature (°C).

Values of θ_{JB} are provided for package comparison and PCB design considerations.

Table 3. Thermal Parameters for ADCLK914 16-Lead LFCSP

Symbol	Description ¹	Value	Units
θ_{JA}	Junction-to-ambient thermal resistance, 0.0 meters per sec air flow per JEDEC JESD51-2 (still air)	78.4	°C/W
θ_{JMA}	Junction-to-ambient thermal resistance, 1.0 meter per sec air flow per JEDEC JESD51-6 (moving air)	68.5	°C/W
θ_{JMA}	Junction-to-ambient thermal resistance, 2.5 m/s air flow per JEDEC JESD51-6 (moving air)	61.4	°C/W
θ_{JB}	Junction-to-board thermal resistance, 1.0 meter per sec air flow per JEDEC JESD51-8 (moving air)	48.8	°C/W
θ_{JC}	Junction-to-case thermal resistance (die-to-heatsink) per MIL-Std 883, Method 1012.1	1.5	°C/W
Ψ_{JT}	Junction-to-top-of-package characterization parameter, 0 meters per sec air flow per JEDEC JESD51-2 (still air)	2.0	°C/W

¹ Descriptions based on using a 2s2p test board.

ESD CAUTION



ESD (electrostatic discharge) sensitive device. Charged devices and circuit boards can discharge without detection. Although this product features patented or proprietary protection circuitry, damage may occur on devices subjected to high energy ESD. Therefore, proper ESD precautions should be taken to avoid performance degradation or loss of functionality.

PIN CONFIGURATION AND FUNCTION DESCRIPTIONS

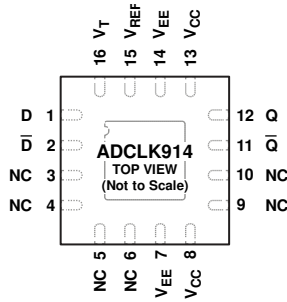

NOTES

1. NC = NO CONNECT. NO PHYSICAL CONNECTION TO THE DIE.
2. EXPOSED PAD. NO CONNECT. THE METALLIC BACK SURFACE OF THE PACKAGE IS NOT ELECTRICALLY CONNECTED TO ANY PART OF THE CIRCUIT. IT CAN BE LEFT FLOATING FOR OPTIMAL ELECTRICAL ISOLATION BETWEEN THE PACKAGE HANDLE AND THE SUBSTRATE OF THE DIE. IT CAN ALSO BE SOLDERED TO GROUND ON THE APPLICATION BOARD IF IMPROVED THERMAL AND/OR MECHANICAL STABILITY IS NEEDED. EXPOSED METAL AT THE CORNERS OF THE PACKAGE IS CONNECTED TO THIS BACK SURFACE. ALLOW SUFFICIENT CLEARANCE FOR VIAS AND OTHER COMPONENTS.

09581-002

Figure 2. Pin Configuration

Table 4. Pin Function Descriptions

Pin No.	Mnemonic	Description
1	D	Noninverting Input.
2	\overline{D}	Inverting Input.
3, 4, 5, 6, 9, 10	NC	No Connect. No physical connection to the die.
7, 14	V_{EE}	Negative Supply Voltage.
8, 13	V_{CC}	Positive Supply Voltage.
11	\overline{Q}	Inverting Output.
12	Q	Noninverting Output.
15	V_{REF}	Reference Voltage. Reference voltage for biasing ac-coupled inputs.
16	V_T	Center Tap. Center tap of 100 Ω input resistor.
Heat Sink/ Exposed Pad	NC	No Connect. The metallic back surface of the package is not electrically connected to any part of the circuit. It can be left floating for optimal electrical isolation between the package handle and the substrate of the die. It can also be soldered to ground on the application board if improved thermal and/or mechanical stability is needed. Exposed metal at the corners of the package is connected to this back surface. Allow sufficient clearance for vias and other components.

TYPICAL PERFORMANCE CHARACTERISTICS

$V_{CC} = 3.3\text{ V}$, $V_{EE} = 0\text{ V}$, $T_A = 25^\circ\text{C}$. All outputs terminated through $50\ \Omega$ to V_{CC} , unless otherwise noted.

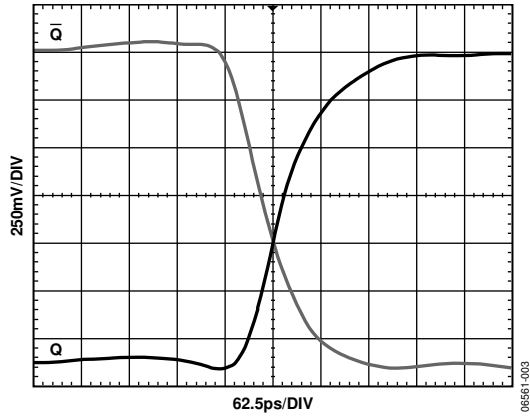

Figure 3. Output Waveform at 1 GHz, $V_{CC} = 3.3\text{ V}$

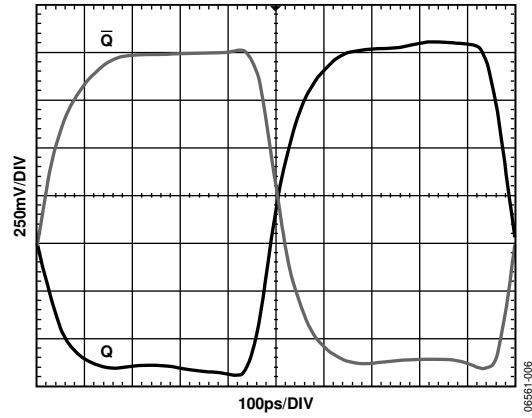

Figure 6. Output Waveform at 1 GHz, $V_{CC} = 3.3\text{ V}$

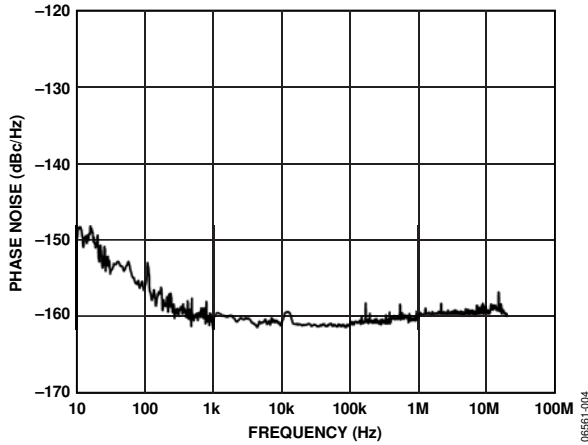

Figure 4. Phase Noise at 122.88 MHz

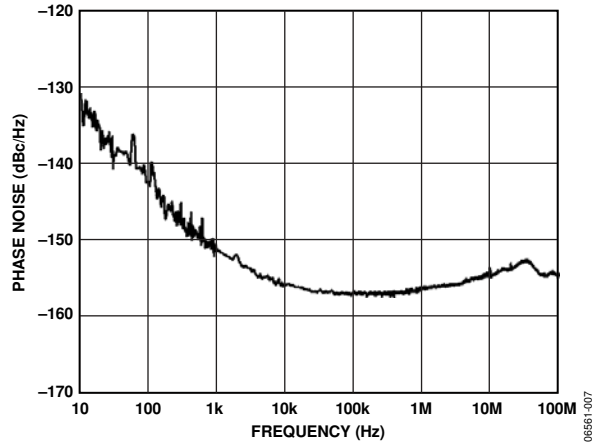

Figure 7. Phase Noise at 622.08 MHz

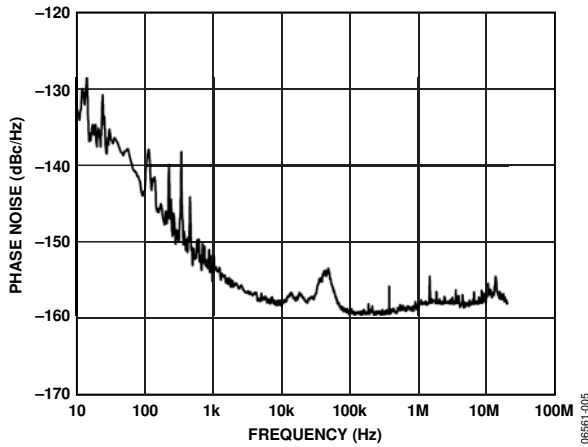

Figure 5. Phase Noise at 245.76 MHz

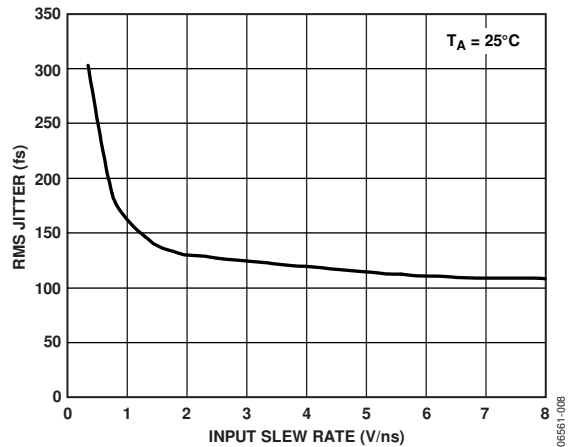

Figure 8. RMS Jitter vs. Input Slew Rate

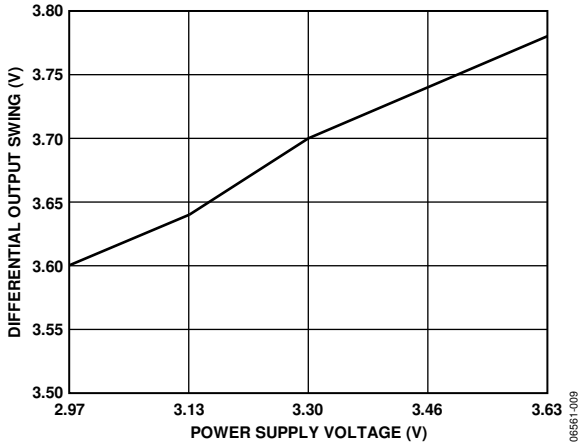

Figure 9. Differential Output Swing vs. Power Supply Voltage

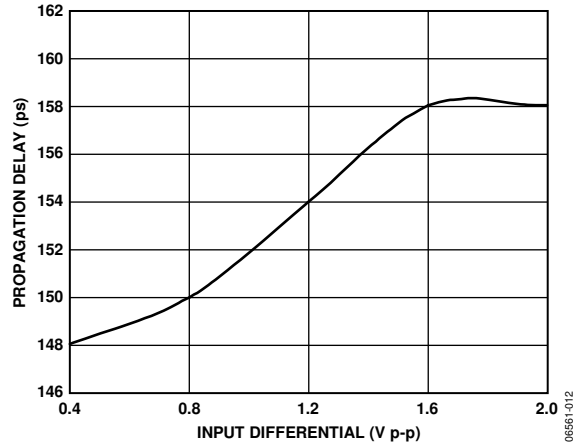

Figure 12. Propagation Delay vs. V_{ID} ; $V_{ICM} = 2.15 V$

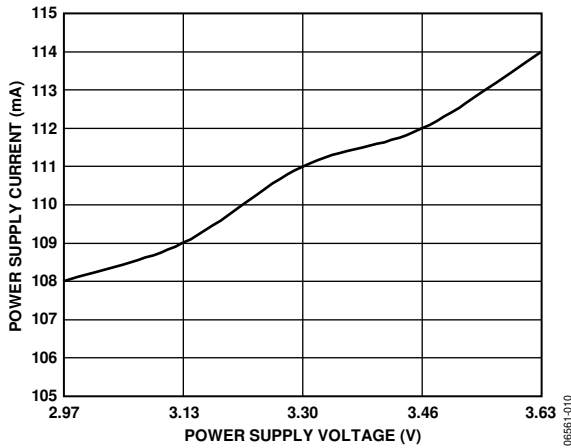

Figure 10. Power Supply Current vs. Power Supply Voltage

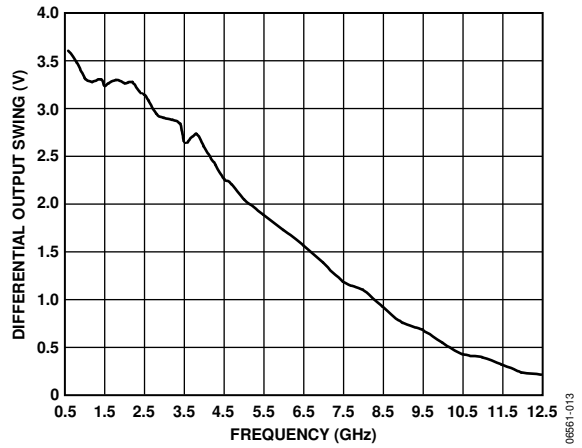

Figure 13. Toggle Rate, Differential Output Swing vs. Frequency

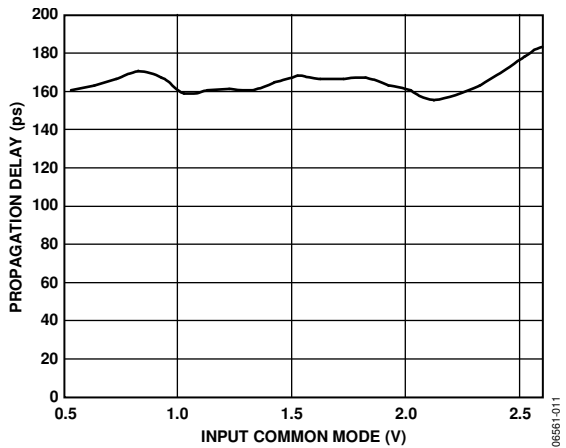

Figure 11. Propagation Delay vs. V_{ICM} ; $V_{ID} = 1.6 V p-p$

APPLICATIONS INFORMATION

POWER/GROUND LAYOUT AND BYPASSING

The ADCLK914 buffer is designed for very high speed applications. Consequently, high speed design techniques must be used to achieve the specified performance. It is critically important to use low impedance supply planes for both the negative supply (V_{EE}) and the positive supply (V_{CC}) planes as part of a multilayer board. Providing the lowest inductance return path for switching currents ensures the best possible performance in the target application.

It is also important to adequately bypass the input and output supplies. Place a 1 μF electrolytic bypass capacitor within several inches of each power supply pin to ground. In addition, place multiple high quality 0.001 μF bypass capacitors as close as possible to each V_{EE} and V_{CC} supply pin and connect these capacitors to the GND plane with redundant vias. Carefully select high frequency bypass capacitors for minimum inductance and ESR. To maximize the effectiveness of the bypass capacitors at high frequencies, strictly avoid parasitic layout inductance.

Slew currents may also appear at the V_{DD} and V_{SS} pins of the device being driven by the ADCLK914.

HVDS OUTPUT STAGE

The ADCLK914 has been developed to provide a bipolar interface to any CMOS device that requires extremely low jitter, high amplitude clocks. It is intended to be placed as close as possible to the receiving device and allows the rest of the clock distribution to run at standard CML or PECL levels.

Interconnects must be short and very carefully designed because the single terminated design provides much less margin for error than lower voltage, double terminated transmission techniques.

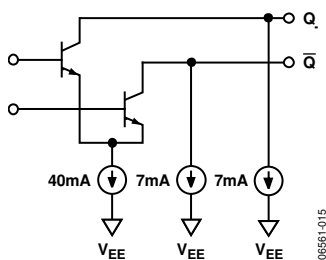

Figure 14. Simplified Schematic Diagram of the ADCLK914 HVDS Output Stage

INTERFACING TO HIGH SPEED DACs

The ADCLK914 is designed to drive high amplitude, low jitter clock signals into high speed, multi-GSPS DACs. The ADCLK914 should be placed as close as possible to the clock input of the DAC so that the high slew rate and high amplitude clock signal that these devices require do not cause routing difficulties, generate EMI, or become degraded by dielectric and other

losses. The ADCLK914, in turn, may be driven directly by standard or low swing PECL, CML, CMOS, or LVTTTL sources, or by LVDS with simple ac coupling, as illustrated in Figure 15 through Figure 19.

OPTIMIZING HIGH SPEED PERFORMANCE

As with any high speed circuit, proper design and layout techniques are essential to obtaining the specified performance. Stray capacitance, inductance, inductive power, and ground impedances, as well as other layout issues, can severely limit performance and can cause oscillation. Discontinuities along input and output transmission lines can also severely limit the specified jitter performance by reducing the effective input slew rate.

Input and output matching have a significant impact on performance. The ADCLK914 buffer provides internal 50 Ω termination resistors for both D and \bar{D} inputs. The return side can be connected to the reference pin provided or to a current sink at $V_{CC} - 2\text{V}$ for use with differential PECL, or to V_{CC} for direct coupled CML. The V_{REF} pin should be left floating any time that it is not used to minimize power consumption.

Note that the ADCLK914 V_{REF} source is current-limited to resist damage from momentary shorts to V_{EE} or V_{CC} and from capacitor charging currents; for this reason, the V_{REF} source cannot be used as a PECL termination supply.

Carefully bypass the termination potential using ceramic capacitors to prevent undesired aberrations on the input signal due to parasitic inductance in the termination return path. If the inputs are directly coupled to a source, care must be taken to ensure that the pins remain within the rated input differential and common-mode ranges.

If the return is floated, the device exhibits 100 Ω cross-termination, but the source must then control the common-mode voltage and supply the input bias currents.

ESD/clamp diodes between the input pins prevent the application of excessive offsets to the input transistors. ESD diodes are not optimized for best ac performance. If a clamp is needed, it is recommended that appropriate external diodes be used.

RANDOM JITTER

The ADCLK914 buffer has been specifically designed to minimize random jitter over a wide input range. Provided that sufficient voltage swing is present, random jitter is affected most by the slew rate of the input signal. Whenever possible, clamp excessively large input signals with fast Schottky diodes because attenuators reduce the slew rate. Input signal runs of more than a few centimeters should be over low loss dielectrics or cables with good high frequency characteristics.

TYPICAL APPLICATION CIRCUITS

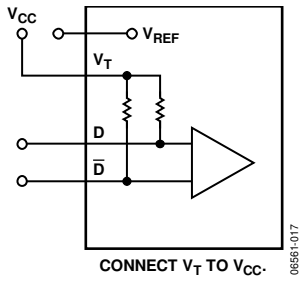

Figure 15. Interfacing to CML Inputs

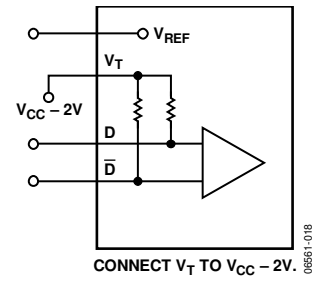
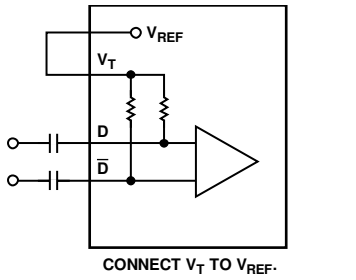

Figure 18. Interfacing to ECL Inputs



NOTES
1. PLACING A BYPASS CAPACITOR FROM V_T TO GROUND CAN IMPROVE THE NOISE PERFORMANCE.

Figure 16. AC Coupling Differential Signals

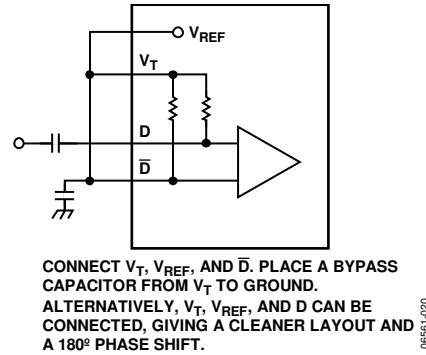

Figure 19. Interfacing to AC-Coupled, Single-Ended Inputs

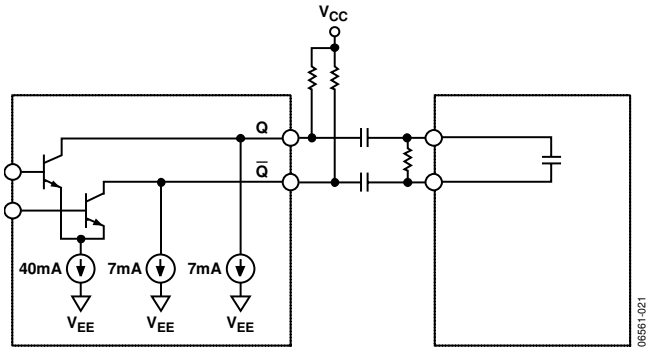
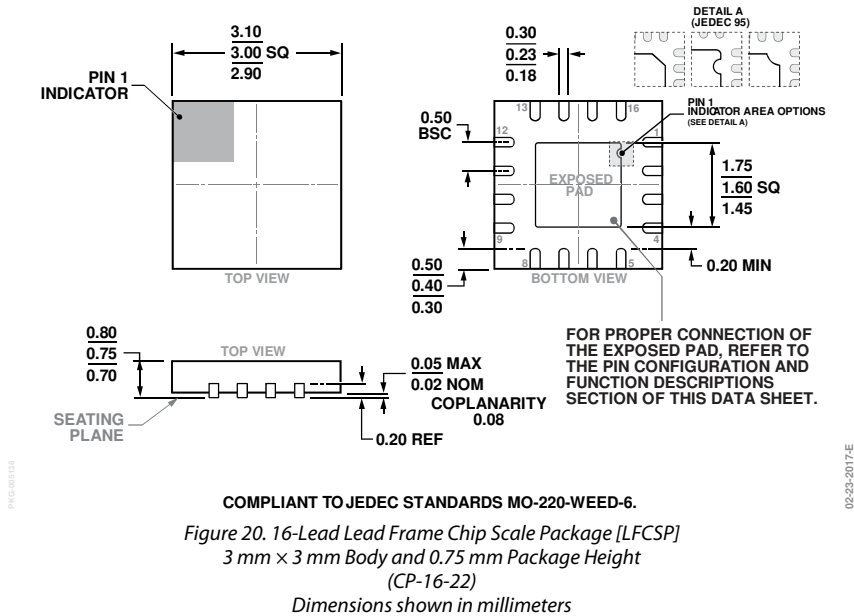

Figure 17. Interfacing to High Speed DAC

OUTLINE DIMENSIONS



ORDERING GUIDE

Model ¹	Temperature Range	Package Description	Package Option
ADCLK914BCPZ-WP	-40°C to +125°C	16-Lead Lead Frame Chip Scale Package [LFCSP]	CP-16-22
ADCLK914BCPZ-R7	-40°C to +125°C	16-Lead Lead Frame Chip Scale Package [LFCSP]	CP-16-22
ADCLK914BCPZ-R2	-40°C to +125°C	16-Lead Lead Frame Chip Scale Package [LFCSP]	CP-16-22
ADCLK914/PCBZ		Evaluation Board	

¹ Z = RoHS Compliant Part.