

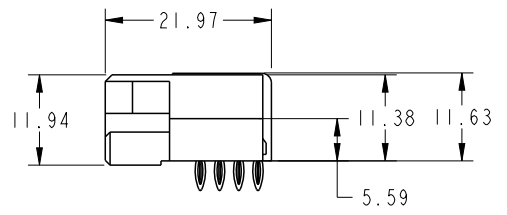

Copyright FCI.

PRODUCT NO.	ROWS	POW	S	POW		
51915-418-- NOTE 3	D C B A	E2	P2	1	P1	E1
		PF	SRPN	PE		

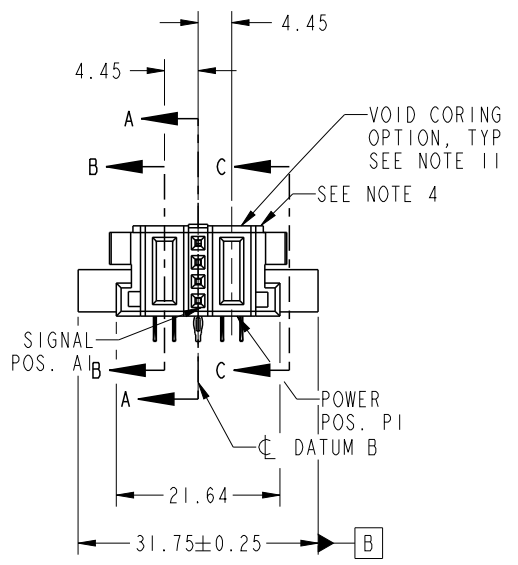
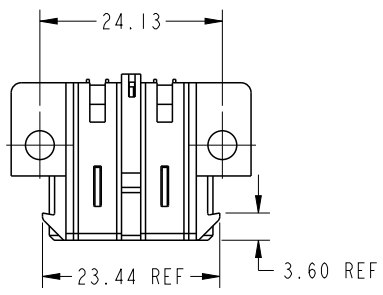

CODE	DIM "M" MATING LENGTH	CONTACT TYPE
PF	[2.34]	POWER
PE	[1.07]	POWER
S	[N/A]	SIGNAL
R	[N/A]	SIGNAL
P	[N/A]	SIGNAL
N	[N/A]	SIGNAL

spec ref	SEE NOTES		
tolerance std	TOLERANCES UNLESS OTHERWISE SPECIFIED		
SEE NOTES	linear	0.X	±0.50
		0.XX	±0.25
		0.XXX	±0.10
surface	angular	0°	±2°

dr	Luo Weller	2013/10/30
eng	Luo Weller	2013/11/19
chr	-	-
appr	Pei-Ming Zheng	2013/11/19

projection	MM	size	A4	scale	1:1
product family	PwrBlade		ecn no	-	
		rel level	Released		

FCI logo	title	IP+4S+IP R/A PF RECEPTACLE	dwg no	51915-418	rev	A
www.fci.com	cat. no.	Product - Customer Drw	sheet 1 of 4			

PrdrE File - REV C - 2009-06-09

PRODUCT NUMBER

51915-418\_  
NOTE 3

0.25 REF

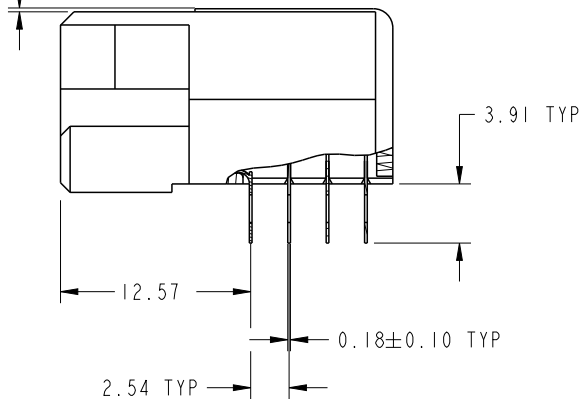

BROKEN-OUT SECTION A-A  
SCALE 2:1

DIM "M" ±0.25

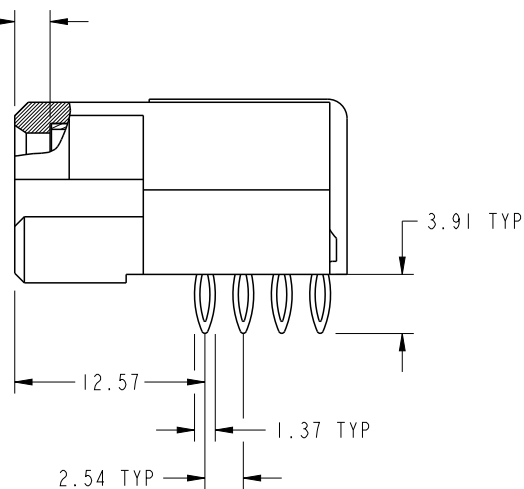

BROKEN-OUT SECTION B-B  
SCALE 2:1

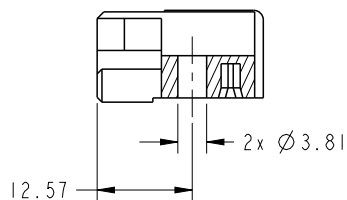

SECTION C-C

dr	Luo Weller	2013/10/30	projection 	MM 	size	A4	scale	1:1	
eng	Luo Weller	2013/11/19			ecn no	-			
chr	-	-			rel level	Released			
appr	Pei-Ming Zheng	2013/11/19	product family	PwrBlade					
		title	IP+4S+IP R/A PF RECEPTACLE		dwg no	51915-418		rev	A
www.fci.com		cat. no.	Product - Customer Drw			sheet 2 of 4			

PRODUCT NUMBER

51915-418\_\_  
NOTE 3

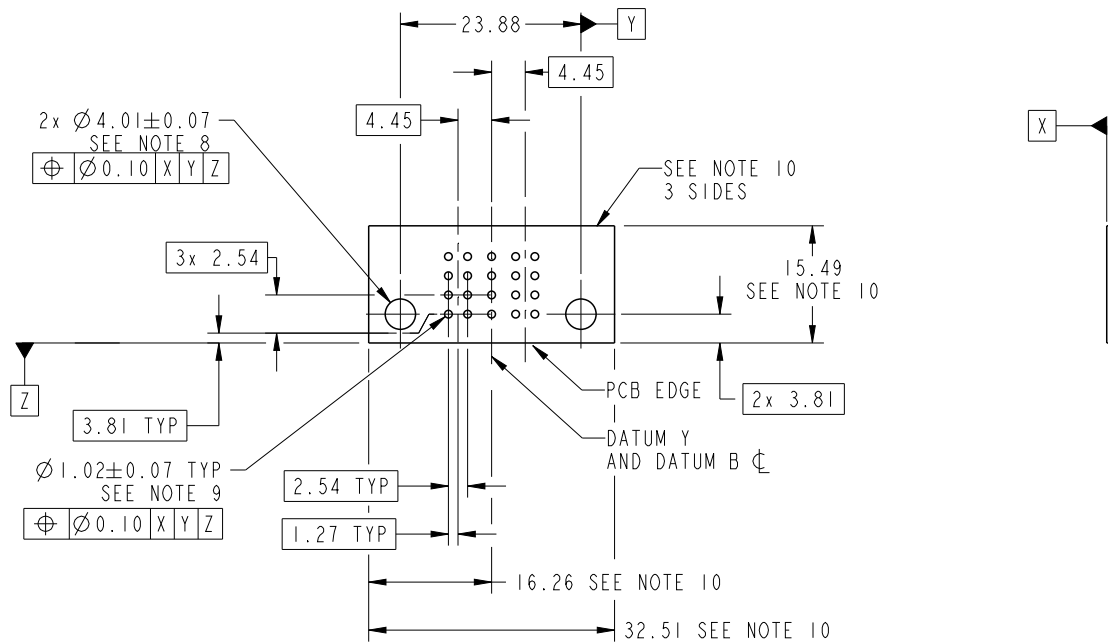

RECOMMENDED PCB LAYOUT

dr	Luo Weller	2013/10/30	projection 	MM 	size	A4	scale	1:1
eng	Luo Weller	2013/11/19			ecn no	-		
chr	-	-			rel level	Released		
appr	Pei-Ming Zheng	2013/11/19	product family	PwrBlade	rel level	Released		
	title	IP+4S+IP R/A PF RECEPTACLE		dwg no	51915-418		rev	A
www.fci.com	cat. no.	Product - Customer Drw			sheet 3 of 4			

PRODUCT NUMBER

51915-418\_\_  
NOTE 3

NOTES:

1. DIMENSIONS AND TOLERANCES ARE IN ACCORDANCE WITH ASME Y14.5M, 1994 UNLESS OTHERWISE SPECIFIED.

CONNECTOR NOTES:

- 2. HOUSING MATERIAL: UL 94 V-0 GLASS FILLED HIGH-TEMP THERMOPLASTIC  
POWER CONTACT MATERIAL: COPPER ALLOY  
SIGNAL PIN MATERIAL: COPPER ALLOY
- 3. SEE ITEM 7 & 8 IN PRINT 10064183 FOR PLATING SPEC OF 51915-418 AND 51915-418LF RESPECTIVELY.

4. MANUFACTURER'S NAME, DATE CODE AND OPTIONAL P/N TO APPEAR ON THIS SURFACE. THE MARK CAN BE OMITTED IF THERE IS NOT ENOUGH SPACE ON THIS SURFACE.

5. PRODUCT SPECIFICATION GS-12-149.  
APPLICATION SPECIFICATION BUS-20-067.

6. PACKAGED IN TRAYS.

PCB NOTES:

7. ALL HOLE DIAMETERS ARE FINISHED HOLE SIZE.

8. MOUNTING HOLES, WHERE APPLICABLE, ARE UNPLATED.

9.  $\varnothing 1.151 \pm 0.025$  DRILLED HOLES PLATED WITH  
0.008 MIN SnPb OR Sn OVER 0.03  
TO 0.08 Cu PLATING TO ACHIEVE  
 $\varnothing 1.02 \pm .07$  HOLE.

10. CONNECTOR KEEP-OUT ZONE.

11. THE VOID CORING IN BETWEEN POWER MODULES, SIGNAL MODULES AND END MODULES ARE OPTIONAL AND THE SHAPE MAY BE DIFFERENT FOR OPTIMIZE THE MOLDING PROCESS. THE VOID CORING WILL NOT EFFECT TO PRODUCT FUNCTION.

dr	Luo Weller	2013/10/30	projection 	MM 	size	A4	scale	1:1	
eng	Luo Weller	2013/11/19			ecn no	-			
chr	-	-							
appr	Pei-Ming Zheng	2013/11/19	product family	PwrBlade	rel level	Released			
	title	IP+4S+IP R/A PF RECEPTACLE			dwg no	51915-418		rev	A
www.fci.com	cat. no.	Product - Customer Drw			sheet 4 of 4				



Copyright FCI.