

THIS DRAWING IS UNPUBLISHED. RELEASED FOR PUBLICATION
 © COPYRIGHT - By - ALL RIGHTS RESERVED.

LOC	DIST	REVISIONS					
		P	LTR	DESCRIPTION	DATE	DWN	APVD
-	-	A		REV PER ECO-12-020950	11DEC12	PY	DW

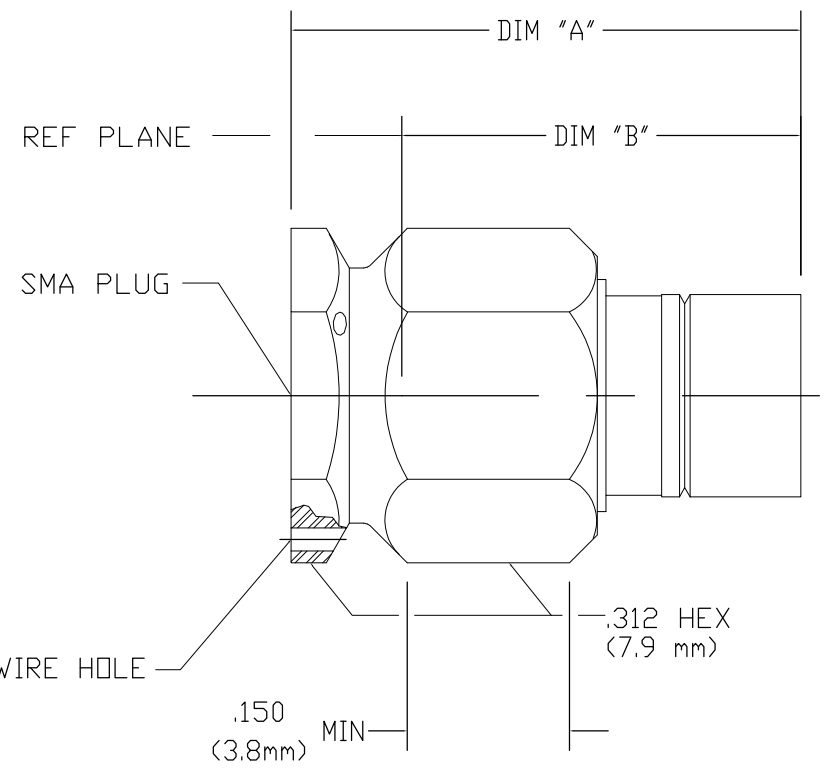

.016 DIA MIN LOCKWIRE HOLE (0.4mm) 3 PLACES EQUALLY SPACED

NOTES:

- DESIGNED FOR USE WITH .141 DIA (RG 402/U) SEMI-RIGID CABLE
- CAPTURED CENTER CONTACT
- PICTORIAL VIEW IS AFTER CRIMPING
- MIN STRAIGHT CABLE LENGTH: .287
- IT IS SUGGESTED TO BEND CABLE PRIOR TO CRIMPING
- CRIMP BUSHING MAY BE PACKAGED UNASSEMBLED. ORIENT GROOVE AS SHOWN.

BEFORE CRIMPING	.664 REF (16.9 mm)	.550 REF (14.0 mm)
AFTER CRIMPING	.568 MAX (14.4 mm)	.441 REF (11.2 mm)
	DIM "A"	DIM "B"

COMPONENT	MATERIAL	FINISH
HOUSING COUPLING NUT BUSHING	STAINLESS STEEL PER ASTM-A484 AND ASTM-A582, TYPE 303	PASSIVATE PER ASTM-A380
DIELECTRIC	TFE FLUOROCARBON PER MIL-P-19468 AND FED SPEC L-P-403	N/A
CENTER CONTACT	BERYLLIUM COPPER PER QQ-C-530,ALLOY 173	GOLD PLATE PER MIL-G-45204 OVER COPPER PLATE PER MIL-C-14550
RETAINING RING	BERYLLIUM COPPER PER QQ-C-533	N/A
GASKET	SILICONE RUBBER PER ZZ-R-765	N/A

CABLE ENTRY DIAMETER MINIMUM	
HOUSING	.143
CONTACT	.037

THIS DRAWING IS A CONTROLLED DOCUMENT.

DIMENSIONS: INCHES

TOLERANCES UNLESS OTHERWISE SPECIFIED:

0 PLC	± -
1 PLC	± -
2 PLC	± -
3 PLC	± -
4 PLC	± -
ANGLES	± -
FINISH	SEE TABLE
MATERIAL	SEE TABLE

DWN O. YEAGER 10DEC2012	 TE Connectivity	NAME SMA STRAIGHT CABLE PLUG SOLDERLESS COMPRESSION CRIMP ATTACHMENT M39012-79B3004	RESTRICTED TO	
CHK D. WILSON 11DEC12				
APVD D. WILSON 11DEC12				
PRODUCT SPEC				
APPLICATION SPEC	SIZE	CAGE CODE	DRAWING NO	RESTRICTED TO
WEIGHT -	A3	00779	C-1050792	-
CUSTOMER DRAWING	SCALE 1:1	SHEET 1 OF 1	REV A	