

1A Low Dropout Positive Linear Regulator

FEATURES

- Output Current of 1A
- Accurate Output Voltage
- Low Quiescent Current
- Low Dropout Voltage of 1.1V at Full Load
- 0.2% Line and 0.3% Load Regulation
- Adjustable Output Down to 1.2V
- Overcurrent and Thermal Protection
- Output Accuracy
 - SPX2810A = 1% Room Temp.
 - SPX2810 = 2% Room Temp.
- Fixed Output Voltage: 1.5V, 2.5V, 3.0V, 3.3V and 5V (SOT223 only)
- Available Packages: SOT-223, TO-252, TO-220, and TO-263

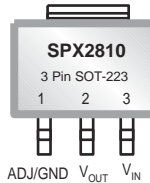

Now Available in Lead Free Packaging

APPLICATIONS

- SCSI-II Active Terminator
- Pocket PC/PDAs
- Notebook Computers
- Battery Chargers
- Disk Drives
- Portable Consumer Equipment
- Portable Instrumentation
- SMPS Post-Regulator

DESCRIPTION

The SPX2810 is a low power positive-voltage regulator designed to satisfy moderate power requirements with a cost effective, small footprint solution. This device is an excellent choice for use in battery-powered applications and portable computers. The SPX2810 has a very low quiescent current and a low dropout voltage of 1.1V at full load. As output current decreases, quiescent current flows into the load, increasing efficiency. SPX2810 is available in adjustable or fixed 1.5, 2.5V, 3.0V, 3.3V and 5.0V output voltages.

The SPX2810 is offered in several industry standard 3-pin surface mount packages: SOT-223, TO-252, TO-220 and TO-263. An output capacitor of 10 μ F or larger, provides unconditionally stability for most applications.

TYPICAL APPLICATION CIRCUITS

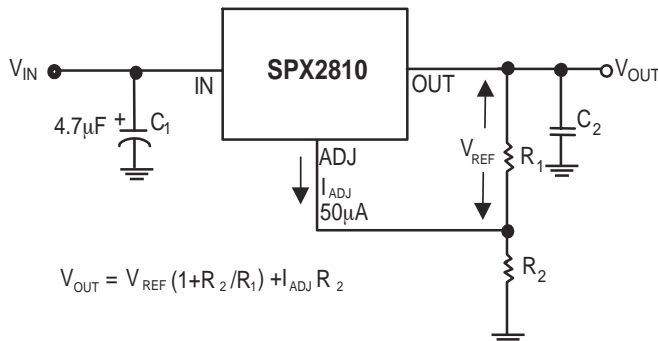

ABSOLUTE MAXIMUM RATINGS

Lead Temperature (soldering, 5 seconds) 300°C
 Storage Temperature Range -65°C to +150°C
 Operating Junction Temperature Range -40°C to +125°C
 Input Supply Voltage +10V

ELECTRICAL CHARACTERISTICS

$V_{IN} = V_{OUT} + 1.5V$, $C_{OUT} = 10\mu F$, at $I_{OUT} = 10mA$, $T_A = 25^\circ C$, unless otherwise specified. Limits in **Boldface** applies over the full operating temperature range.

PARAMETER	CONDITIONS	SPX2810A			SPX2810			UNITS
		MIN	TYP	MAX	MIN	TYP	MAX	
1.5V Version								
Output Voltage	$0 \leq I_{OUT} = 1A$, $3.3V \leq V_{IN} \leq 10V$	1.485 1.470	1.5	1.515 1.530	1.470 1.455	1.5	1.530 1.545	V
2.5V Version								
Output Voltage	$0 \leq I_{OUT} = 1A$, $4.0V \leq V_{IN} \leq 10V$	2.475 2.450	2.5	2.525 2.550	2.450 2.425	2.5	2.550 2.575	V
3.0V Version								
Output Voltage	$0 \leq I_{OUT} = 1A$, $4.5V \leq V_{IN} \leq 10V$	2.970 2.940	3.0	3.030 3.060	2.940 2.790	3.0	3.060 3.090	V
3.3V Version								
Output Voltage	$0 \leq I_{OUT} = 1A$, $4.8V \leq V_{IN} \leq 10V$	3.267 3.234	3.3	3.333 3.366	3.234 3.069	3.3	3.366 3.399	V
5.0V Version								
Output Voltage	$0 \leq I_{OUT} = 1A$, $6.5V \leq V_{IN} \leq 12V$	4.950 4.900	5.0	5.050 5.100	4.900 4.650	5.0	5.100 5.150	V
All Output Options								
Reference Voltage	$I_{OUT} = 10mA$, $V_{IN} = V_{OUT} + 3V$ $10 \leq I_{OUT} \leq 1A$, $1.5V \leq (V_{IN} - V_{OUT}) \leq 5.75V$	1.238 1.225	1.250	1.263 1.281	1.225 1.212	1.250	1.275 1.288	V
Min Load Current	$1.5 \leq (V_{IN} - V_{OUT}) \leq 5.75V$		5	10		5	10	mA
Line Regulation	$2.75 \leq V_{IN} \leq 7V$, $I_{OUT} = T_j = 25^\circ C$ (Note 2)		0.005	0.2		0.005	0.2	%
Load Regulation	$(V_{IN} - V_{OUT}) = 3.0V$, $10mA \leq I_{OUT} \leq 1A$, $T_j = 25^\circ C$ (Note 2)		0.05	0.3		0.05	0.2	%
Dropout Voltage (Note 1)	$I_{OUT} = 1A$		1.1	1.2		1.1	1.2	V
Current Limit	$V_{IN} = 7V$, $1.4 \leq (V_{IN} - V_{OUT})$	1.2	2.0		1.2	2.0		A
Long Term Stability	$T_A = 25^\circ C$, 1000Hrs		0.3	1.0		0.3	1.0	%
Thermal Regulation	$25^\circ C$, 20mS Pulse		0.01	0.02		0.01	0.02	%/Ω
RMS Output Noise	$T_A = 25^\circ C$, $10Hz \leq f \leq 10kHz$		0.003			0.003		%
Thermal Resistance	TO-220 Junction to Tab			3.0			3.0	°C/W
	TO-220 Junction to Ambient			60			60	°C/W
	TO-220 Junction to Tab			3.0			3.0	°C/W
	TO-220 Junction to Ambient			60			60	°C/W
	TO-220 Junction to Tab			6			6	°C/W
	TO-220 Junction to Ambient			126			126	°C/W
	SOT-223 Junction Tab			15			15	°C/W
	TO-220 Junction to Ambient			156			156	°C/W

NOTES:

Note 1: Dropout voltage is defined as the input to output differential at which the output voltage drops 100mV below its nominal value measured at 1V differential at very low values of programmed output voltage, the minimum input supply voltage of 2V (2.3V over temperature) must be taken into account.

Note 2: Thermal regulation is defined as the change in output voltage at a time T after a change in power dissipation is applied excluding load or line regulation effect.

TYPICAL PERFORMANCE CHARACTERISTICS

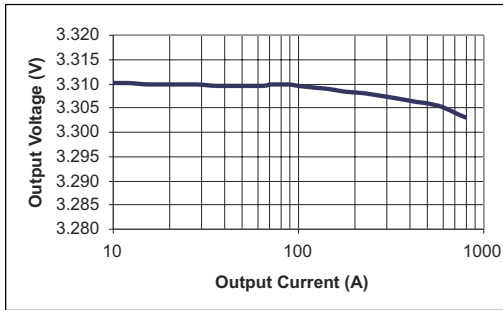

Figure 1. Load Regulation for SPX2810M3-3.3;
 $V_{IN}=4.8V$, $C_{OUT}=2.2\mu F$

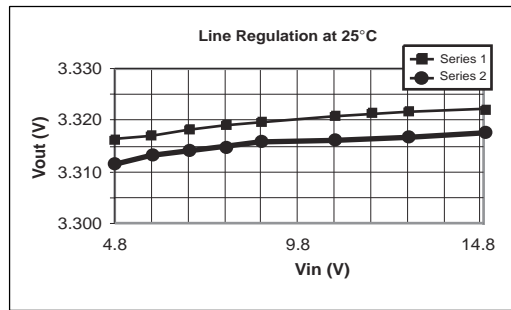

Figure 2. Line Regulation for SPX2810M3-3.3;
 $V_{IN}=4.8V$, $C_{OUT}=2.2\mu F$

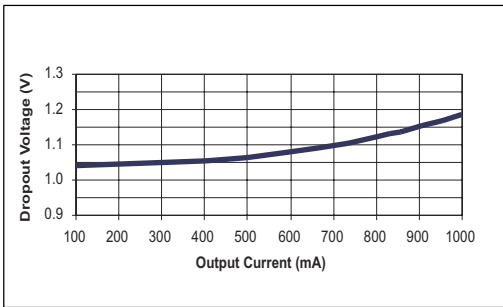

Figure 3. Dropout Voltage vs Output Current for SPX2810M3-3.3; $V_{IN}=4.89V$, $C_{OUT}=10\mu F$

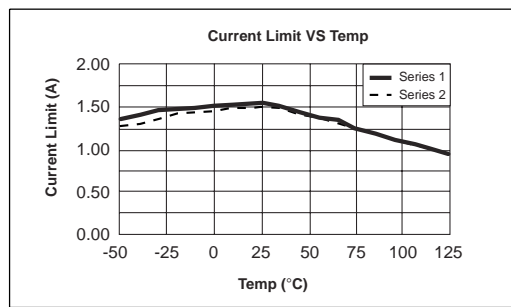

Figure 4. Current Limit for SP1202M3-3.3; $V_{IN}=4.8V$,
 $C_{IN}=C_{OUT}=1.0\mu F$, I_{OUT} pulsed from 10mA to Current Limit

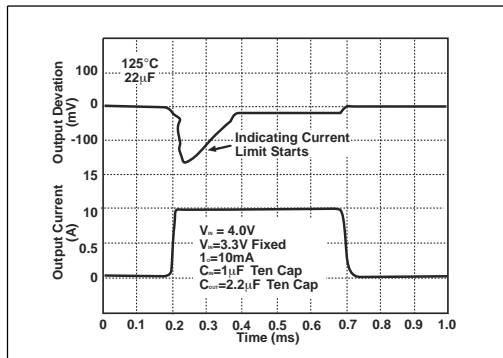

Figure 5. Current Limit for SPX2810M3-3.3, Output Voltage Deviation, (I_{OUT} pulsed from 10mA to 1A).

Output Capacitor

To ensure the stability of the SPX1202, an output capacitor of at least 10µF (tantalum or ceramic) or 50µF (aluminum) is required. The value may change based on the application requirements of the output load or temperature range. The value of ESR can vary based on the type of capacitor used in the applications. The recommended value for ESR is 0.5Ω or less. A larger value of output capacitance (up to 100µF) can improve the load transient response.

SOLDERING METHODS

The SPX2810 SOT-223 package is designed to be compatible with infrared reflow or vapor-phase reflow soldering techniques. During soldering, the non-active or mildly active fluxes may be used. The SPX2810 die is attached to the heatsink lead which exits opposite the input, output, and ground pins.

Hand soldering and wave soldering should be avoided since these methods can cause damage to the device with excessive thermal gradients on the package. The SOT-223 recommended soldering method are as follows: vapor phase reflow and infrared reflow with the component preheated to within 65°C of the soldering temperature range.

THERMAL CHARACTERISTICS

The thermal resistance of SPX2810 depends on type of package and PC board layout as shown in Table 1. The SPX2810 features the internal thermal limiting to protect the device during overload conditions. Special care needs to be taken during continuous load conditions such that the maximum junction temperature does not exceed 125°C. Thermal protection is activated at >144°C and deactivated at <137°C.

Taking the FR-4 printed circuit board and 1/16 thick with 1 ounce copper foil as an experiment, the PCB material is effective at transmitting heat with the tab attached to the pad area and a ground plane layer on the backside of the substrate. Refer to table 1 for the results of the experiment.

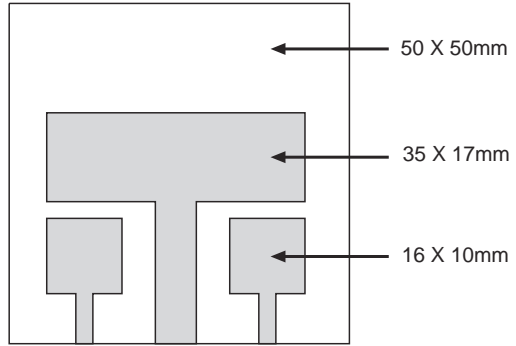

Figure 7. Substrate Layout for SOT-223 for thermal experiment.

The thermal interaction from other components in the application can effect the thermal resistance of the SPX2810. The actual thermal resistance can be determined with experimentation. SPX2810 power dissipation is calculated as follows:

$$P_D = (V_{IN} - V_{OUT})(I_{OUT})$$

Maximum Junction Temperature range:

$$T_J = T_{AMBIENT} (max) + P_D * (Junction\ to\ ambient\ Thermal\ Resistance)$$

Although the SPX2810 offers some limiting circuitry for overload conditions, it is still necessary to insure that maximum junction temperature is not exceeded. Heat will flow through the lowest resistance path, in this case the junction to case. Therefore proper mounting of the regulator to the board is critical. The case of the device is electrically connected to the output. If the case must be electrically isolated, a thermal nonconductive spacer should be used between the case and the board. It thermal resistance must be taken into account.

For example:

$$V_{IN}=10V, V_{OUT}=5V, I_{OUT}=1.5A\ and\ T_A=50°C/W$$

$$\Theta_{JA} = 3°C/W,$$

$$\Theta_{SinkCase} = 6°C/W\ \Theta_{Sink} = 0.5°C/W$$

Power dissipation is calculated as

$$P_D = (V_{IN} - V_{OUT}) * I_{OUT} = 7.5W$$

Junction Temperature will be

$$T_J = T_A + P_D * (\Theta_{Case-Hs} + \Theta_{Hs} + \Theta_{JA})\ or$$

$$T_J = 50 + 7.5(0.5+6+3) = 121.25°C$$

Ripple Rejection

Ripple rejection can be improved by adding a capacitor between the ADJ pin and ground as shown in Figure 6. When ADJ pin bypassing is used, the value of the output capacitor required increases to its maximum. If the ADJ pin is not bypassed, the value of the output capacitor can be lowered to 10(F for an electrolytic aluminum capacitor or 2.2μF for a solid tantalum capacitor (Fig 10). However the value of the ADJ-bypass capacitor should be chosen with respect to the following equation:

$$C = 1 / (6.28 * F_R * R_1)$$

Where C = value of the capacitor in Farads
(select an equal or larger standard value),

F_R = ripple frequency in Hz,
 R_1 = value of resistor R_1 in Ohms

If an ADJ-bypass capacitor is used, the amplitude of the output ripple will be independent of the output voltage. If an ADJ-bypass capacitor is not used, the output ripple will be proportional to the ratio of the output voltage to the reference voltage:

$$M = V_{OUT} / V_{REF}$$

Where M = multiplier for the ripple seen when the ADJ pin is optimally bypassed.

$$V_{REF} = 1.25V$$

PC BOARD AREA mm ²	TOPSIDE COPPER AREA mm ²	BACKSIDE COPPER AREA mm ²	THERMAL RESISTANCE JUNCTION TO AMBIENT °C/W
2500	2500	2500	46
2500	1250	2500	47
2500	950	2500	49
2500	2500	0	51
2500	1800	0	53
1600	600	1600	55
2500	1250	0	58
2500	915	0	59
1600	600	0	67
900	240	900	72
900	240	0	85

TYPICAL APPLICATION CIRCUITS

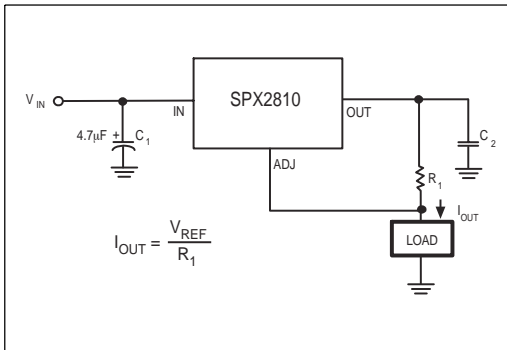

Figure 8. 600mA Current Source

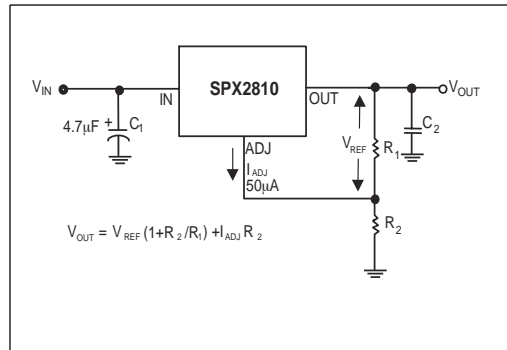

Figure 9. Typical Adjustable Regulator

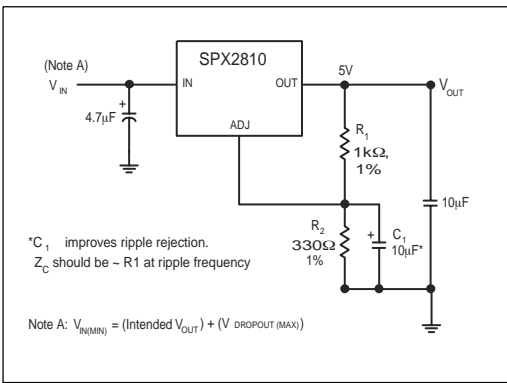

Figure 10. Improving Ripple Rejection

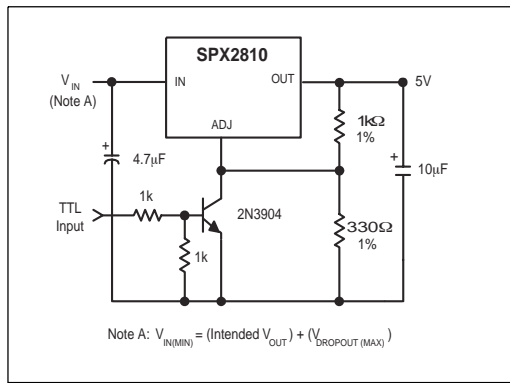

Figure 11. 12.5V Regulator with Shutdown

Output Voltage

The output of the adjustable regulator can be set to any voltage between 1.25V and 10V. The value of V_{OUT} can be quickly approximated using the formula (Figure 9)

$$V_{OUT} = 1.25 * (R1 + R2) / R1.$$

A small correction to this formula is required depending on the values of resistors R1 and R2, since adjustable pin current (approx 50µA) flows through R2. When I_{ADJ} is taken into account, the formula becomes

$$V_{OUT} = V_{REF} * (1 + (R_2 / R_1)) + I_{ADJ} * R_2, \text{ where } V_{REF} = 1.25V.$$

Layout Considerations

Parasitic line resistance can degrade load regulation. In order not to affect the behavior of the regulator, it is best to connect R_1 to the case as illustrated in Figure 11. For the same reason, R_2 should be connected to the negative side of the load.

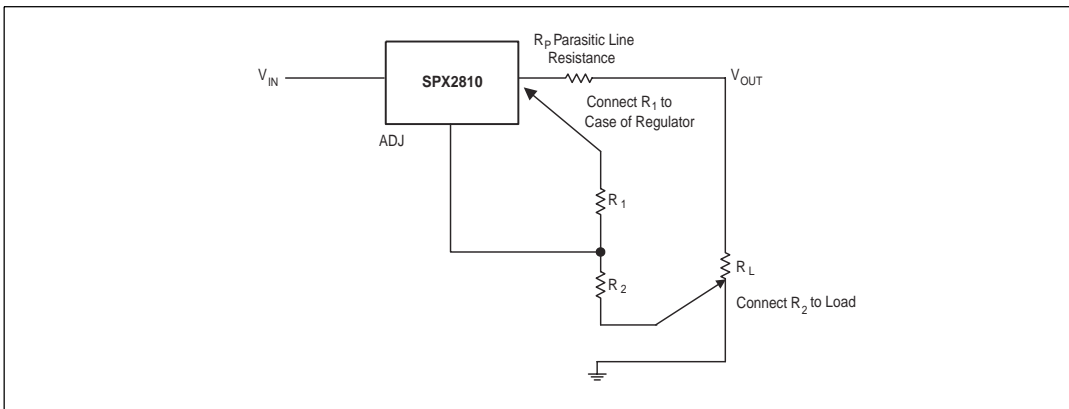
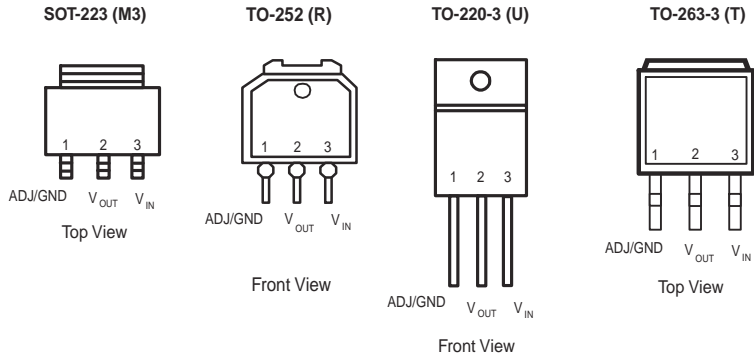
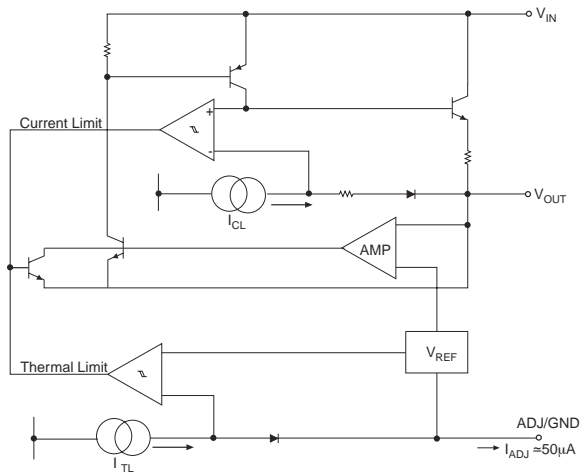

Figure 12. Recommended Connections for Best Results



Note: TAB is connected to V_{OUT} .

BLOCK DIAGRAM



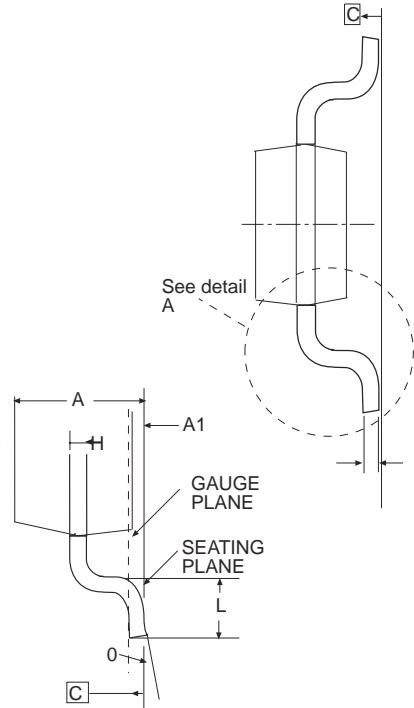
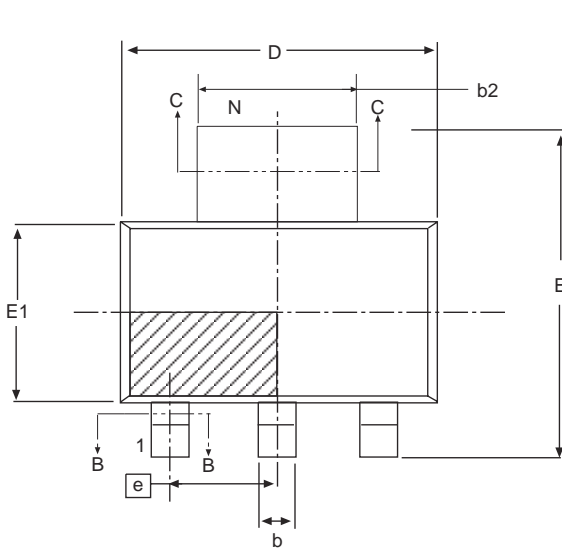

3 PIN SOT-223 JEDEC TO-261 (AA) Variation	Dimensions in (mm)		
	MIN	NOM	MAX
A	-	-	1.80
A1	0.02	-	0.10
A2	1.50	1.60	1.70
b	0.66	0.76	0.84
b2	2.90	3.00	3.10
c	0.23	0.30	0.35
D	6.30	6.50	6.70
E	6.70	7.00	7.30
E1	3.30	3.50	3.70
e	2.30 BASIC		
e1	4.60 BASIC		
L	0.75	-	-
∅	0°	-	10°

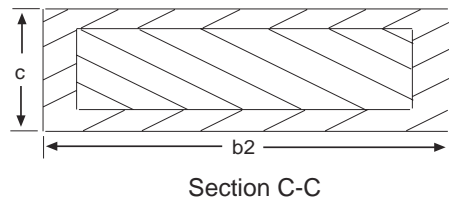
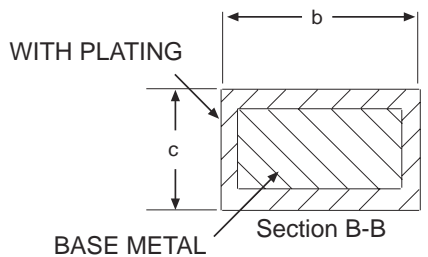

3 PIN SOT-223

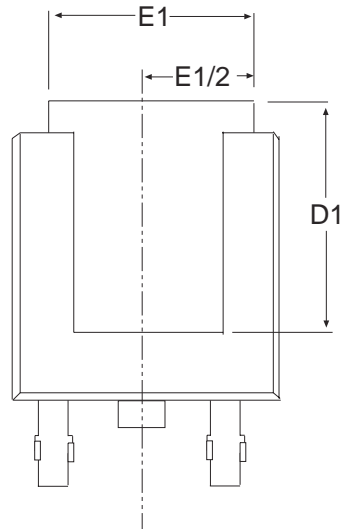
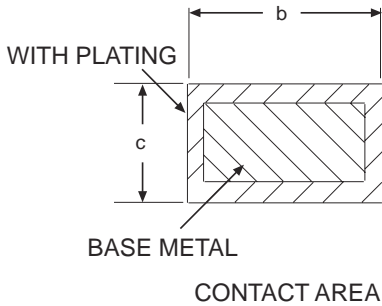
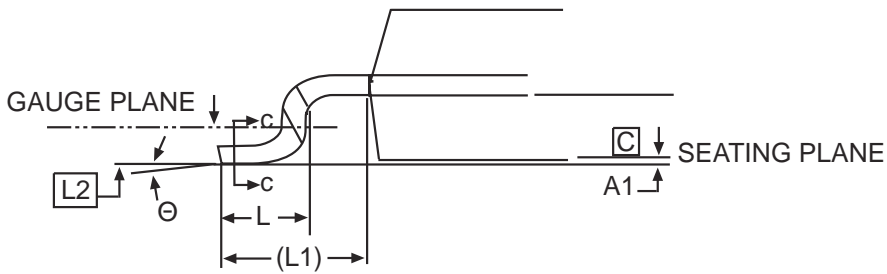

3 PIN TO-252 JEDEC TO-252 (AA) Variation	Dimensions in inches		
	MIN	NOM	MAX
A1	-	-	.005
c	.018	-	.024
D1	.205	-	-
E1	.170	-	-
H	.370	-	.410
L	.055	.060	.070
L1	.108 REF		
L2	.020 BSC		

3 PIN TO-252

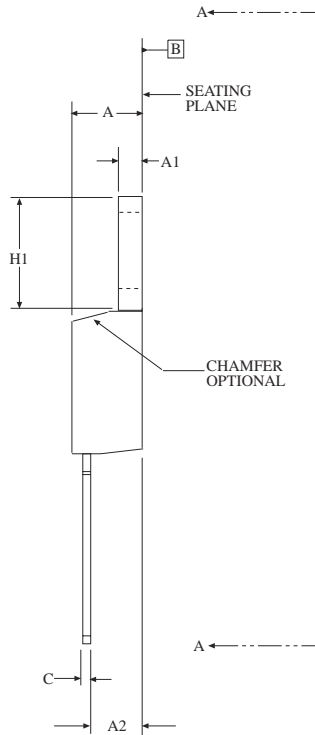
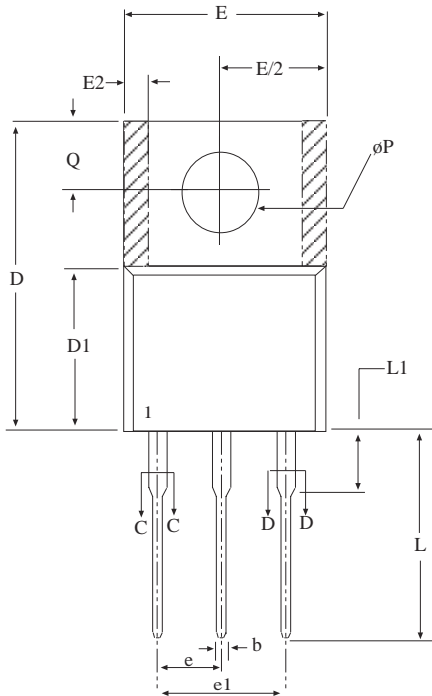

Dimensions in (mm)	3 PIN TO-220 JEDEC TO-220 (AB) Variation		
	MIN	NOM	MAX
A	.140	-	.190
A1	.020	-	.055
A2	.080	-	.115
b	.015	.027	.040
b2	.045	-	.070
c	.014	-	.024
D	.560	-	.650
D1	.330	-	.355
D2	.480	-	.507
E	.380	-	.420
E1	.270	-	.350
E2	-	-	.030
e	.100 BSC		
e1	.200 BSC		
H1	.230	-	.270
L1	-	-	.250
L2	-	-	-
ΔP	.139	-	.161
Q	.100	-	.135

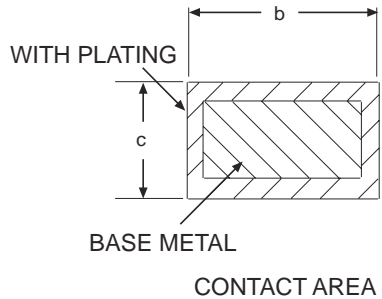

3 PIN TO-220

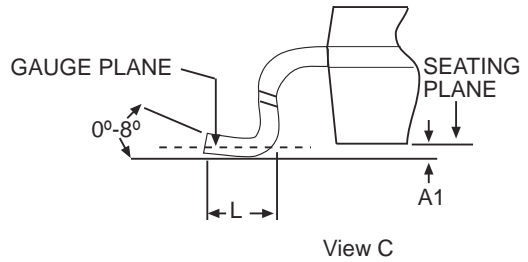
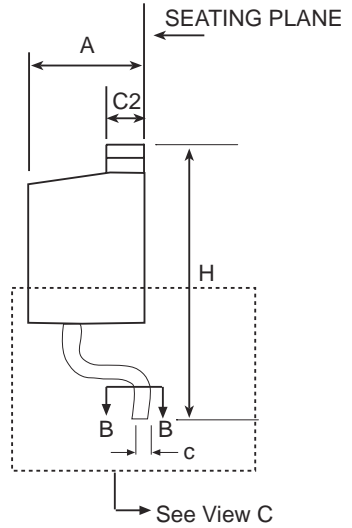
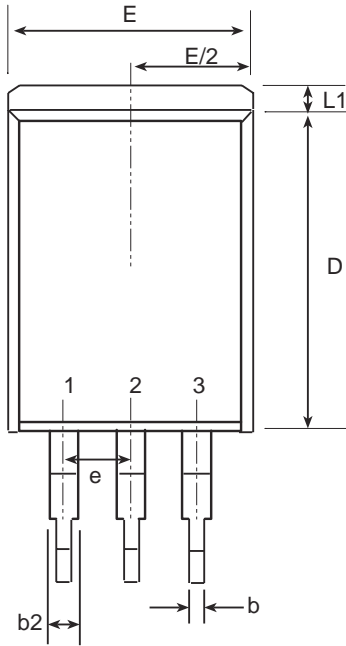

3-PIN TO-263 JEDEC TO-263 (AA) Variation	Dimensions in inches		
	MIN	NOM	MAX
A	.160	-	.190
A1	.000	-	.010
b	.020	-	.039
c	.015	-	.029
D	.330	-	.380
D1	.270	-	-
E	.380	-	.420
E1	.245	-	-
e	.100 BSC		
H	.575	-	.625
L	.070	-	.110
L1	-	-	.066
L2	-	-	.070
L3	.010 BSC		

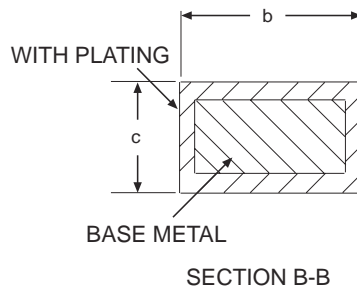

3 PIN TO-263

ORDERING INFORMATION

Part Number	Accuracy	Package Types
SPX2810AM3	1%	3 lead SOT-223
SPX2810AM3/TR	1%	3 lead SOT-223
SPX2810AM3-1.5	1%	3 lead SOT-223
SPX2810AM3-1.5/TR	1%	3 lead SOT-223
SPX2810AM3-2.5	1%	3 lead SOT-223
SPX2810AM3-2.5/TR	1%	3 lead SOT-223
SPX2810AM3-3.0	1%	3 lead SOT-223
SPX2810AM3-3.0/TR	1%	3 lead SOT-223
SPX2810AM3-3.3	1%	3 lead SOT-223
SPX2810AM3-3.3/TR	1%	3 lead SOT-223
SPX2810AR	1%	3 lead TO-252
SPX2810AR/TR	1%	3 lead TO-252
SPX2810AR-1.5	1%	3 lead TO-252
SPX2810AR-1.5/TR	1%	3 lead TO-252
SPX2810AR-2.5	1%	3 lead TO-252
SPX2810AR-2.5/TR	1%	3 lead TO-252
SPX2810AR-3.0	1%	3 lead TO-252
SPX2810AR-3.0/TR	1%	3 lead TO-252
SPX2810AR-3.3	1%	3 lead TO-252
SPX2810AR-3.3/TR	1%	3 lead TO-252
SPX2810AT	1%	3 Lead TO-263
SPX2810AT/TR	1%	3 Lead TO-263
SPX2810AT-1.5	1%	3 Lead TO-263
SPX2810AT-1.5/TR	1%	3 Lead TO-263
SPX2810AT-2.5	1%	3 Lead TO-263
SPX2810AT-2.5/TR	1%	3 Lead TO-263
SPX2810AT-3.0	1%	3 Lead TO-263
SPX2810AT-3.0/TR	1%	3 Lead TO-263
SPX2810AT-3.3	1%	3 Lead TO-263
SPX2810AT-3.3/TR	1%	3 Lead TO-263
SPX2810AU	1%	3 lead TO220
SPX2810AU-1.5	1%	3 lead TO220
SPX2810AU-2.5	1%	3 lead TO220
SPX2810AU-3.0	1%	3 lead TO220
SPX2810AU-3.3	1%	3 lead TO220

Available in lead free packaging. To order add "-L" suffix to part number.

Example: SPX2810AM-3.3/TR = standard; SPX2810AM-L-3.3/TR = lead free

/TR = Tape and Reel

Pack quantity is 500 for TO-263, 2000 for TO-252 and 2500 for SOT-223.

[CLICK HERE TO ORDER SAMPLES](#)

Part Number	Accuracy	Package Types
SPX2810M3	2%	3 lead SOT-223
SPX2810M3/TR	2%	3 lead SOT-223
SPX2810M3-1.5	2%	3 lead SOT-223
SPX2810M3-1.5/TR	2%	3 lead SOT-223
SPX2810M3-2.5	2%	3 lead SOT-223
SPX2810M3-2.5/TR	2%	3 lead SOT-223
SPX2810M3-3.0	2%	3 lead SOT-223
SPX2810M3-3.0/TR	2%	3 lead SOT-223
SPX2810M3-3.3	2%	3 lead SOT-223
SPX2810M3-3.3/TR	2%	3 lead SOT-223
SPX2810M3-5.0	2%	3 lead SOT-223
SPX2810M3-5.0/TR	2%	3 lead SOT-223
SPX2810R	2%	3 lead TO-252
SPX2810R/TR	2%	3 lead TO-252
SPX2810R-1.5	2%	3 lead TO-252
SPX2810R-1.5/TR	2%	3 lead TO-252
SPX2810R-2.5	2%	3 lead TO-252
SPX2810R-2.5/TR	2%	3 lead TO-252
SPX2810R-3.0	2%	3 lead TO-252
SPX2810R-3.0/TR	2%	3 lead TO-252
SPX2810R-3.3	2%	3 lead TO-252
SPX2810R-3.3/TR	2%	3 lead TO-252
SPX2810T	2%	3 Lead TO-263
SPX2810T/TR	2%	3 Lead TO-263
SPX2810T-1.5	2%	3 Lead TO-263
SPX2810T-1.5/TR	2%	3 Lead TO-263
SPX2810T-2.5	2%	3 Lead TO-263
SPX2810T-2.5/TR	2%	3 Lead TO-263
SPX2810T-3.0	2%	3 Lead TO-263
SPX2810T-3.0/TR	2%	3 Lead TO-263
SPX2810T-3.3	2%	3 Lead TO-263
SPX2810T-3.3/TR	2%	3 Lead TO-263
SPX2810U	2%	3 lead TO220
SPX2810U-1.5	2%	3 lead TO220
SPX2810U-2.5	2%	3 lead TO220
SPX2810U-3.0	2%	3 lead TO220
SPX2810U-3.3	2%	3 lead TO220

Available in lead free packaging. To order add "-L" suffix to part number.

Example: SPX2810M-3.3/TR = standard; SPX2810M-L-3.3/TR = lead free

/TR = Tape and Reel

Pack quantity is 500 for TO-263, 2000 for TO-252 and 2500 for SOT-223.

[CLICK HERE TO ORDER SAMPLES](#)



ANALOG EXCELLENCE

**Headquarters and
Sales Office**
233 South Hillview Drive
Milpitas, CA 95035
TEL: (408) 934-7500
FAX: (408) 935-7600