

PROFIBUS ABSOLUTE MULTI-TURN ENCODER, MHM510-PROF RANGE



- MHM10-PROF, standard encoder Ø58mm with Profibus interface:
- Robust and compact conception
- Solid shaft version Ø 10 mm (Ø6 mm available upon request)
- Precision ball bearings with sealing flange
- High temperatures performances -40°C ... +85°C
- Code disc made of unbreakable and durable plastic
- Mechanical memorisation of the number of turns by gears
- Resolution : 13 bits = 8192 steps/turn (max 16 bits)
- Number of turns : 12 bits = 4096 turns (max 14 bits)
- Polarity inversion and short circuit protection
- Highly integrated circuit in SMD-technology



MHM510-PROF (connection cap included)

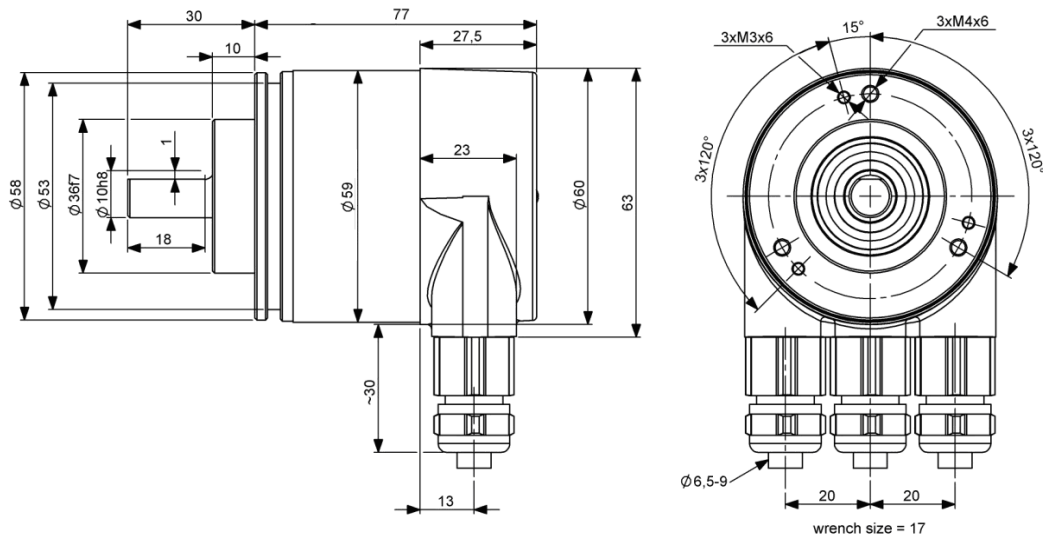

Red LED	Green LED	Status / possible cause
Dark	Dark	No power supply
Bright	Bright	Encoder is ready for operation but it has not received any configuration data after power on. Possible causes: address setting incorrect, Bus lines not connected correctly
Bright	Flashing	Parameter or configuration error. The encoder receives configuration or parameter data with incorrect length or inconsistent data Possible cause: parameter value "total measuring range" too high
Flashing	Bright	The encoder is ready for operation but not addressed by the master (e.g. incorrect address in configuration).
Bright	Dark	Encoder has not received any data for a longer period (about 40 sec.) Possible cause: bus line has been interrupted
Dark	Bright	Normal operation in data exchange mode
Dark	Flashing	Commissioning mode

Led status at the front of the connection cap

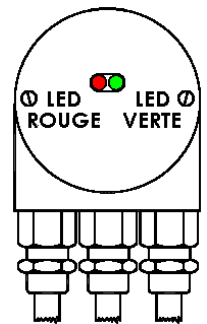

MECHANICAL DATA

Material	Cover : aluminum	Vibrations (EN 60068-2-6)	≤ 10 g (10Hz... 1 000Hz)			
	Body : aluminum		Weight	600 g		
	Shaft: stainless steel		Operating temperature	- 40 ... + 85°C		
Max. shaft loading	Axial : 40 N	Storage temperature	- 40 ... + 85°C			
	Radial : 110 N	Humidity	98 % sans condensation			
Shaft Inertia	≤ 30 g.cm ²	Protection class (EN 60529)	IP65: cover			
Torque	≤ 3 N.cm		IP64: shaft			
RPM (continuous operation))	6 000 rpm	Lifetime in 10 ⁸ revolutions with F _a / F _r (axial/radial)				
Shock (EN 60068-2-27))	≤ 100 g (halfsinus, 6 ms)	40 N / 60 N	40 N / 80 N	40 N / 110 N		
Shock (EN 60028-2-29)	≤ 10 g (half-sinus, 16ms)	25	10	4		

PROFIBUS ABSOLUTE MULTI-TURN ENCODER, MHM510-PROF RANGE



ELECTRICAL DATA

Interface	ISO 11898	Power consumption	max 2,5W
Transmission rate	Max 12 MBauds	Step Frequency LSB	800 kHz
Device addressing	by rotary switches	Accuracy	+ 1/2 LSB
Power supply	10 – 30Vdc	EMC	EN 61000-6-4 EN 61000-6-2
Current consumption	max 100mA (24Vdc)	Electrical lifetime	> 10 ⁵ h

PROGRAMMABLE PARAMETERS

The Profibus-DP interface supports CLASS 1 and CLASS 2 functionality according to the encoder profile . In addition to these functions the GSD-file supports further features, for example software limit switches. Further more, the following encoder parameters can be programmed directly via the Profibus-DP network without any extra device

Counting Direction	This parameter counting direction defines whether the output code increases or decreases when the shaft rotates clockwise.
Resolution (positions per turns)	The parameter 'resolution per revolution' is used to program the desired number of steps per revolution. Each value between 1 and the physical resolution per revolution can be programmed
Total Resolution "Max-RANGE"	This parameter is used to program the desired number of measuring units over the total measuring range. This value may not exceed the total physical resolution of the absolute rotary encoder
Reset (RAX)	The preset value is the desired position value, which should be reached at a certain physical position of the axis. The position value is set to the desired process value by the parameter preset
Velocity	The implemented software can additionally deliver the current velocity. This value is transmitted in binary code, 16 Bit, in addition to the process value It is possible to choose between four different units: steps per 10 ms, per 100 ms, per 1000 ms and revolutions per minute
Software limit switches function	Two software limit switches can be set. If the position value falls below the lower or exceeds the higher limit switch, a status bit in the process value is set
Teach-in (Online parameterization)	A special mode is available for commissioning phase of the device. This makes it possible to change parameters while the encoder is in data exchange mode

INTERFACE

The rotary encoder is connected by two or three cables, depending on whether the power supply is integrated into the bus cable or connected separately. If the power supply is integrated into the bus cable one of the cable glands can be fitted with a plug. The cable glands are suitable for cable diameters from 6.5 up to 9 mm

The Profibus-DP device address is set by user-friendly rotary switches in the connection cap. Allowed addresses are between 1 and 99, each can only be used once. The connection cap can easily be opened for installation by removing the two cap screws

Termination resistors are integrated in the connection cap. These must be switched on if the encoder is connected at the end or the beginning of the bus

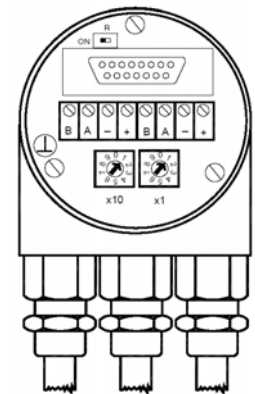

ORDERING REFERENCE Contact the factory for special versions, ex: electronics, special flanges, connections...)

MHM5	DP	C1	B	12	13	C	10	0	H3P
Absolute multi turn encoder	Profibus	Version	Code : Binary	Number of turns 2 ¹² (4 096)	Resolution (pos./turn) 2 ¹³ (8 192)	Clamp Flange	Shaft diameter : 10mm	Without mechanical option	Connection Cap

Note: The "H3P" terminal box version is shorter than the "0CC" one.

Datasheets provided by Sensata Technologies, Inc., its subsidiaries and/or affiliates (“Sensata”) are solely intended to assist third parties (“Buyers”) who are developing systems that incorporate Sensata products (also referred to herein as “components”). Buyer understands and agrees that Buyer remains responsible for using its independent analysis, valuation, and judgment in designing Buyer’s systems and products. Sensata datasheets have been created using standard laboratory conditions and engineering practices. Sensata has not conducted any testing other than that specifically described in the published documentation for a particular datasheet. Sensata may make corrections, enhancements, improvements, and other changes to its datasheets or components without notice.

Buyers are authorized to use Sensata datasheets with the Sensata component(s) identified in each particular datasheet. HOWEVER, NO OTHER LICENSE, EXPRESS OR IMPLIED, BY ESTOPPEL OTHERWISE TO ANY OTHER SENSATA INTELLECTUAL PROPERTY RIGHT, AND NO LICENSE TO ANY THIRD PARTY TECHNOLOGY OR INTELLECTUAL PROPERTY RIGHT, IS GRANTED HEREIN. SENSATA DATASHEETS ARE PROVIDED “AS IS”. SENSATA MAKES NO WARRANTIES OR REPRESENTATIONS WITH REGARD TO THE DATASHEETS OR USE OF THE DATASHEETS, EXPRESS, IMPLIED, OR STATUTORY, INCLUDING ACCURACY OR COMPLETENESS. SENSATA DISCLAIMS ANY WARRANTY OF TITLE AND ANY IMPLIED WARRANTIES OF MERCHANTABILITY, FITNESS FOR A PARTICULAR PURPOSE, QUIET ENJOYMENT, QUIET POSSESSION, AND NON-INFRINGEMENT OF ANY THIRD PARTY INTELLECTUAL PROPERTY RIGHTS WITH REGARD TO SENSATA DATASHEETS OR USE THEREOF.

All products are sold subject to Sensata’s terms and conditions of sale supplied at www.sensata.com. SENSATA ASSUMES NO LIABILITY FOR APPLICATIONS ASSISTANCE OR THE DESIGN OF BUYERS’ PRODUCTS. BUYER ACKNOWLEDGES AND AGREES THAT IT IS SOLELY RESPONSIBLE FOR COMPLIANCE WITH ALL LEGAL, REGULATORY, AND SAFETY-ELATED REQUIREMENTS CONCERNING ITS PRODUCTS, AND ANY USE OF SENSATA COMPONENTS IN ITS APPLICATIONS, NOTWITHSTANDING ANY APPLICATIONS-RELATED INFORMATION OR SUPPORT THAT MAY BE PROVIDED BY SENSATA.

Mailing Address: Sensata Technologies, Inc., 529 Pleasant Street, Attleboro, MA 02703, USA

CONTACT US

Regional head offices:

United States of America

Sensata Technologies

Attleboro, MA

Phone: 508-236-3800

E-mail: support@sensata.com

Netherlands

Sensata Technologies Holland B.V.

Hengelo

Phone: +31 74 357 8000

E-mail: support@sensata.com

China

Sensata Technologies China Co., Ltd.

Shanghai

Phone: +8621 2306 1500

E-mail: support@sensata.com

Copyright © 2023 Sensata Technologies, Inc.