

# **QT-Brightek PLCC Series**

## **Dome Type PLCC2 LED**

**Part No.: QBLP670D-IW-CW**

Product: QBLP670D-IW-CW	Date: April 06, 2021	Page 1 of 11
	Version# 1.2	

---

**Table of Contents:**

Introduction .....	3
Electrical / Optical Characteristic (Ta=25 °C) .....	4
Absolute Maximum Rating .....	4
CIE Chromaticity Diagram.....	5
Characteristic Curves.....	6
Solder Profile & Footprint.....	7
Recommended Handling Precautions.....	8
Packing .....	9
Labeling .....	10
Ordering Information .....	10
Revision History .....	11
Disclaimer .....	11

## Introduction

### Feature:

- Clear lens
- Ultra bright dome type PLCC2 LED
- InGaN technology
- Viewing angle: 30deg typ.

### Description:

This dome type PLCC2 LED has a height profile of 3.6mm. Combination of high brightness output and robust package, this LED is ideal for architecture lighting, status indication, and color mixing applications.

### Application:

- Status indication
- Industrial equipment backlighting
- Architecture lighting

### Certification & Compliance:

- TS16949
- ISO9001
- RoHS Compliant



### Dimension:

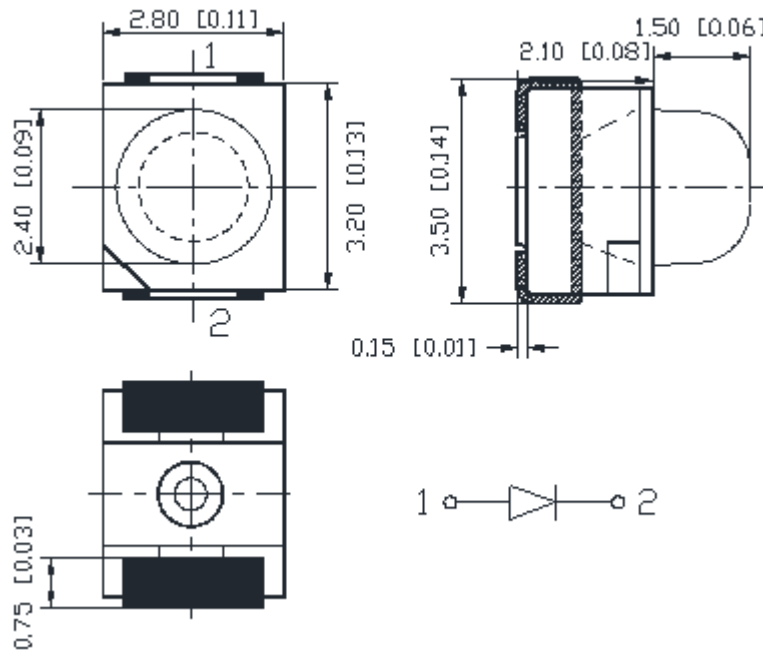

Units: mm / tolerance = +/-0.2mm

### Electrical / Optical Characteristic (Ta=25 °C)

Product	Color	IF (mA)	VF (V)		CIE Coordinates	Iv (mcd)	
			Typ.	Max.	Typ.	Min.	Typ.
QBLP670D-IW-CW	Cool White	20	3.1	3.7	X=0.29, Y=0.29	1600	2600
					CCT: 9000K		

### Absolute Maximum Rating

Material	P <sub>d</sub> (mW)	I <sub>F</sub> (mA)	I <sub>FP</sub> (mA)*	V <sub>R</sub> (V)	T <sub>OP</sub> (°C)	T <sub>ST</sub> (°C)
InGaN	111	30	125	5	-40 ~+80	-40 ~+85

\*Duty 1/8 @ 1KHz

### Forward Voltage V<sub>F</sub> for InGaN @ I<sub>F</sub>=20mA

Bin	Min.	Max.	Unit
f	2.8	3.1	V
g	3.1	3.4	
h	3.4	3.7	

### Luminous Intensity I<sub>v</sub> @ I<sub>F</sub>=20mA

Bin	Min.	Max.	Unit
V	1600	2000	mcd
W	2000	2500	
X	2500	3200	
Y	3200	4000	
Z	4000	5200	

**CIE Chromaticity Diagram**

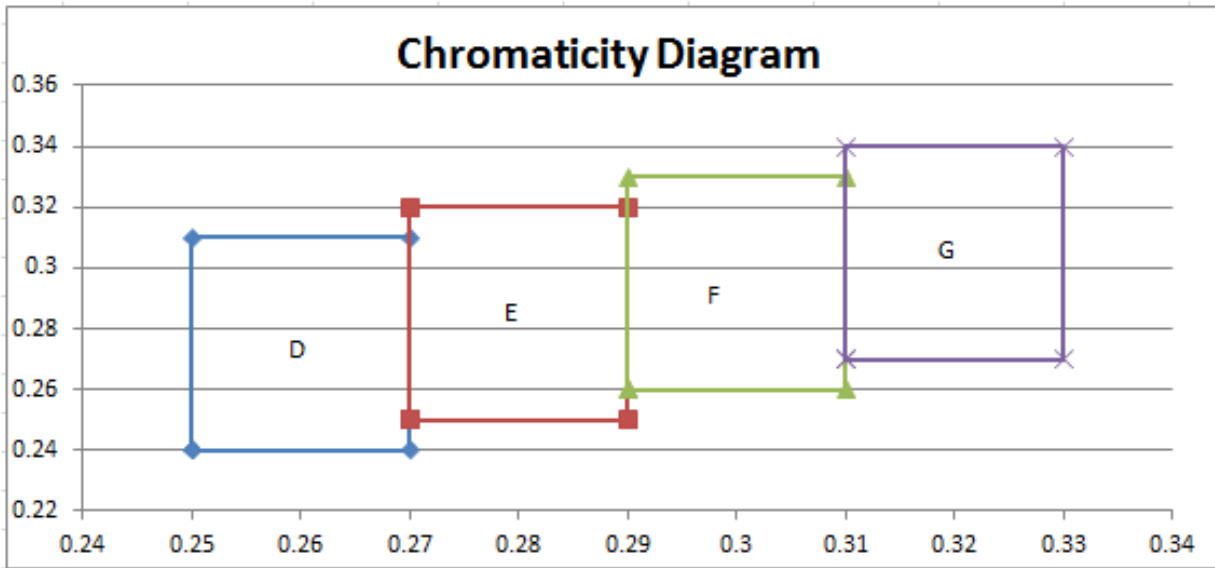

Rank	Chromaticity coordinates				
		X	Y	X	Y
D	X	0.25	0.31	0.27	0.27
	Y	0.24	0.24	0.31	0.24
E	X	0.27	0.32	0.29	0.29
	Y	0.25	0.25	0.32	0.25
F	X	0.29	0.33	0.31	0.31
	Y	0.26	0.26	0.33	0.26
G	X	0.31	0.34	0.33	0.33
	Y	0.27	0.27	0.34	0.27

**Characteristic Curves**

InGaN

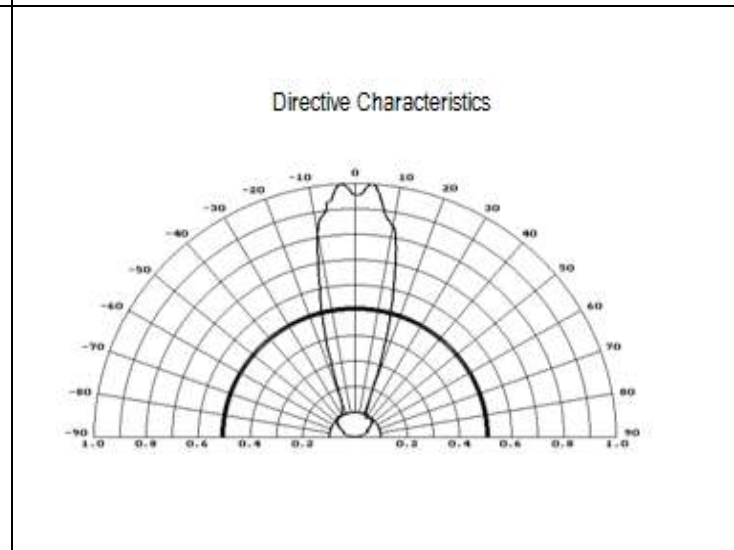
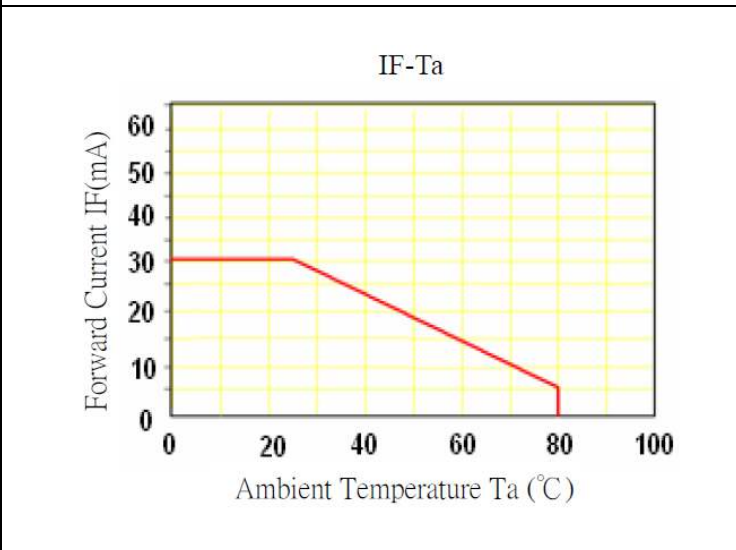
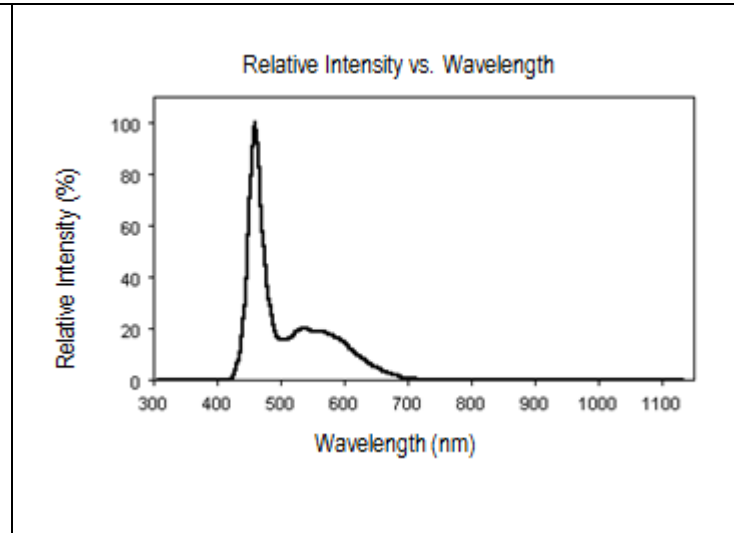
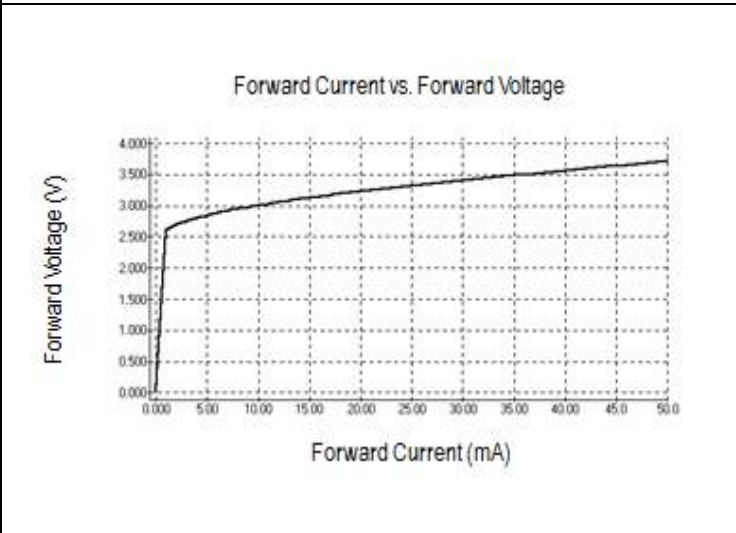

**Solder Profile & Footprint**

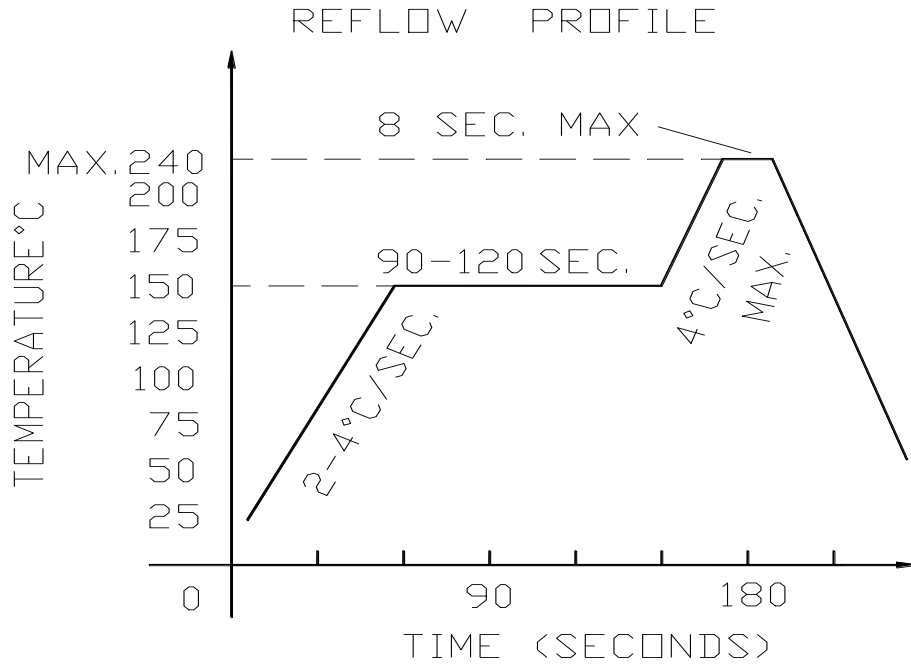

**Recommended Pad Layout**

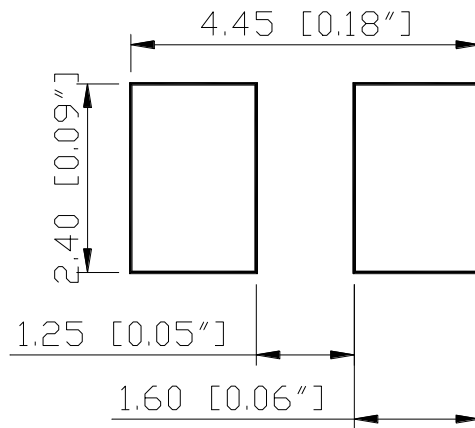

Units: mm

Tolerance: ±0.2mm

---

## Recommended Handling Precautions

1. It is recommended to store the products in sealed and anti-static bags with desiccant inside at the following condition:
  - Humidity: <60% RH
  - Temperature: 5°C~30°C
2. Shelf life in sealed bag: 12 month at 5°C~30°C and < 60% R.H
3. After the package is opened:
  - 3.1 The products should be used within a week (168 hours)
  - 3.2 Or product should be stored at  $\leq 20\%$  RH and (5°C~30°C) with zip-lock sealed bag
  - 3.3 It is recommended to bake before soldering when the package is unsealed after 72hrs;
    - 3.3.1 Baking condition (Tape and Reel Type): 60±3°C (24~36 hrs) and < 5% RH
  - 3.4 Products require baking before soldering/mounting if **3.1** or **3.2** is not met. Baking condition refers to **3.3.1**
4. If the product is not used within 3 months since manufacturing date, it is recommended to bake for 24 hrs @ 60°C before use.
5. If the product is not used after 3 months since manufacturing date, it is recommended to bake for 36~48 hrs @ 60°C before use.

Product: QBLP670D-IW-CW	Date: April 06, 2021	Page 8 of 11
	Version# 1.2	



## Packing

### Reel Dimension:

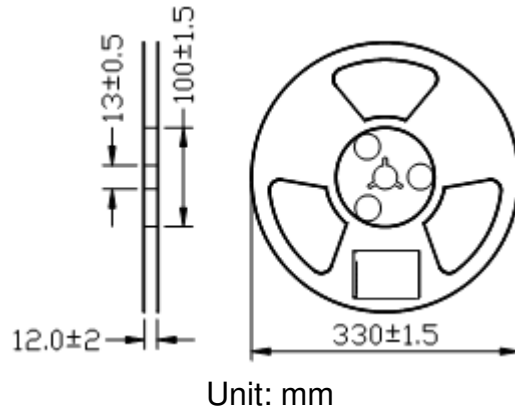

### Tape Dimension:

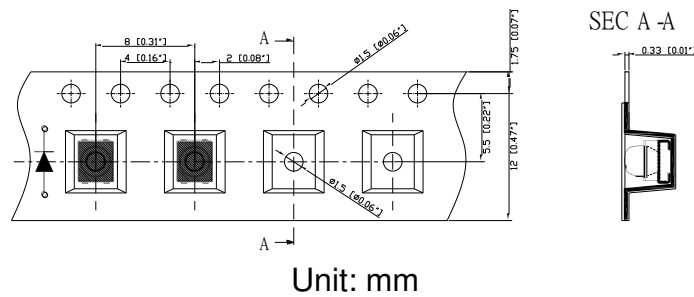

### Arrangement of Tape:

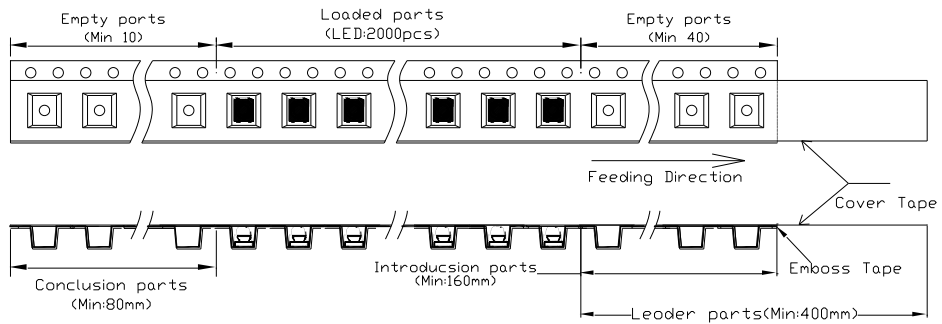

### Packaging Specifications:

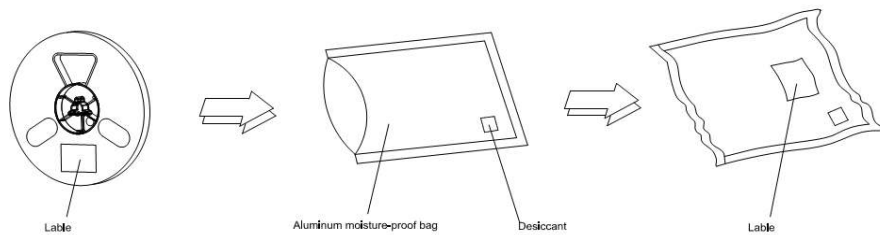

**Labeling**

Part No: \_\_\_\_\_

Customer P/N: \_\_\_\_\_

Item: \_\_\_\_\_

Q'ty: \_\_\_\_\_

Vf: \_\_\_\_\_

Iv: \_\_\_\_\_

Wl: \_\_\_\_\_

Date: \_\_\_\_\_

**Made in China****Ordering Information**

Part #	Orderable Part #	Spec Range	Quantity per Reel
QBLP670D-IW-CW	QBLP670D-IW-CW	Iv=2600mcd typ. @ If=20mA / CCT Coordinate: (0.29, 0.29) typ.	2,000 units

---

## Revision History

Description:	Revision #	Revision Date
New Release of QBLP670D-IW-CW	V1.0	04/01/2014
Update luminous intensity bin	V1.1	11/12/2015
Update logo and format	V1.2	04/06/2021

## Disclaimer

QT-BRIGHTTEK reserves the right to make changes without further notice to any products herein to improve reliability, function or design. QT-BRIGHTTEK does not assume any liability arising out of the application or use of any product or circuit described herein; neither does it convey any license under its patent rights, nor the rights of others.

## Life Support Policy

QT-BRIGHTTEK's products are not authorized for use as critical components in life support devices or systems without the express written approval of QT-BRIGHTTEK. As used herein:

1. Life support devices or systems are devices or systems which, (a) are intended for surgical implant into the body, or (b) support or sustain life, and (c) whose failure to perform when properly used in accordance with instructions for use provided in the labeling, can be reasonably expected to result in a significant injury of the user.
2. A critical component in any component of a life support device or system whose failure to perform can be reasonably expected to cause the failure of the life support device or system, or to affect its safety or effectiveness.