

PRODUCT NO.
10119313-*

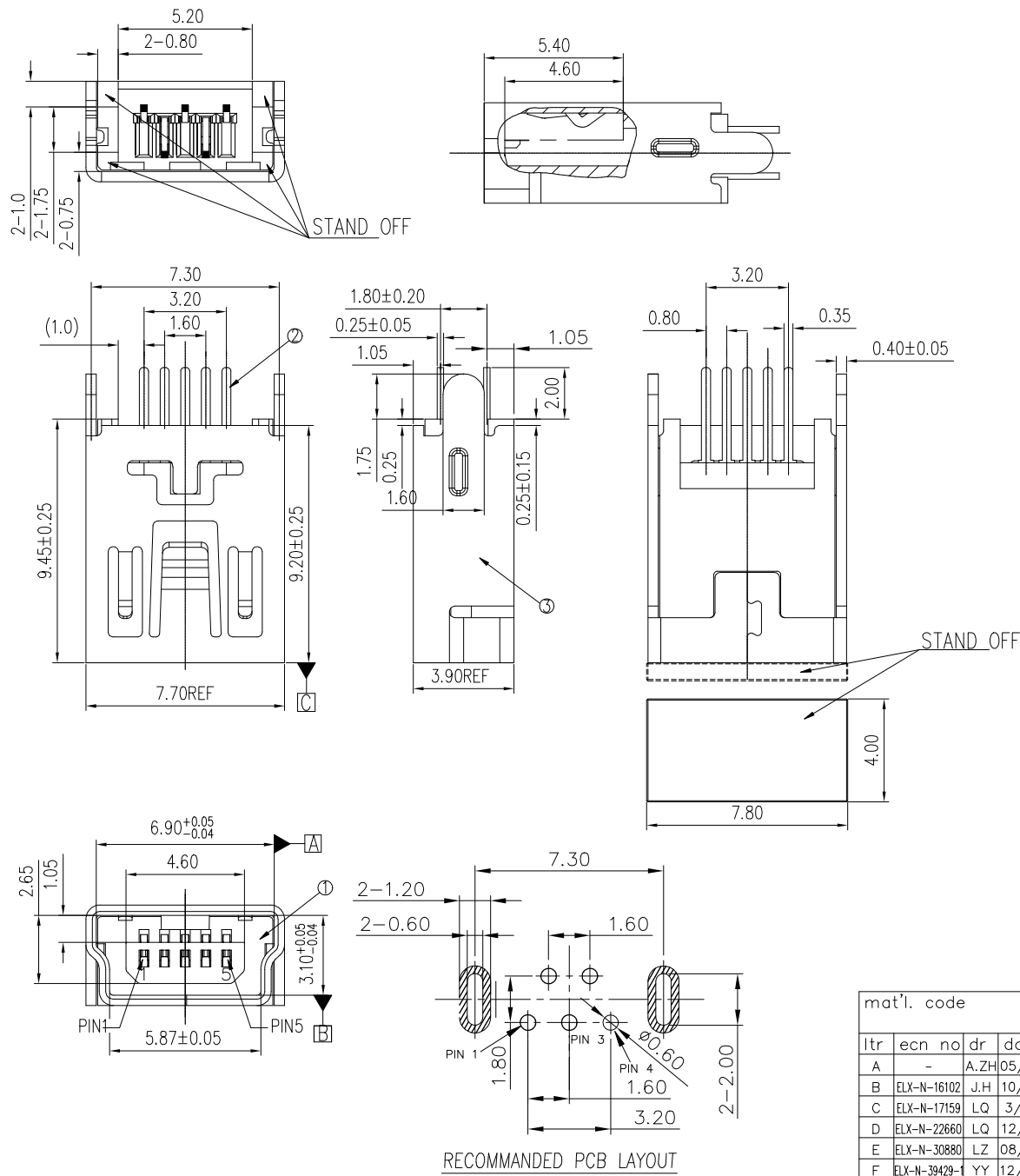

NOTES:

- MATERIAL:
HOUSING: THERMOPLASTIC, UL 94V-0 RATED. COLOR IN BLACK.
CONTACT: COPPER ALLOY
SHELL: COPPER ALLOY.
- FINISH:
CONTACT: UNDERPLATED 50u" MIN. NICKEL, OVER ALL;
100u" MIN. PURE MATTE TIN PLATED IN SOLDERING AREA;
30u" MIN. GOLD PLATING ON CONTACT AREA.
SHIELD: NICKEL 80u" MIN. PLATED OVER ALL.
- THE HOUSING WILL WITHSTAND EXPOSURE TO 260 DEGREE C PEAK TEMPERATURE FOR 10 SECONDS IN A IR REFLOW APPLICATION. AND THIS PRODCUT MEETS EUROPEAN UNION DIRECTIVES AND OTHER COUNTRY REGULATIONS AS DESCRIBED IN GS-22-008.
- PRODUCT SPECIFICATION: GS-12-174; PACKAGING SPECIFICATION: GS-14-873.
- PRODUCT ORDERING DATA :

FOR LEAD-FREE

10119313 - X X X X X LF

- LF: LEAD FREE PLATING
- SHELL MATERIAL:
BLANK: BRASS
1: PHOSPHOR BRONZE
- PACKAGING METHOD:
T: TRAY PACKAGING STYLE.
R: TAPE AND REEL PACKAGING STYLE.
C: TAPE AND REEL WITH CAP
- SHELL PEG OPTION:
1: DIP TYPE, SEE PAGE 1
2: SMT TYPE, SEE PAGE 2
- HSG MATERIAL:
0: LCP
- PLATING IN CONTACT AREA:
3: 30u" MIN. Au.

3	SHELL	1	COPPER ALLOY	SEE NOTE 2
2	TERMINAL	5	COPPER ALLOY	SEE NOTE 2
1	HOUSING	1	THERMOPLASTIC	COLOR: BLACK
ITEM	NAMES	QT'Y	MATERIAL	FINISH

mat'l. code		surface	tolerance	projection	product family
		ISO 1302 ✓	ISO 406 ISO 1101		HPL 511
ltr	ecn no	dr	date	tolerances unless otherwise specified	title
A	-	A.ZH	05/03/12	angles	MINI USB 5PF VERTICAL TYPE
B	ELX-N-16102	J.H	10/21/13.	linear	MINI USB B RECEPTACLE
C	ELX-N-17159	LQ	3/10/14	0±2'	scale 1:1
D	ELX-N-22660	LQ	12/01/15	dr	Yuan-Yuan Bao 2020/12/23
E	ELX-N-30880	LZ	08/02/18	eng	Yuan-Yuan Bao 2020/12/23
F	ELX-N-39429-I	YY	12/23/20	chr	LQ Lei 2020/12/23
		appd	Tim Yao	2020/12/23	
sheet	revision	F			
index	sheet	1/2			



Amphenol FCI

© 2016 AFCI

PRODUCT NO.
10119313-*

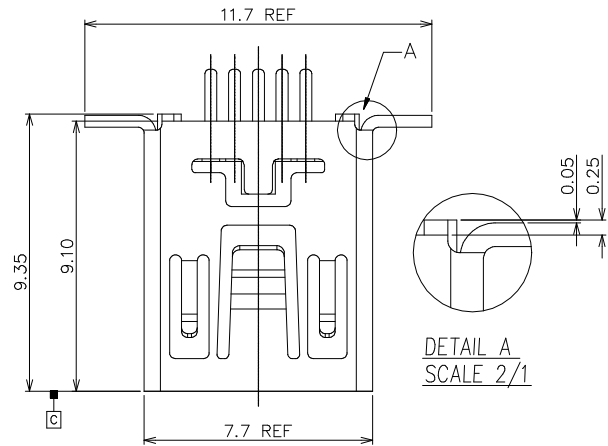

DETAIL A
SCALE 2/1

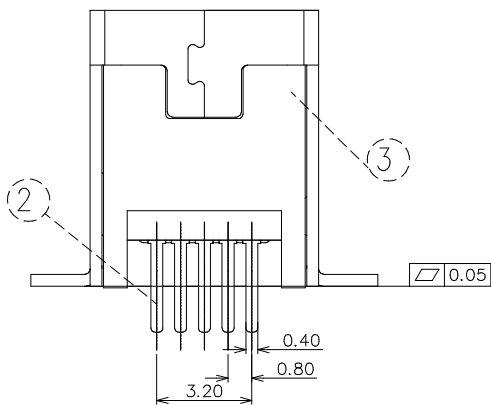
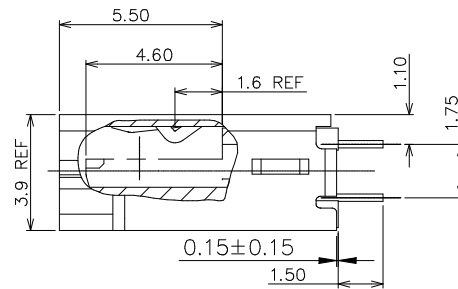
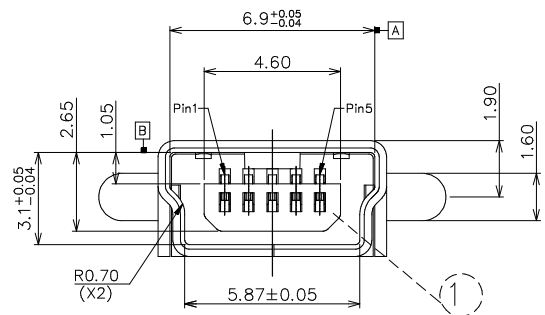
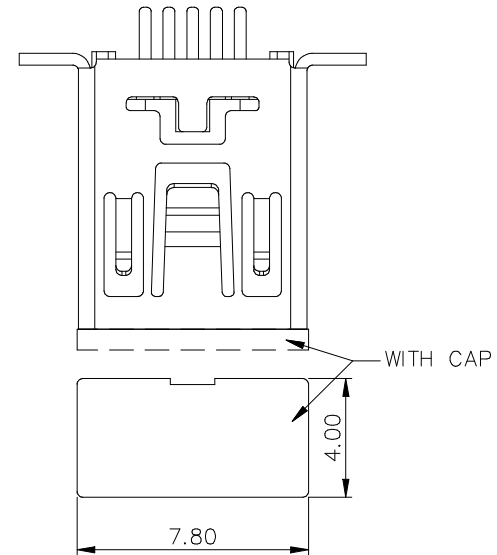
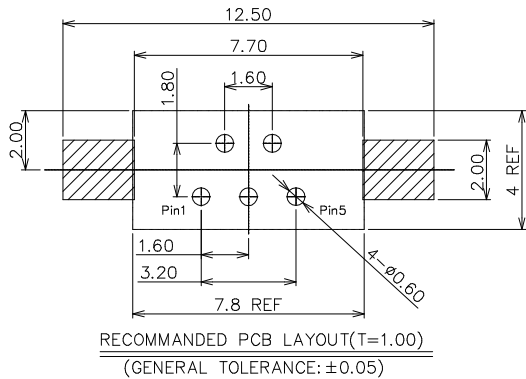

PLEASE SEE PAGE ONE FOR THE NOTES

mat'l. code		surface E4	tolerance	projection	product family
ISO 1302		ISO 406	ISO 1101	HPL 511	
ltr	ecn no	dr	date	tolerances unless otherwise specified	title
F				linear	MINI USB 5PF VERTICAL TYPE
				angles	MINI USB B RECEPTACLE
				0°±2'	scale 1:1
				dr	Y-Y Bao 2020/12/23
				engr	Y-Y Bao 2020/12/23
				chr	LQ Lei 2020/12/23
				appd	Tim Yao 2020/12/23
sheet index	revision	F			
	sheet	2/2			
				Amphenol FCI	dwg no
					10119313
					sheet 2 of 2
					size A3
					type Product Customer Drawing